



Controller/Preamplifier/Tube Preamplifier



C500 Owner's Manual

The lightning flash with arrowhead, within an equilateral triangle, is intended to alert the user to the presence of uninsulated “dangerous voltage” within the product’s enclosure that may be of sufficient magnitude to constitute a risk of electric shock to persons.



AVIS RISQUE DE CHOC ELECTRIQUE - NE PAS OUVRIR.

The exclamation point within an equilateral triangle is intended to alert the user to the presence of important operating and maintenance (servicing) instructions in the literature accompanying the appliance.

WARNING - TO REDUCE RISK OF FIRE OR ELECTRICAL SHOCK, DO NOT EXPOSE THIS EQUIPMENT TO RAIN OR MOISTURE.

NO USER-SERVICEABLE PARTS INSIDE. REFER SERVICING TO QUALIFIED PERSONNEL.

To prevent the risk of electric shock, do not remove cover or back. No user-serviceable parts inside.

IMPORTANT SAFETY INSTRUCTIONS!

PLEASE READ THEM BEFORE OPERATING THIS EQUIPMENT.

1. Read these instructions.
2. Keep these instructions.
3. Heed all warnings.
4. Follow all instructions.
5. Do not use this apparatus near water.
6. Clean only with a dry cloth.
7. Do not block any ventilation openings. Install in accordance with the manufacturer’s instructions.
8. Do not install near any heat sources such as radiators, heat registers, stoves, or other apparatus (including amplifiers) that produce heat.
9. Do not defeat the safety purpose of the polarized or grounding-type plug. A polarized plug has two blades with one wider than the other. A grounding type plug has two blades and a third grounding prong. The wide blade or the third prong are provided for your safety. If the provided plug does not fit into your outlet, consult an electrician for replacement of the obsolete outlet.
10. Protect the power cord from being walked on or pinched particularly at plugs, convenience receptacles, and the point where they exit from the apparatus.
11. Only use attachments/accessories specified by the manufacturer.
12. Use only with the cart, stand, tripod, bracket, or table specified by the manufacturer, or sold with the apparatus. When a cart is used, use caution when moving the cart/apparatus combination to avoid injury from tip-over. 
13. Unplug this apparatus during lightning storms or when unused for long periods of time.
14. Refer all servicing to qualified service personnel. Servicing is required when the apparatus has been damaged in any way, such as power-supply cord or plug is damaged, liquid has been spilled or objects have fallen into the apparatus, the apparatus has been exposed to rain or moisture, does not operate normally, or has been dropped.
15. Do not expose this equipment to dripping or splashing and ensure that no objects filled with liquids, such as vases, are placed on the equipment.
16. To completely disconnect this equipment from the a.c. mains, disconnect the power supply cord plug from the a.c. receptacle.
17. The mains plug of the power supply cord shall remain readily operable.
18. Do not expose batteries to excessive heat such as sunshine, fire or the like.

Thank You

Your decision to own this McIntosh C500 Controller together with the Preamplifier or Tube Preamplifier ranks you at the very top among discriminating music listeners. You now have “The Best.” The McIntosh dedication to “Quality,” is assurance that you will receive many years of musical enjoyment from this unit.

Please take a short time to read the information in this manual. We want you to be as familiar as possible with all the features and functions of your new McIntosh.

Please Take A Moment

The serial number, purchase date and McIntosh Dealer name are important to you for possible insurance claim or future service. The spaces below have been provided for you to record that information:

Dealer Name	Purchase Date	Model Number	Serial Number

Technical Assistance

If at any time you have questions about your McIntosh product, contact your McIntosh Dealer who is familiar with your McIntosh equipment and any other brands that may be part of your system. If you or your Dealer wish additional help concerning a suspected problem, you can receive technical assistance for all McIntosh products at:

McIntosh Laboratory, Inc.
2 Chambers Street
Binghamton, New York 13903
Phone: 607-723-1545
Fax: 607-724-0549

Customer Service

If it is determined that your McIntosh product is in need of repair, you can return it to your Dealer. You can also return it to the McIntosh Laboratory Service Department. For assistance on factory repair return procedure, contact the McIntosh Service Department at:

McIntosh Laboratory, Inc.
2 Chambers Street
Binghamton, New York 13903
Phone: 607-723-3515
Fax: 607-723-1917

Table of Contents

Safety Instructions	2
Thank You and Please Take a Moment	3
Technical Assistance and Customer Service	3
Table of Contents	3
Important Information and Connector Information	4
Introduction	4
Performance Features	5
Dimensions	6-8
Installation	9

Connections:

C500 Rear Panels	11
C500 Controller Rear Panel Connections (Separate Sheet)	Mc1A
C500 Preamplifier and Tube Preamplifier Rear Panel Connections (Separate Sheet)	Mc2A
How to Connect the C500 Controller and Preamplifier and Pasthru Mode	12-13
Connection Diagrams (Separate Sheet)	Mc3A, Mc3B
Connection Diagrams (Separate Sheet)	Mc1B

Front Panel Features:

C500 Controller Front Panel Controls, Displays and Push-buttons	14
C500 Preamplifier and C500 Tube Preamplifier Front Panel Displays and Jack	15

Setup:

How to Operate the Setup Modes	16-25
--------------------------------------	-------

Remote Control:

Remote Control Push-buttons	26
How to operate the Remote Control	27

Operation:

How to Operate the C500	28-32
-------------------------------	-------

Additional Information:

Technical Description	33-36
Block Diagrams (Separate Sheet)	Mc2B
Specifications	37-38
Packing Instruction	39



Important Information

WARNING: The McIntosh C500 is a two chassis design, with separate Preamplifier and Controller chassis. There are custom interconnecting cables and custom chassis sockets used to connect the two chassis together.

Use **ONLY** the custom interconnect cables supplied with the C500 to connect the chassis together.

DO NOT connect the C500 Left and Right 25-Pin Chassis Sockets to any other component. Failure to observe the above warnings will result in damage to the components connected.

1. The C500 System consists of two separate chassis, one Controller and one Preamplifier. The C500 Controller Chassis will be referred to as the C500C throughout this Owner's Manual. In a similar manner, the C500 Preamplifier (Solid State) Chassis will be referred to as the C500P and the C500 Tube Preamplifier Chassis will be referred to as the C500T throughout this Owner's Manual.
2. For additional information on Audio Connections, refer to the Owner's Manual(s) for the component(s).
3. Connecting Cables and Connectors are available from the McIntosh Parts Department:
 - Data, Power Control and Trigger Cable Part No. 170-202**
Six foot, shielded 2 conductor, with 1/8 inch stereo mini phone plug on each end.
 - Controller to Preamplifier Cable Part No. 171-872**
Three foot, shielded 23 conductor, male-to-female custom cable, two required between Controller and Preamplifier. Do not use any other cable when connecting the C500 Controller to the C500 Preamplifier or C500 Tube Preamplifier. This cable is for use only with the C500 Controller and Preamplifier.
4. The Main AC Power Cable going to the C500C and any other McIntosh Component(s) should not be connected to an AC Power Outlet until all the system components are connected together. When the C500C and other McIntosh Components are in their Standby Power Off Mode, the Microprocessor's Circuitry inside each component is active and communication is occurring between them. Failure to do so could result in malfunctioning of some or all of the system's normal operations.
5. Up to two sensors can be wired in parallel for Remote Control of the C500 from other rooms.
6. Balanced and Unbalanced Inputs and Outputs can be mixed. For example, you may connect signal sources to Unbalanced Inputs and send signals from the Balanced Outputs. You can also use Balanced and Unbalanced outputs simultaneously, connected to different power amplifiers.
7. Sound Intensity is measured in units called Decibels and "dB" is the abbreviation.

8. If the C500P and/or C500T Preamplifiers 23-conductor custom interconnect cable(s) becomes temporarily disconnected from the C500C when it is On or in Stand-by Mode, a cable error message will appear on the C500C. Remove the AC Power Cord from the C500C, connect the disconnected 23-conductor custom interconnect cable(s) and then reconnect the AC Power Cord. The C500 System will automatically reset itself to the previous configuration.

Connector Information

XLR Connectors

Below is the Pin configuration for the XLR Balanced Input and Output Connectors on the C500 Preamplifier. Refer to the diagram for connection:

- PIN 1: Shield/Ground
- PIN 2: + Signal
- PIN 3: - Signal

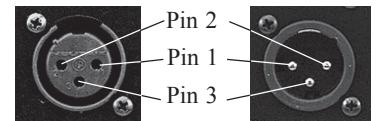

Main Power Control Connectors

The C500's Power Control Outputs provide a +5 volt signal. An additional connection is for controlling the illumination of a Power Amplifier Output Meter. Use a 1/8 inch stereo mini phone plug to connect to the Power Control Input on other McIntosh Components.

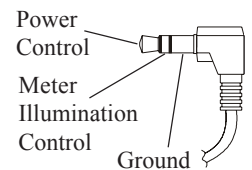

Trigger Control Connectors

The C500's Trigger Control Outputs provide either a +5 volt (default) or +12 volt signal (refer to page 18). Use a 1/8 inch stereo mini phone plug to connect to the Power Control Input on McIntosh and/or non-McIntosh components.

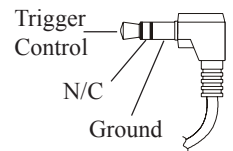

Data and IR Port Connectors

The C500's Data Port Output provides Remote Control Signals. Use a 1/8 inch stereo mini phone plug to connect to the Data Port Inputs on McIntosh Source Units.

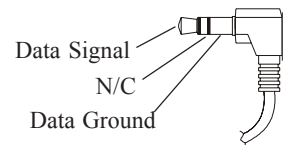

Introduction

The C500 Preamplifier with a Controller is one of the finest audio preamplifiers McIntosh has ever created. No design compromises were allowed in the quest for a preamplifier, both Solid State and Tube with absolute accuracy, total sonic purity and virtual elimination of distortion and audible noise. For those who have been searching for the "Best in Preamplifiers", your wait is over.

Performance Features

- **Dual Chassis with Dual Mono Design**

The Dual Chassis design completely separates all power supply, microprocessor and control circuits from the pure audio circuits for total noise isolation. To further aid in channel isolation the circuitry for both channels is totally separate, physically isolated and shielded. The C500 incorporates two identical power supplies one for each channel, to help assure total channel isolation.

- **Balanced and Unbalanced Inputs/Outputs**

Four balanced high level inputs and three balanced main outputs are provided. Four high level unbalanced inputs, two unbalanced outputs as well as listen and record processor loops are included.

- **Moving Coil and Moving Magnet Phono Inputs**

The C500 contains two different shielded precision Phono Preamplifier Circuits. One is designed for low output Moving Coil Phono Cartridges and has selectable resistance loading. The second Phono Preamplifier is for Moving Magnet Cartridges and has selectable capacitive loading. Both circuits use the latest designs to provide the lowest possible noise and distortion. The RIAA Correction Equalization Circuitry utilizes 0.5% tolerance resistors and 1% capacitors for an extremely flat frequency response.

- **Input Level Trim Adjustment**

All the C500 Inputs can be matched in volume level, so there are no abrupt changes in volume levels between the different inputs.

- **Precision Tracking Variable Rate Volume Control**

Volume levels are controlled by a Multi-Stage Precision Digitally Controlled Attenuator System with an Optical Encoder Rotary Control. This helps to assure a tracking accuracy between channels of 0.1dB, while providing 213 individual 0.5dB steps of change in the volume level and all of this with no noise as the volume level is changed.

- **Balance Control**

The Balance Control Circuitry allows for precise and repeatable change in channel balance in 1dB steps.

- **Alphanumeric Fluorescent Display**

The Multifunction Front Panel Display indicates the Listen and Record Source Selection, with Volume indicated in dB or percentage and Balance Levels in dB. Setup Mode Selections and Adjustments are also displayed.

- **Precision Parts**

All resistors are precision metal film type. Low dielectric absorption film capacitors are used in all critical circuit locations.

- **Passthru Mode**

The Automatic Passthru Mode allows the C500 to become part of a Multichannel Sound System for DVD-Audio, SACD and Home Theater Movies.

- **Remote Control**

The Remote Control included with the C500 allows remote operation of the Preamplifier along with controlling various other McIntosh Source Components and Processors.

- **Optional External Sensor Input**

There are provisions for connecting external sensors, which allow for enjoying your McIntosh System from another room(s) in your home via the remote control.

- **Power Control Output**

A Power Control connection for convenient turn-on of McIntosh Source Components, McIntosh Power Amplifiers and accessories is included.

- **Glass Front Panel with Fiber Optic Illumination**

The famous McIntosh Illuminated Glass Front Panel ensures the pristine beauty of the C500 will be retained for many years. The Illumination of the Front Panel is accomplished by the combination of custom designed Fiber Optic Light Diffusers and Light Emitting Diodes (LEDs). This provides even Front Panel Illumination, together with the extra long life LEDs.

- **Extruded Side Panels**

The sides of the VP1000 are extruded aluminum panels with a bead blast textured surface and a black anodized finish.

- **Special Power Supply**

Fully regulated Power Supplies, one for each channel, utilize special R-Core Power Transformers helping to ensure stable noise free operation even though the power line varies.



Dimensions

The following dimensions can assist in determining the best location for the C500 Controller, C500 Preamplifier and C500 Tube Preamplifier. There is additional information on page 8 pertaining to installing the C500 System into cabinets.

Front View of the C500C

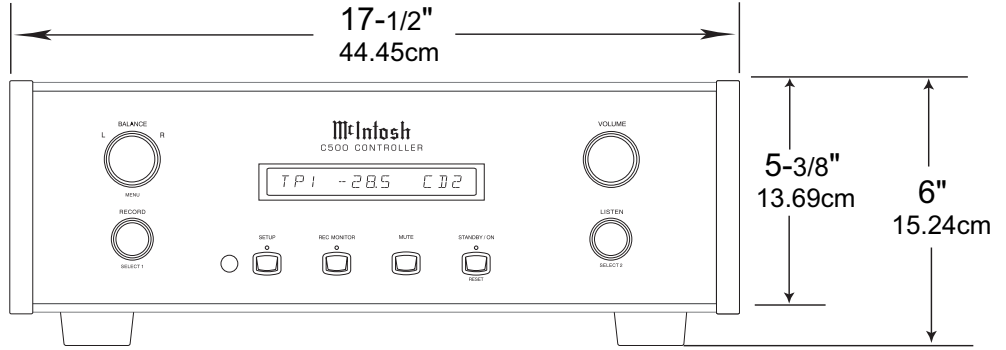

Rear View of the C500C

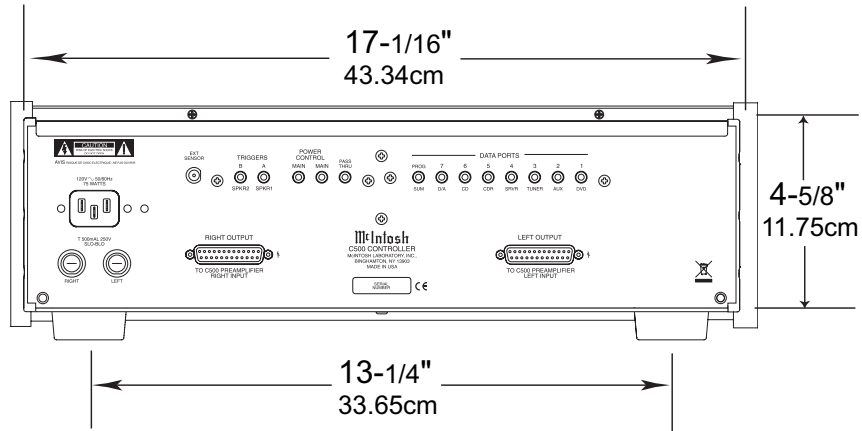

Side View of the C500C

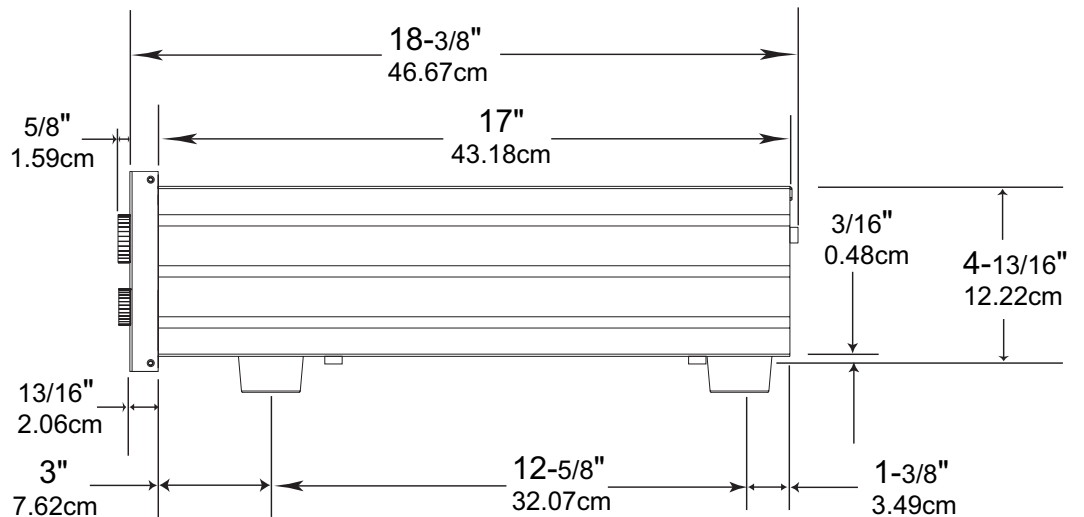

Front View of the C500P

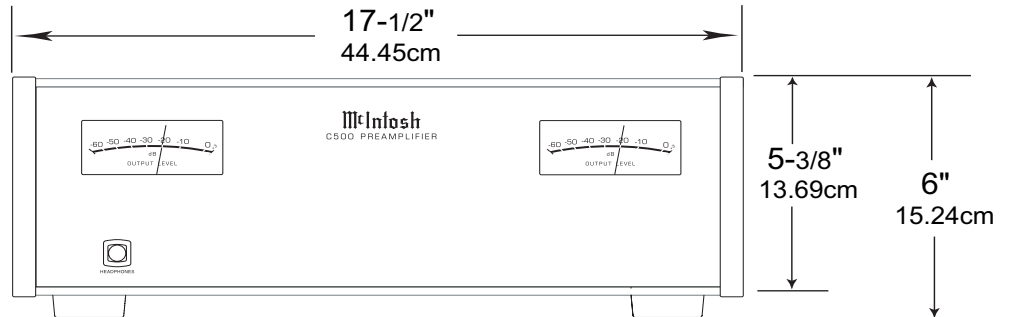

Rear View of the C500P

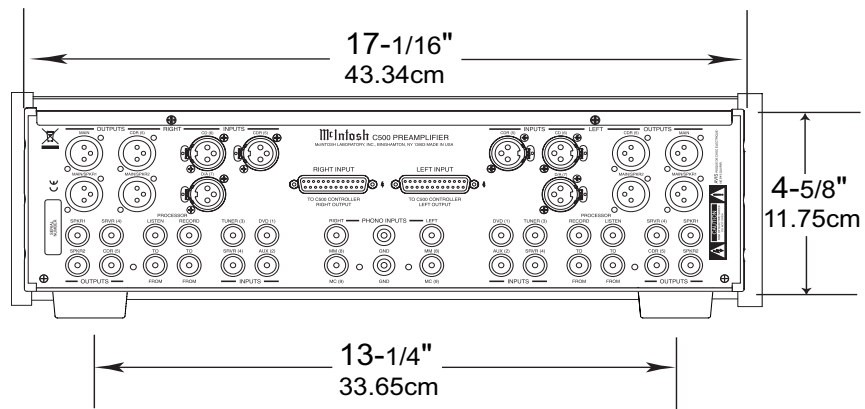

Side View of the C500P

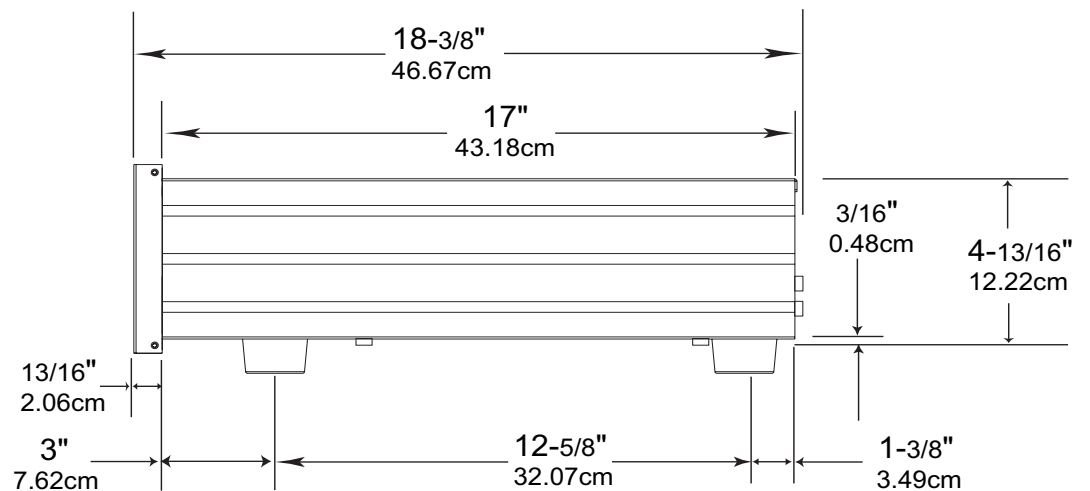

Front View of the C500T

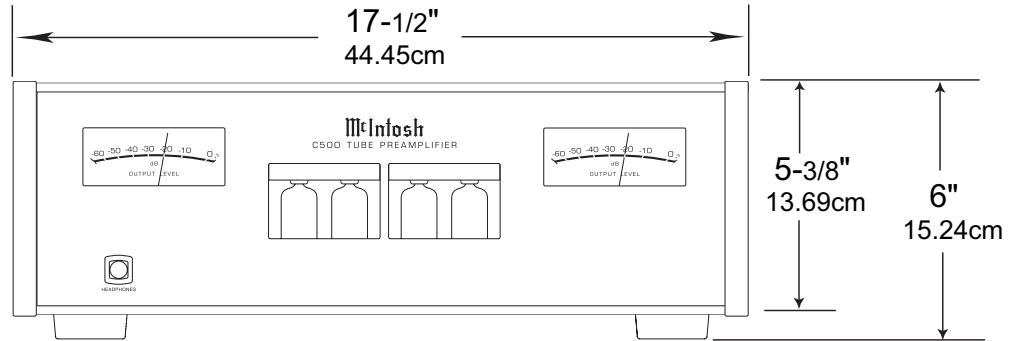

Rear View of the C500T

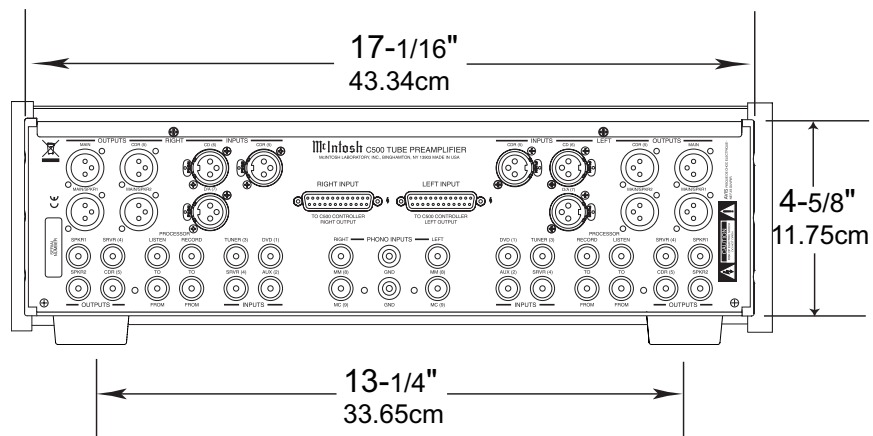

Side View of the C500T

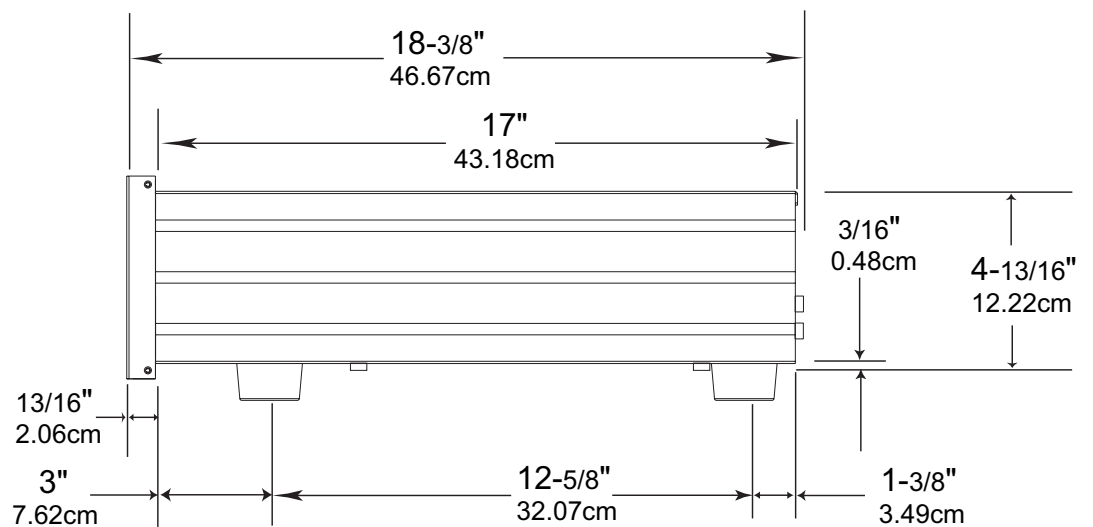

Installation

The C500C, C500P and C500T can be placed upright on a table or shelf, standing on their four feet. The four feet, may be removed from the bottom of the C500C, C500P and C500T when they are custom installed as outlined below. The four feet, together with the mounting screws should be retained for possible future use if the C500C, C500P and C500T are removed from the custom installation and used free standing. They also can be custom installed in a piece of furniture or cabinet of your choice. The required panel cutout, ventilation cutout and unit dimensions are shown.

Always provide adequate ventilation for the C500C, C500P and C500T. Cool operation ensures the longest possible operating life for any electronic instrument. Do not install the units directly above a heat generating component such as a high powered amplifier. If all the components are installed in a single cabinet, a quiet running ventilation fan can be a definite asset in maintaining all the system components at the coolest possible operating temperature.

A custom cabinet installation should provide the following minimum spacing dimensions for cool operation refer to the illustration. Allow at least 2 inches (5.08 cm) above the top of the C500C, C500P and C500T, 2 inches (5.08cm) below the bottom and 1 inch (2.54 cm) on each side of the Controller/Preamplifier, so that airflow is not obstructed. Allow 24 inches (61.0cm) depth behind the front panel¹ for Interconnect Cables. Allow 1 inch (2.54 cm) in front of the

mounting panel for clearance. When the C500C, C500P and C500T are to be installed in cabinets refer to the illustration below. Be sure to cut out a ventilation hole in the mounting shelf according to the dimensions in the drawing.

¹ Interconnect Cables are supplied with the C500P and C500T Preamplifiers and connect to the C500 Controller.

**C500C
C500P
C500T
Front Panel
Cabinet Cutout**

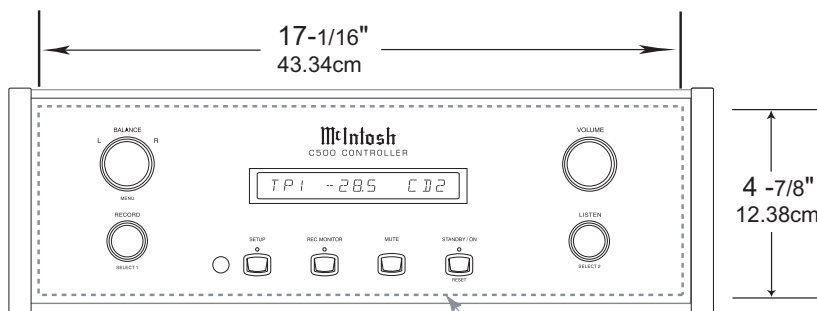

**C500C
C500P
C500T
Side View in a
Partially Open
Cabinet**

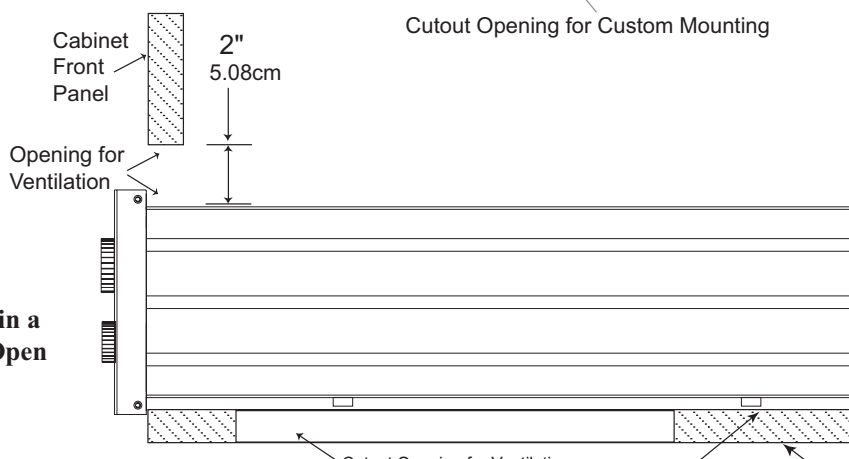

**C500C
C500P
C500T
Support Shelf
in Cabinet**

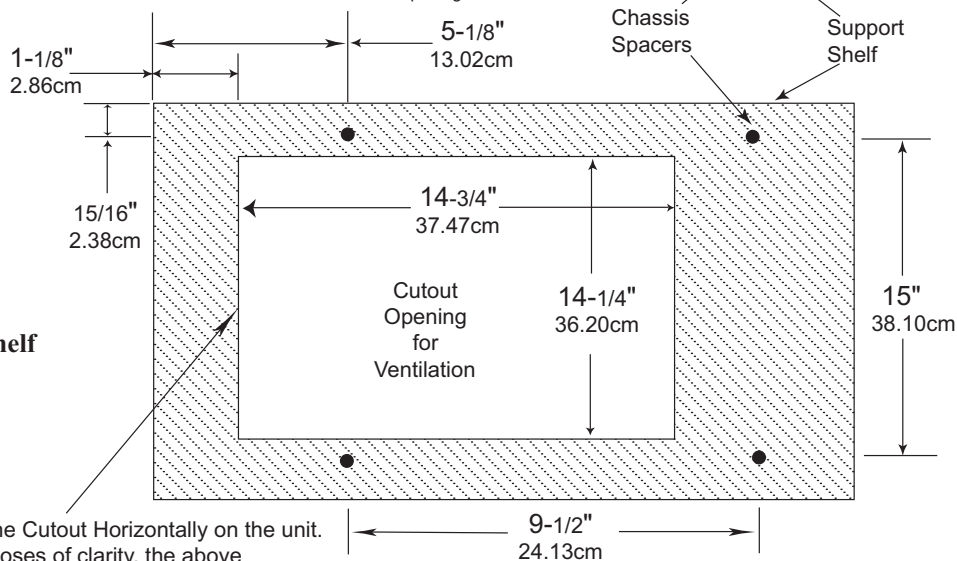

Notes: Center the Cutout Horizontally on the unit.
For purposes of clarity, the above illustration is not drawn to scale.

Rear Panel Connections

The identification of Rear Panel Connections for the C500 Controller, C500 Preamplifier and C500 Tube Preamplifier are located on separate folded sheets contained in the Owner’s Manual Packet.

C500 Controller

Refer to folded sheet “Mc1A”
C500 Controller Rear Panel
Connections

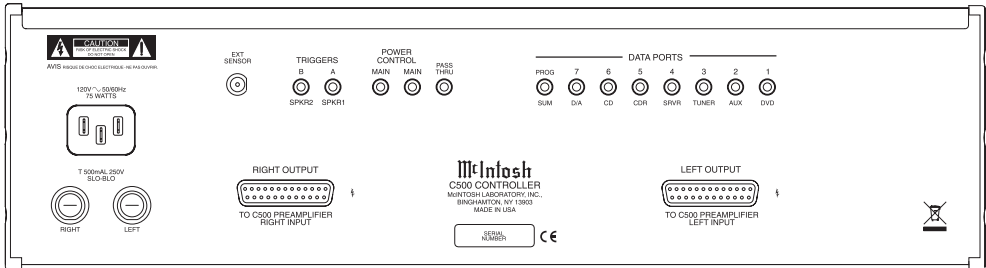

C500 Preamplifier

Refer to folded sheet “Mc2A”
C500 Preamplifier Rear Panel
Connections

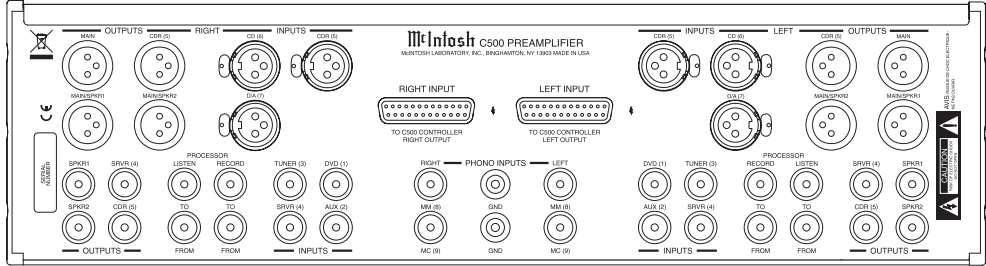

C500 Tube Preamplifier

Refer to folded sheet “Mc2A”
C500 Tube Preamplifier Rear
Panel Connections

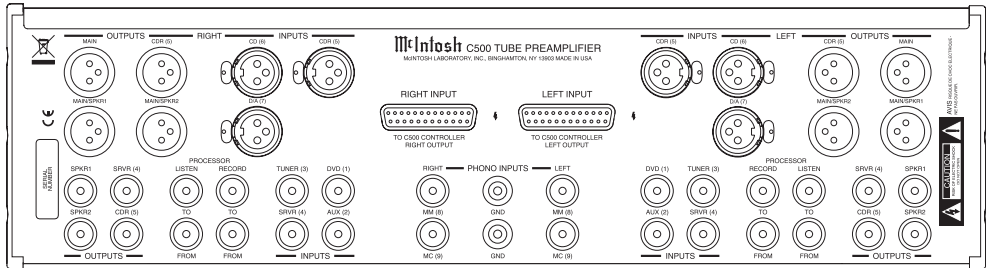



How to connect the C500

This page contains information for connecting the McIntosh C500C to the C500P or C500T and to other audio components.

The C500 has the ability to automatically switch power On/Off to McIntosh Source Components via the Power Control Connections. The Data Port Connections allow for the remote operation of basic functions using the C500 Remote Control. With an external sensor connected to the C500, remote control operation of the system is possible from another room and/or when the C500 is located in a cabinet with the doors closed.

The connection instructions below, together with the Input and Output Connection Diagrams located on the separate folded sheet “**Mc3A/3B**”, are an example of a typical audio system. Your system may vary from this, however the actual components would be connected in a similar manner.

For additional information refer to “Connector and Cable Information” on page 4.

Note: Balanced and Unbalanced Inputs and Outputs can be mixed. For example, you may connect signal sources to Unbalanced Inputs and send signals out from the Balanced Outputs. You can also use Balanced and Unbalanced outputs simultaneously, connected to different power amplifiers.

Power Control Connections:

1. Connect one of the supplied custom 23-Conductor Cables from the C500C RIGHT OUTPUT Socket to the C500P or C500T RIGHT INPUT Socket.
Note: After the cable connector is firmly seated into the chassis socket, rotate the two locking screws on either side until they are finger tight.
2. In a similar manner, connect the other 23-Conductor Cable from the C500C LEFT OUTPUT Socket to the LEFT INPUT Socket on the Preamplifier.
3. Connect a Cable from the C500C POWER CONTROL MAIN Jack to the Power Control In Jack on the McIntosh Left Channel Power Amplifier and another Control Cable from the McIntosh Left Channel Power Amplifier Power Control Out Jack to the McIntosh Right Channel Power Amplifier Power Control In Jack.
Note: There is approximately a one-half second delay added to the Power Control Out Jack signal going to the next McIntosh Power Amplifier, to reduce the strain on the AC Power Line.
4. Connect a Cable from the other C500C POWER CONTROL MAIN Jack to the Power Control In of the McIntosh D/A Converter.
5. Connect a Cable from the McIntosh D/A Converter Power Control Out Jack to the Power Control In of a

McIntosh AM/FM Tuner.

6. Connect a Cable from the McIntosh AM/FM Tuner Control Out Jack to the Power Control In of a McIntosh Audio/Video Player.
7. Connect any remaining McIntosh Source Components in a similar manner.

Data Control Connections:

8. Connect a Cable from the C500C D/A (7) DATA PORT to the Data In Jack of the McIntosh MDA1000 D/A Converter.
Note: If a McIntosh MCD1000 is part of the system, connect the SUM DATA PORT Jack to the Data Port In Jack on the MCD1000, using a Data Cable. Refer to figure A.
9. Connect a Cable from the C500C TUNER (3) DATA PORT to the Data In Jack of the McIntosh Tuner.
10. Connect a Cable from the C500C DVD (1) DATA PORT to the Data In Jack of the McIntosh Audio/Video Player.
11. Connect any remaining McIntosh Source Components in a similar manner.
12. Optionally connect a RG-59 or RG-6 Cable from the C500C Rear Panel EXT Sensor connector to the McIntosh Sensor.

Audio Connections:

13. Connect XLR Cables from the McIntosh D/A Converter to the C500 Preamplifier Balanced XLR D/A (7) LEFT and RIGHT INPUTS.
14. Connect Cables from the McIntosh Tuner Fixed Audio Outputs to the C500 Preamplifier Unbalanced TUNER (3) LEFT and RIGHT INPUTS.
15. Connect Cables from the McIntosh Audio/Video Player 2CH Unbalanced Audio Outputs to the C500 Preamplifier Unbalanced DVD (1) LEFT and RIGHT INPUTS.
Note: The 2CH Balanced Audio Outputs of the McIntosh Audio/Video Player may be connected to the C500 Preamplifier CD (6) INPUTS instead of the Unbalanced Connections.
16. Connect Cables from the Turntable (with a Moving Magnet Cartridge) to the C500 Preamplifier Unbalanced MM (8) LEFT and RIGHT INPUTS.
Note: If the Turntable has a Moving Coil Cartridge, connect the cables to the MC (9) Inputs.
17. Connect the Turntable Ground Cable to the GND binding post located between the C500 Preamplifier MM (8) LEFT and RIGHT INPUTS.
18. Connect Cables from the External Sound Processor Left and Right Inputs to the C500 Preamplifier PROCESSOR TO LEFT and RIGHT Output Jacks.

19. Connect Cables from the External Sound Processor Left and Right Outputs to the C500 Preamplifier PROCES-
SOR FROM LEFT and RIGHT Input Jacks.
20. Connect Cables from the Music Server Left and Right
Outputs to the C500 Preamplifier Unbalanced SRVR
(4) LEFT and RIGHT INPUTS Jacks.
21. Connect Cables from the Music Server Left and Right
Inputs to the C500 Preamplifier Unbalanced SRVR (4)
LEFT and RIGHT OUTPUTS Jacks.
22. Connect XLR Cables from the C500 Preamplifier
MAIN LEFT and RIGHT Balanced OUTPUTS, to one
of the Balanced Inputs on the Left and Right McIntosh
Power Amplifiers.

Note: If the C500 is not part of a Multichannel Audio System, proceed to step 25.

Passthru Connections:

The C500 Preamplifier has a special operating mode known as Passthru, when it is used as part of a McIntosh Multi-channel Sound System. The Front Left and Right Channels coming from the McIntosh A/V Control Center connect to a predetermined input at a preset volume level and then onto the Left and Right Main Power Amplifiers/Loudspeakers. Passthru requires several extra connections and activation by using the SETUP Mode of the C500.

The following connection instructions, together with the Input and Output Connection Diagrams located on the separate folded sheet “Mc1B”, are an example of a typical audio system. Your system may vary from this, however the actual components would be connected in a similar manner. For additional information refer to “Connector and Cable Information” on page 4.

23. Connect a Power Control Cable from the McIntosh A/V Control Center Zone A Power Control Output Jack to the C500C PASSTHRU Input Jack.

Note: The Passthru Mode will also work non-McIntosh Multichannel Processors, the voltage required to activate the Passthru feature is +5 to +12 Volts D.C.

24. Connect XLR Cables from the McIntosh A/V Control Center Zone A Outputs Front Left and Right to the C500P CDR (5) LEFT and RIGHT INPUT Balanced Connectors.

Note: Any of the C500C Inputs (except for the MM (8), MC (9) and Record Link Inputs) both Balanced or Unbalanced may be used for the Passthru Mode.

A.C. Power Connections:

25. Connect the supplied AC Power Cord between the C500C AC Power Cord Socket and a live AC outlet. Refer to figure B.
26. Proceed to page 23 for customizing the SETUP Features of the C500 Preamplifier.

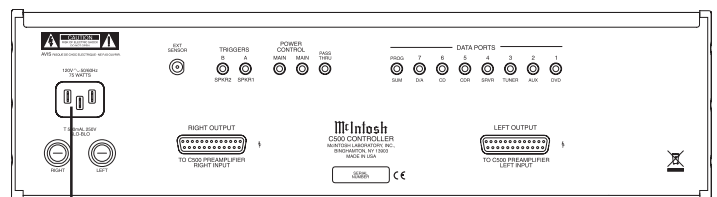

Figure B

Connect to a live AC Outlet

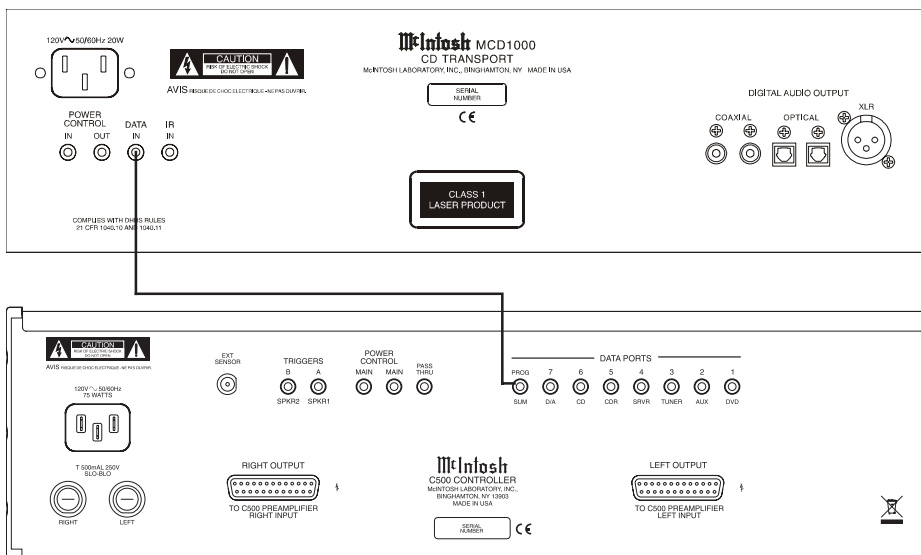
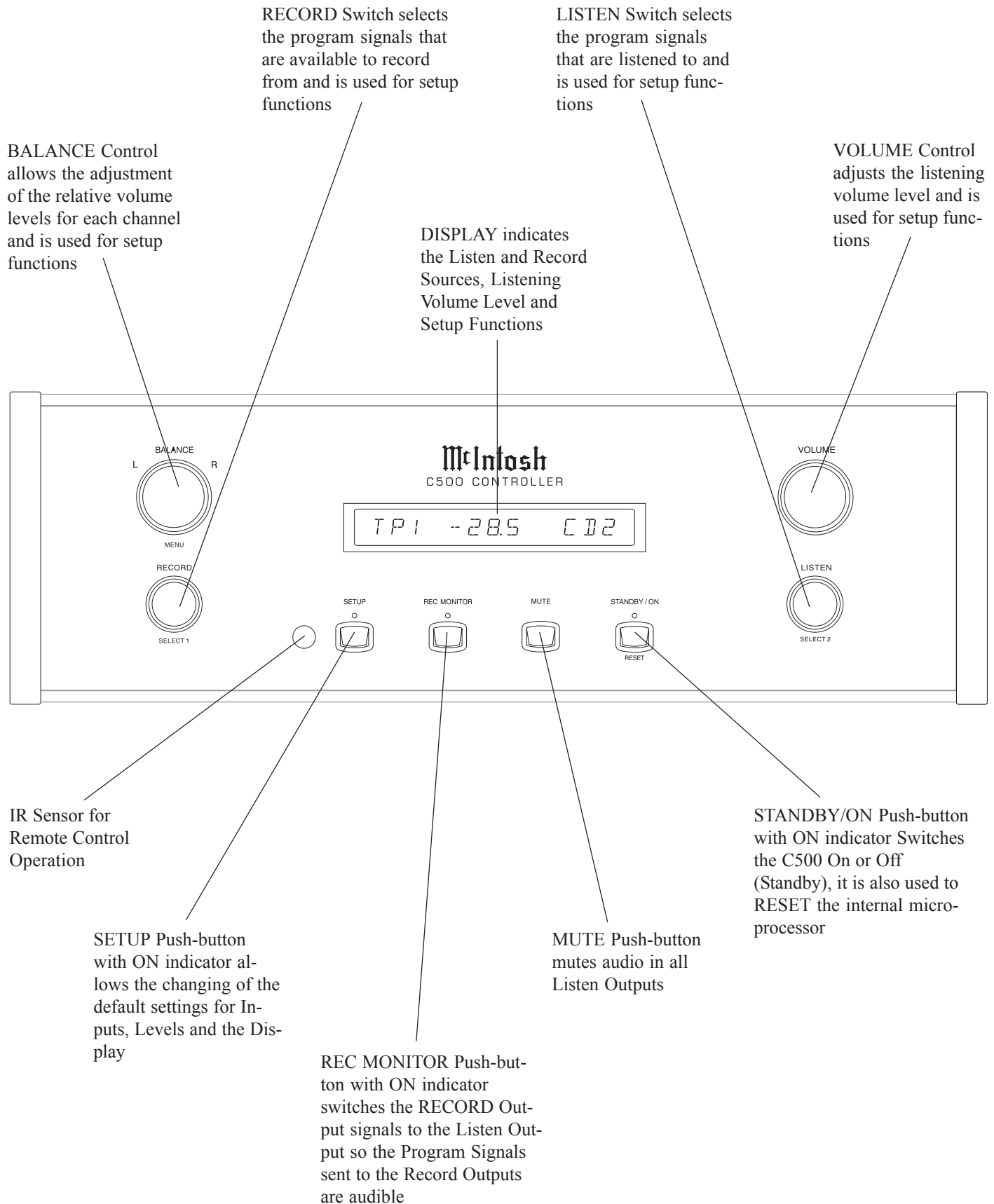

Figure A



C500 Controller Front Panel Controls, Displays, and Push-Buttons



C500 Preamplifier and C500 Tube Preamplifier Front Panel Displays and Jack

METER indicates the Preamplifier's Left Channel relative Output Level

METER indicates the Preamplifier's Right Channel relative Output Level

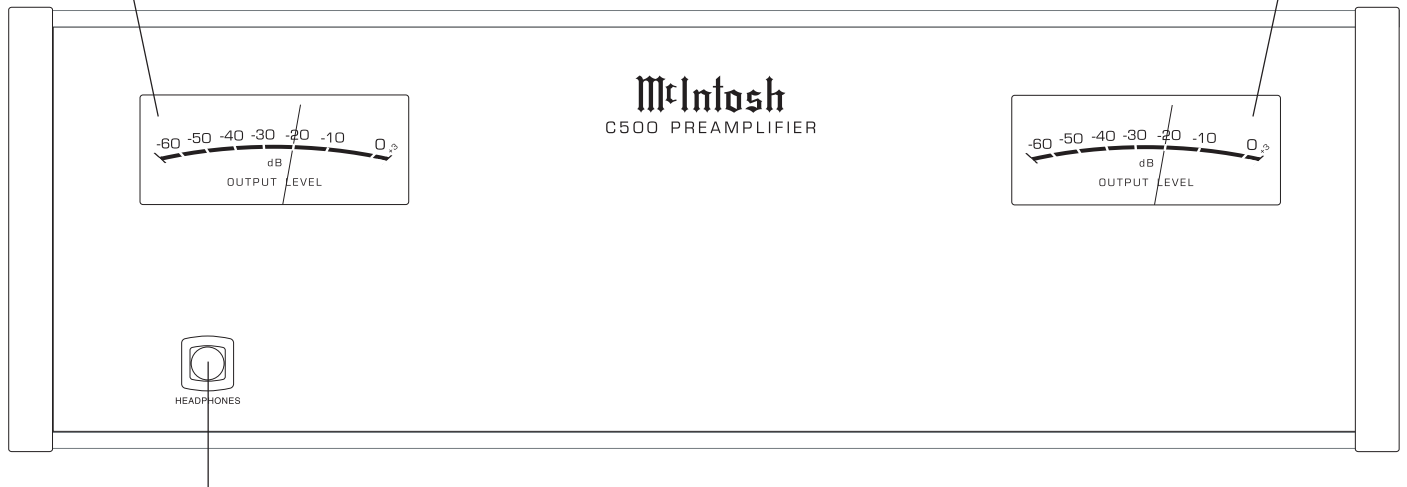

HEADPHONES jack accepts dynamic headphones

METER indicates the Preamplifier's Left Channel relative Output Level

METER indicates the Preamplifier's Right Channel relative Output Level

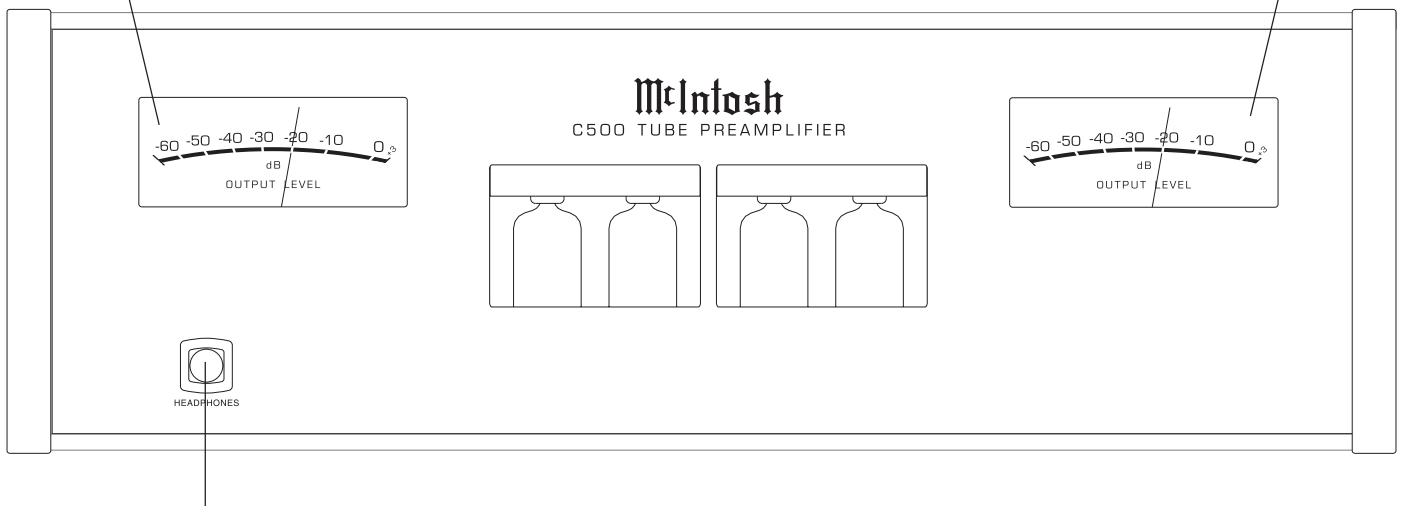

HEADPHONES jack accepts dynamic headphones



How to Operate the Setup Modes

Your McIntosh C500 has been factory configured for default operating settings that will allow immediately enjoyment of superb audio without the need for further adjustments. If you wish to make changes to the factory default settings, a Setup Feature is provided to customize the operating settings using the Front Panel Alphanumeric Display on the C500C Controller. The setup functions available for change and/or adjustments are dependent upon connection of the Preamplifier(s) C500P or C500T connected to the C500C Controller.

1. The Red LED above the STANDBY/ON push-button lights to indicate the C500 is in Standby mode and is connected to a live AC Outlet. To switch On the C500, press the STANDBY/ON push-button. Refer to figure 2. The Alphanumeric Display will indicate the last input listened to. If this is the first time the C500 is switched on, the display will indicate "15 TUNER", refer to figure 3.



Figure 3

Note: Dependent upon which Preamplifier (C500P or C500T) is connected to the C500C, the Front Panel Alphanumeric Display will indicate different operational messages when switched On, refer to page 28 for additional information. If the Front Panel Alphanumeric Display indicates CABLE ERROR, remove the AC Power Cord from the Rear Panel of the C500C. Refer to figure 4. Then check to verify that both interconnect cables coming from the C500P or C500T are connected to the correct sockets on the Rear Panel of the C500C. Refer to page 12. After correcting the cable connection error, reconnect the AC Power Cord to the Rear Panel of the C500C. Perform Step one again.



Figure 4

2. Press the C500C Front Panel SETUP push-button once. The LED above the SETUP Push-button will illuminate and the Front Panel Display will indicate CONTROLLER. The "Controller" is the first of the two main menus. The second main menu is named "Preamp" and will be accessed in step 5. Refer to figures 2 and 5.



Figure 5

3. Rotate the BALANCE (Menu) Control and notice that the Setup Controller Setup Mode advances through seven different possible adjustment selections and one informational display.

Note: When in SETUP MODE, it may be necessary to rotate the Controls BALANCE (Menu), RECORD (Select 1) and LISTEN (Select 2) either clockwise or counter-clockwise to the desired function or setting.

4. Press the SETUP Push-button to exit the CONTROLLER Menu, the LED above the SETUP Push-button will extinguish and the Front Panel Display will revert back to its normal display. Refer to figure 3.
5. Now Press the SETUP Push-button twice to enter the PREAMP Setup Menu. Refer to figure 6.



Figure 6

6. Rotate the BALANCE (Menu) Control and notice that the Setup Preamp Mode advances through nine different possible adjustment selections.

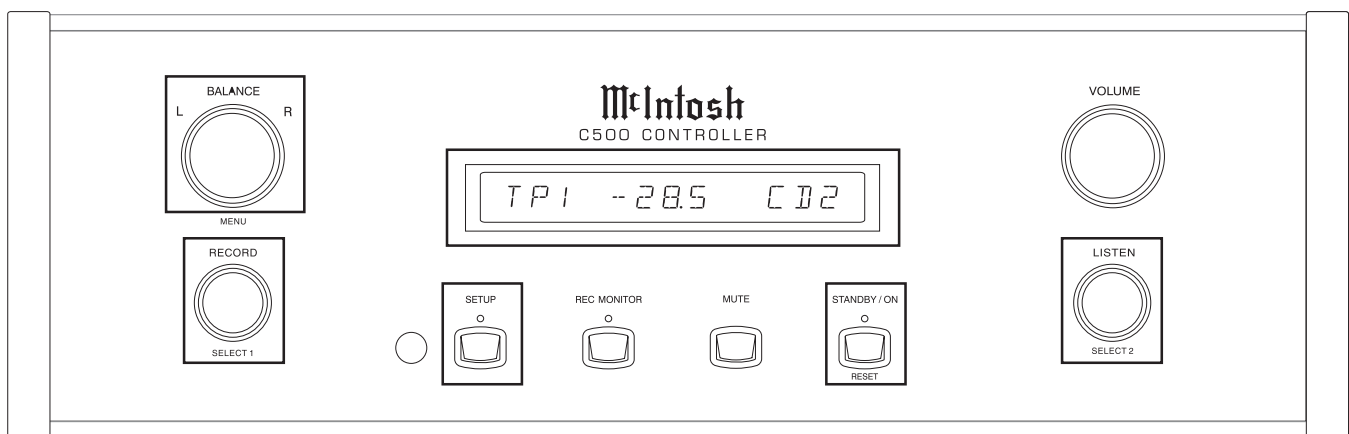

Figure 2

- To exit from the Setup Preamp Mode press the SETUP Push-button, the LED above the SETUP Push-button will extinguish and the Front Panel Display will revert back to its normal display. Refer to figure 3.

Default Settings

The following listings indicate the Setup Menu Mode (Controller or Preamp), Menu Name, Default Setting and the page number for instructions on how to change a setting.

<u>Menu</u>	<u>Function Name</u>	<u>Setting</u>	<u>Page No.</u>
Control	Version (C500 Firmware)	— . — —	17
Control	Display (Brightness)	7 — —	17
Control	Remote (Control)	HR061	17
Control	Meter (Illumination)	ON	18
Control	Volume (Display)	Percent	18
Control	Trigger A Lvl (Rear Panel Jack)	5V	18
Control	Trigger B Lvl (Rear Panel Jack)	5V	19
Control	Triamp (Balanced Outputs)	OFF	18
Control	D/A Ctrl (MDA1000)	OFF	19
Preamp	Input 3 (Title of Inputs)	TUN	20
Preamp	D Port (Assignment to Input)	Note 2	20
Preamp	Trim (Input Source Level)	0.0	21
Preamp	Trigger (Input Source)	--	22
Preamp	ACC Control (Remote Con.)	--	22
Preamp	LPROC (Listen Processor)	NONE	23
Preamp	RPROC (Record Processor)	NONE	23
Preamp	MM (Phono Capacitance)	50PF	24
Preamp	MC (Phono Resistance)	25 OHM	24
Preamp	Passthru (Multichannel)	OFF	24

Notes: 1. Charts on page 25 allow for recording any changes made to the default settings.

2. The D. Port default assignment is the same as the C500 Controller Rear Panel Data Port Labeling.

Firmware Version

The C500 functionality is controlled by internal software that is known as Firmware. The Version of the Firmware in the C500 can be identified at any time by utilizing the Setup Controller Mode.

- Press the SETUP Push-button once to access the Setup Controller Mode.
- Rotate the MENU Control until VERSION 1.0 or higher appears. Refer to figure 7.



Figure 7

- The number after the character V is the Firmware number.

- If no other adjustments are to be made at this time, press the SETUP Push-button to exit the Setup Controller Mode or proceed to the next desired Setup Controller Mode for adjustment.

Display Brightness

The Front Panel Alphanumeric DISPLAY Brightness may be varied from a setting of 1 (Dim) to 7 (Bright). Follow the steps below for reducing the Display Brightness.

- Press the SETUP Push-button once to access the Setup Controller Mode unless the C500C is already in the Setup Controller Mode.
- Rotate the MENU Control until the word “DISPLAY 7” appears. Refer to figure 8.



Figure 8

- Rotate the SELECT 2 Control until the Front Panel Alphanumeric Display indicates “DISPLAY 5” or the desired Brightness is achieved. Refer to figure 9.



Figure 9

- If no other adjustments are to be made at this time, press the SETUP Push-button to exit the Setup Controller Mode or proceed to the next desired Setup Controller Mode for adjustment.

Remote Control

The C500 Preamp default setting for remote control operation is for the supplied McIntosh HR061 Remote Control. The setting may be changed to allow the C500 to work with the legacy HR054 Remote Control by performing the following steps:

- Press the SETUP Push-button once to access the Setup Controller Mode unless the C500C is already in the Setup Controller Mode.
- Rotate the MENU Control until the words “REMOTE HR061” appears. Refer to figure 9A.



Figure 9A



3. Rotate the SELECT 2 Control counterclockwise until the Front Panel Alphanumeric Display indicates REMOTE HR054. Refer to figure 9B.



Figure 9B

4. If no other adjustments are to be made at this time, press the SETUP Push-button to exit the Setup Controller Mode or proceed to the next desired Setup Controller Mode for adjustment.

Meter Illumination

The Front Panel Meter Illumination of the C500P or C500T Preamplifiers may be switched Off. Follow the steps below:

1. Press the SETUP Push-button once to access the Setup Controller Mode unless the C500C is already in the Setup Controller Mode.
2. Rotate the MENU Control until the words “METER ON” appears. Refer to figure 10.
3. Rotate the SELECT 2 Control until the Front Panel Al-



Figure 10

phanumeric Display indicates “METER OFF”. Refer to figure 11.

4. If no other adjustments are to be made at this time,



Figure 11

press the SETUP Push-button to exit the Setup Controller Mode or proceed to the next desired Setup Controller Mode for adjustment.

Volume Display

The Front Panel Alphanumeric Display of the current volume setting may be indicated either as a Percentage of the maximum volume (0 - 100%) or in Decibels (-92.0dB to +15.0dB). To change the display to Decibels follow the steps below:

1. Press the SETUP Push-button once to access the Setup Controller Mode unless the C500C is already in the Setup Controller Mode.
2. Rotate the MENU Control until the words “VOL PERCENT” appears. Refer to figure 12.



Figure 12

3. Rotate the SELECT 2 Control until the Front Panel Alphanumeric Display indicates “VOL DECIBEL”. Refer to figure 13.



Figure 13

4. If no other adjustments are to be made at this time, press the SETUP Push-button to exit the Setup Controller Mode or proceed to the next desired Setup Controller Mode for adjustment.

Trigger A Voltage (Power Control)

The Rear Panel Trigger A Jack can provide either a 5 or 12 Volt Output when activated, with 5 Volts as the default. McIntosh Components with Power Control utilize 5 Volts; non-McIntosh components when connected to the C500C might require a higher voltage to switch them On or Off. To change the output voltage to 12 volts follow the steps below:

1. Press the SETUP Push-button once to access the Setup Controller Mode unless the C500C is already in the Setup Controller Mode.
2. Rotate the MENU Control until the words “TRIGA LVL 5V” appears. Refer to figure 14.



Figure 14

3. Rotate the SELECT 2 Control until the Front Panel Alphanumeric Display indicates “TRIGA LVL 12V”. Refer to figure 15.



Figure 15

4. If no other adjustments are to be made at this time, press the SETUP Push-button to exit the Setup Controller Mode or proceed to the next desired Setup Controller Mode for adjustment.

Trigger B Voltage (Power Control)

The Rear Panel Trigger B Jack can provide either a 5 or 12 Volt Output when activated, with 5 Volts as the default. McIntosh Components with Power Control utilize 5 Volts; non-McIntosh components when connected to the C500C might require a higher voltage to switch them On or Off. To change the output voltage to 12 volts follow the steps below:

1. Press the SETUP Push-button once to access the Setup Controller Mode unless the C500C is already in the Setup Controller Mode.
2. Rotate the MENU Control until the words "TRIGB LVL 5V" appears. Refer to figure 16.



Figure 16

3. Rotate the SELECT 2 Control until the Front Panel Alphanumeric Display indicates "TRIGB LVL 12V". Refer to figure 17.



Figure 17

4. If no other adjustments are to be made at this time, press the SETUP Push-button to exit the Setup Controller Mode or proceed to the next desired Setup Controller Mode for adjustment.

Triamp (Balanced Outputs)

The C500P and C500T Preamplifiers provide three Balanced XLR Output Connectors for each channel. One Output is labeled MAIN (non-switched) and two additional Outputs MAIN/SPKR1 and MAIN/SPKR2 (switched On or Off by using the Remote Control). Outputs MAIN/SPKR1 and MAIN/SPKR2 may be configured to remain On along with the MAIN Output for use in systems with three Power Amplifiers per channel. To change the MAIN/SPKR1 and MAIN/SPKR2 Outputs perform the following steps:

1. Press the SETUP Push-button once to access the Setup Controller Mode unless the C500C is already in the Setup Controller Mode.
2. Rotate the MENU Control until the words "TRIAMP OFF" appears. Refer to figure 18.



Figure 18

3. Rotate the SELECT 2 Control until the Front Panel Alphanumeric Display indicates "TRIAMP ON". Refer to figure 19.

Note: The Unbalanced SPKR1 and SPKR2 Main Outputs are still controllable (On or Off) with the Remote Control.



Figure 19

4. If no other adjustments are to be made at this time, press the SETUP Push-button to exit the Setup Controller Mode or proceed to the next desired Setup Controller Mode for adjustment.

D/A Control (McIntosh MDA1000)

When the McIntosh MDA1000 D/A Converter and MCD1000 CD Player are connected to the C500 Controller there are special functions to enhance operation of the D/A Converter with the C500. The following steps activate these functions:

1. Press the SETUP Push-button once to access the Setup Controller Mode unless the C500C is already in the Setup Controller Mode.
2. Rotate the MENU Control until the words "D/A CTRL OFF" appears. Refer to figure 20.



Figure 20

3. Rotate the SELECT 2 Control until the Front Panel Alphanumeric Display indicates "D/A CTRL ON". Refer to figure 21.



Figure 21

4. Rotate the Menu Control until the words "D/A INP1 ON" appears. Refer to figure 22.



Figure 22

In the following step the memory of the C500C will be updated to reflect the assignment of active Digital Inputs on the MDA1000. This will prevent having to go through unused inputs when changing the D/A Inputs by using either the C500 Front Panel Controls or the Remote Control.

5. Rotate the SELECT 2 Control to select On or Off for “D/A INPut 1”.
6. Rotate the SELECT 1 Control to select the next input, “D/A INPut 2”.
7. Rotate the SELECT 2 Control to select On or Off for the next “D/A INPut 2”.
8. Repeat steps 6 and 7 until all seven of the MDA1000 Input Assignments have been entered into the C500 Memory.
9. Rotate the MENU Control until the words “PROG DP SUM” appears. Refer to figure 23.



Figure 23

10. Rotate the SELECT 2 Control to select the Digital Input of the MDA1000 that the MCD1000 is connected to. Refer to figure 24.



Figure 24

11. Press the SETUP Push-button to exit the Setup Controller Mode.

Input Selection and Title Reassignment

The C500 has nine Audio Inputs, which includes seven high level inputs, two dedicated Phono Inputs and two external processor loops. These inputs already have assigned titles that will allow for immediate hookup, operation and enjoyment.

If the default Input Titles for the High Level Inputs do not match up with components in your system they may be reassigned. The following example will illustrate how to rename the AUX Input to DVD2. When the Input Selector is rotated to select what was originally the AUX Input, DVD2 will now appear on the Front Panel Alphanumeric Display.

Notes: 1. Unused Inputs may be switched Off so they will not appear when going through the input source choices using the LISTEN Control, RECORD Control or when using the Remote Control. Refer to figure 25.



Figure 25

2. The Alphanumeric Display will indicate the default Title for the Input number selected with a dot appearing to the right of the Title. Refer to figure 26a.



Figure 26a

3. The Input Titles choices available for the High Level Inputs start with DVD2, AUX2, TUN2, SVR2, CDR2, or CD2.
4. The PHONO MM and PHONO MC Inputs Titles are fixed, however they may be switched On or Off.

1. Press the SETUP Push-button twice to access the Setup Preamp Mode unless the C500C is already in the Setup Preamp Mode.
2. Rotate the MENU Control until the Alphanumeric Display indicates “INPUT 3 TUN•” appears. Refer to figure 26a.
3. Rotate the SELECT 1 Control until the Display indicates “INPUT 2 AUX•”. Refer to figure 26b.



Figure 26b

4. Rotate the SELECT 2 Control until the Display indicates “INPUT 2 DVD2”. Refer to figure 27.



Figure 27

5. Repeat steps 3 and 4 until all the Inputs have the desired Title or are switched Off.
6. If no other adjustments are to be made at this time, press the SETUP Push-button to exit the Setup Preamp Mode or proceed to the next desired Setup Preamp Mode for adjustment.

Data Port Assignment

The Data Control Ports on the C500 Controller by default are assigned to control just one input (1 thru 7) on the Preamplifier.

In the following example there are two McIntosh CD Players, one connected to the CD Balanced Input number 6 and the other CD Player connected to the CDR Unbalanced Input number 5 on the Preamplifier. Both CD Players will share the same DATA PORT number 6 by performing the following steps:

1. Press the SETUP Push-button twice to access the Setup Preamp Mode unless the C500C is already in the Setup Preamp Mode.
2. Rotate the MENU Control until the Alphanumeric Display indicates D PORT _ _ _ _ .



Figure 29

3. Rotate the SELECT 1 Control until the desired Input Title to be changed appears in the Display, e.g. "D PORT CDR 5". Refer to figure 29.
4. Rotate the SELECT 2 Control until the number 2 appears in the Display, e.g. "D PORT CDR 6". Refer to figure 30.



Figure 30

Note: Connect a 1/8 inch Stereo Mini "Y" adapter to Data Port number 6 on the C500 Controller. From each leg of the "Y" adapter connect a Cable to the Data In jacks on each CD Player.

5. If there are any other Data Port re-assignments to be made, repeat steps 3 and 4.

Note: DATA PORTS may also be switched off by selecting "--" using the SELECT 2 Control Refer to figure 31.



Figure 31

6. If no other adjustments are to be made at this time, press the SETUP Push-button to exit the Setup Preamp Mode or proceed to the next desired Setup Preamp Mode for adjustment.

Trim Level Adjustment

Various source components can have slightly different volume levels. This could result in the constant need to readjust the C500 Volume Control when switching between different Input Sources. The Level Input Trim Feature on the C500 Controller allows the adjustment of levels for each of the Source Inputs, so that they have the same relative volume. The Tuner and CD Inputs are used in the following example.

Notes: The possible range of adjustment in volume level is $\pm 6\text{dB}$. The Tape/Record Output Levels are unaffected by any changes in the Level Trim Settings. Any LEVEL Trim adjustments made are retained in permanent memory and can be changed only by performing a new Level Trim Procedure. The Tuner Input Volume Level can serve as a reference or choose another Input

Source that is frequently listened to as the reference. The reference Input Source should be set to a Level of 00.

1. Rotate the SELECT 2 Control to select the Tuner Input and adjust the VOLUME Control to the desired listening level. Refer to figure 32.



Figure 32

Note: If the C500 Controller is in the SETUP Mode, exit before proceeding.

2. Press the SETUP Push-button twice to access the Setup Preamp Mode, unless the C500C is already in the Setup Preamp Mode.
3. Rotate the MENU Control until the words "TRIM 0.0 TUN" appears. Refer to figure 33.



Figure 33

Note: The Level Input Trim can also be set via the Remote Control.

4. If necessary, rotate the SELECT 2 Control until the word TUN appears on the right side of the Front Panel Alphanumeric Display, "TRIM 0.0 TUN".
5. If necessary, rotate the SELECT 1 Control until two zeros appears in the center of the Front Panel Alphanumeric Display, "TRIM 0.0 TUN".
6. Rotate the SELECT 2 Control until the word CD appears on the right side of the Front Panel Alphanumeric Display, "TRIM 0.0 CD". Refer to figure 34.



Figure 34

7. Rotate the SELECT 1 Control until the Volume Level of the CD Input is the same as the Tuner Volume Level. Figure 35 indicates a 3.0dB decrease in the CD Level.



Figure 35

8. Rotate the SELECT 2 Control until the next desired Input Source Name is displayed.
9. Repeat steps 6, 7 and 8 until all the Inputs with sources connected to the C500 have the same relative volume levels when switching between them.

10. If no other adjustments are to be made at this time, press the SETUP Push-button to exit the Setup Preamp Mode or proceed to the next desired Setup Preamp Mode for adjustment.

Trigger Selection

The Trigger A and B Power Control Outputs on the C500 Controller are reassignable from their default settings to activate only when a given Input(s) is selected. To change either Trigger A or B from the default setting perform the following steps:

Note: Power Control Cables coming from the components to be controlled need to be connected to the correct Trigger Jack on the Rear Panel of the C500C to function.

1. Press the SETUP Push-button twice to access the Setup Preamp Mode unless the C500C is already in the Setup Preamp Mode.
2. Rotate the MENU Control until the Alphanumeric Display indicates “TRIG TUN --” . Refer to figure 36.



Figure 36

3. Rotate the SELECT 1 Control until the desired Input Title to be changed appears in the Display, e.g. “TRIG DVD --” .
4. Rotate the SELECT 2 Control until the desired Trigger A or B (in this example the DVD Input will activate the Trigger A Jack) appears in the Display, e.g. “TRIG DVD A” . Refer to figure 37.



Figure 37

Note: Additional Inputs may also be assigned in the same manner to also activate Trigger A.

5. If no other adjustments are to be made at this time, press the SETUP Push-button to exit the Setup Preamp Mode or proceed to the next desired Setup Preamp Mode for adjustment.

Accessory Control

When the Trigger A or B Power Control Outputs on the C500 Controller are used, one of the Triggers may be assigned to switched On or Off by using the ACCessory Push-button on the supplied Remote Control. To select either Trigger A or B for remote operation, perform the following steps:

1. Press the SETUP Push-button twice to access the Setup Preamp Mode unless the C500C is already in the Setup Preamp Mode.
2. Rotate the MENU Control until the Alphanumeric Display indicates “ACC CONTROL --”. Refer to figure 38.



Figure 38

3. Rotate the SELECT 2 Control until the desired Trigger A or B appears in the Display, e.g. “ACC CONTROL A” . Refer to figure 39.



Figure 39

Note: Devices connected to the Trigger (A or B) Jacks will be effected when Trigger (A or B) in SETUP is changed.

4. If no other adjustments are to be made at this time, press the SETUP Push-button to exit the Setup Preamp Mode or proceed to the next desired Setup Preamp Mode for adjustment.

Listen Processor

The C500 Preamplifier has a Listen Processor Loop for connecting an external sound processor. The Listen Processor may be assigned to be active for only those Inputs desired. To activate the Listen Processor Loop and assign Inputs, perform the following steps:

Note: If the Listen Processor is set active for a given Input and no Listen Processor is connected to the C500, no sound will be heard when that Input is selected.

1. Press the SETUP Push-button twice to access the Setup Preamp Mode unless the C500C is already in the Setup Preamp Mode.
2. Rotate the MENU Control until the Alphanumeric Display indicates "LPROC NONE". Refer to figure 40.



Figure 40

3. Rotate the SELECT 2 Control until the word PRESENT appears in the Display, "LPROC PRESENT". Refer to figure 41.



Figure 41

4. Rotate the MENU Control until the Alphanumeric Display indicates "LPROC TUN - -". Refer to figure 42.



Figure 42

5. Rotate the SELECT 2 Control until the word ON appears in the Display, "LPROC TUN ON". Refer to figure 43.



Figure 43

6. Rotate the SELECT 1 Control until the Title of the next desired Input is displayed and then set the Listen Processor to On.
7. Rotate the SELECT 2 Control until the word ON appears in right side of the Display.
8. Repeat steps 6 and 7 until all Inputs requiring the Listen Processor have been set active.
9. If no other adjustments are to be made at this time, press the SETUP Push-button to exit the Setup Preamp Mode or proceed to the next desired Setup Preamp Mode for adjustment.

Record Processor

The C500 Preamplifier has a Record Processor Loop for connecting an external sound processor. The Record Processor may be assigned to be active for only those Inputs desired. To activate the Record Processor Loop and assign Inputs perform the following steps:

Note: If the Record Processor is set active for a given Input and no Record Processor is connected to the C500, no sound signal output will be available for recording purposes when that Input is selected.

1. Press the SETUP Push-button twice to access the Setup Preamp Mode unless the C500C is already in the Setup Preamp Mode.
2. Rotate the MENU Control until the Alphanumeric Display indicates "RPROC NONE". Refer to figure 45.



Figure 45

3. Rotate the SELECT 2 Control until the word PRESENT appears in the Display, "RPROC PRESENT". Refer to figure 46.



Figure 46

4. Rotate the MENU Control until the Alphanumeric Display indicates "RPROC TUN - -". Refer to figure 47.



Figure 47

5. Rotate the SELECT 2 Control until the word ON appears in the Display, "RPROC TUN ON". Refer to figure 48.



Figure 48

6. Rotate the SELECT 1 Control until the Title of the next desired Input is displayed and then set the Record Processor to On.
7. Rotate the SELECT 2 Control until the word ON appears in right side of the Display.
8. Repeat steps 6 and 7 until all Inputs requiring the Record Processor have been set active.
9. If no other adjustments are to be made at this time,



press the SETUP Push-button to exit the Setup Preamp Mode or proceed to the next desired Setup Preamp Mode for adjustment.

Moving Magnet Cartridge Capacitance

The C500 allows the adjustment of the Moving Magnet Capacitive Loading to accommodate a wide variety of cartridge types and turntable/cabling combinations. The range of adjustment is from 50pf to 750pf in 50pf increments. To change the capacitance from the default value of 50pf setting perform the following steps:

1. Press the SETUP Push-button twice to access the Setup Preamp Mode unless the C500C is already in the Setup Preamp Mode.
2. Rotate the MENU Control until the Alphanumeric Display indicates "MM 50 PF". Refer to figure 50.



Figure 50

3. Rotate the SELECT 2 Control until the desired capacitance appears in the Display, e.g. "MM 150 PF". Refer to figure 51.



Figure 51

4. If no other adjustments are to be made at this time, press the SETUP Push-button to exit the Setup Preamp Mode or proceed to the next desired Setup Preamp Mode for adjustment.

Moving Coil Cartridge Resistance

The C500 allows the adjustment of the Moving Coil Resistive Loading to accommodate a wide variety of cartridge types and turntable/cabling combinations. The range of adjustment is from 25 ohms to 1,000 ohms in six increments. To change the resistive load from the default value of 25 ohms setting perform the following steps:

1. Press the SETUP Push-button twice to access the Setup Preamp Mode unless the C500C is already in the Setup Preamp Mode.
2. Rotate the MENU Control until the Alphanumeric Display indicates "MC 25 OHM". Refer to figure 52.
3. Rotate the SELECT 2 Control until the desired resis-



Figure 52

tance appears in the Display, e.g. "MC 200 OHM". Refer to figure 53.

4. If no other adjustments are to be made at this time,



Figure 53

press the SETUP Push-button to exit the Setup Preamp Mode or proceed to the next desired Setup Preamp Mode for adjustment.

Passthru Mode

The C500 can be part of a Multichannel Sound System for SACD, DVD-Audio and Home Theater. The Right and Left Front Channels from a McIntosh A/V Control Center or Surround Decoder can "Passthru" the C500 and onto its associated Power Amplifier(s). The Setup Mode allows the activation of the Passthru Mode and the Selection of the C500 Input that will be used for the Right and Left Front Channels. In the example below, the Right and Left Front Channels from the Multichannel Processor/Decoder will be connected to the CDR Input Jacks on the C500. Refer to page 13 for additional connection information.

1. Press the SETUP Push-button twice to access the Setup Preamp Mode unless the C500C is already in the Setup Preamp Mode.
2. Rotate the MENU Control until the Alphanumeric Display indicates "PASSTHRU OFF". Refer to figure 54.



Figure 54

3. Rotate the SELECT 2 Control until the desired Input appears in the Display, e.g. "PASSTHRU CDR". Refer to figure 55.



Figure 55

4. If no other adjustments are to be made at this time, press the SETUP Push-button to exit the Setup Preamp Mode or proceed to a previous desired Setup Preamp Mode for adjustment.

Setup, con't and Setup Settings Charts

Number	Default Title	New Title	Trim Level	Default Data Port	New Data Port	Trigger Select (A or B)	Listen Processor (ON or OFF)	Record Processor (ON or OFF)	Passthru Input
C500 Preamplifier or C500 Tube Preamplifier									
1	DVD			1					
2	AUX			2					
3	TUNER			3					
4	SRVR			4					
5	CDR			5					
6	CD			6					
7	D/A			7					
8	MM			-	-				
9	MC			-	-				
Additional Settings									
Listen Processor (Present Yes or No)		Record Processor (Present Yes or No)		Moving Magnet (PF)	Moving Coil (OHMS)				

Settings for the C500 Controller						
Display Brightness (1-7)	Meter Illumination (ON or OFF)	Volume Display (% or dB)	Trigger A Voltage (5 or 12)	Trigger B Voltage (5 or 12)	Triamp Outputs (On or OFF)	Accessory Control (Trigger A or B)
McIntosh MDA1000 and MCD1000 Settings						
Input Number	Inputs (On or OFF)	MCD1000 Data Port Number				
1						
2						
3						
4						
5						
6						
7						

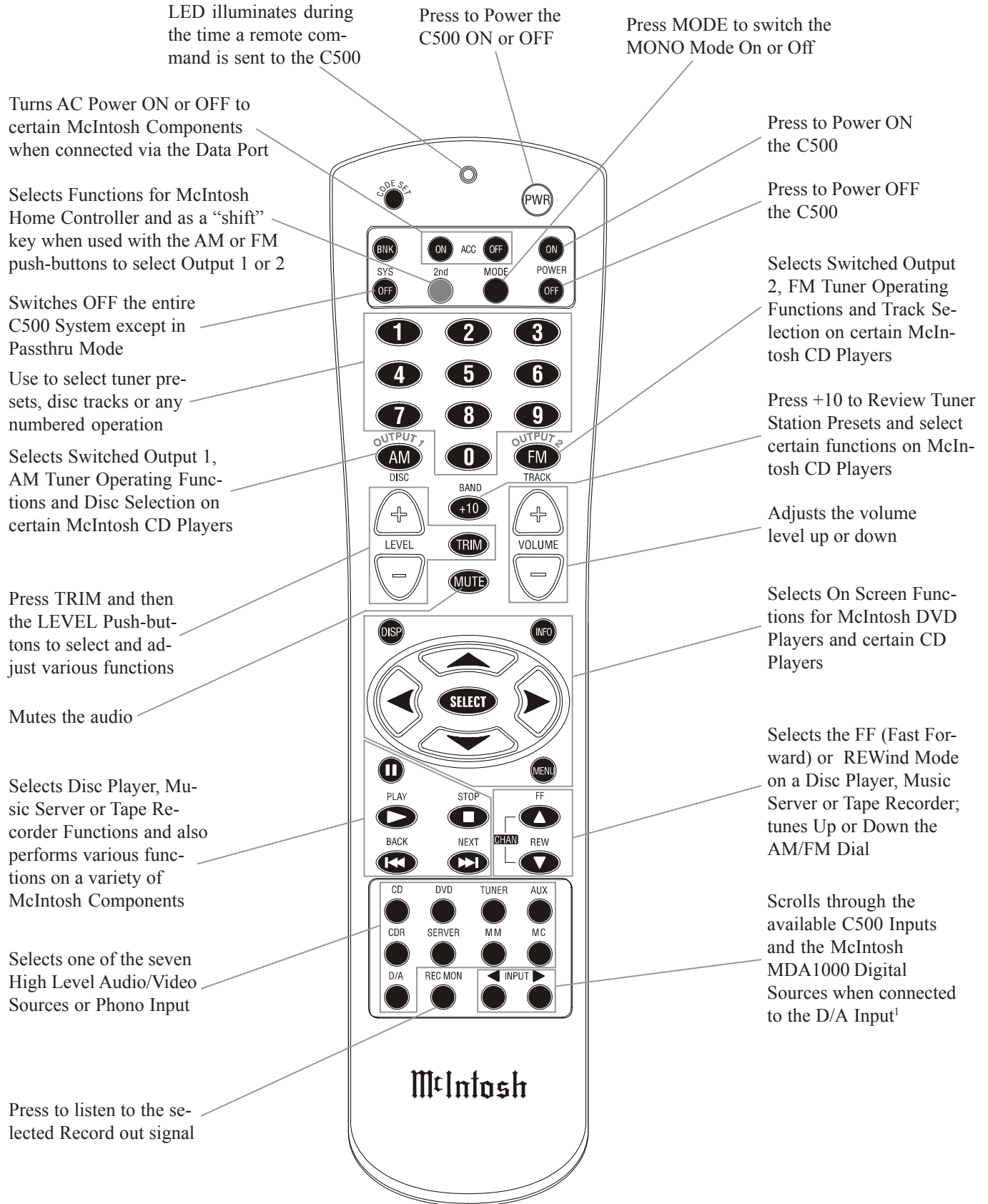

Note: Push-buttons whose function is not identified above are for use with other McIntosh Products.

¹Requires a Data Cable Connection between the C500C and the MDA1000

How to Operate by Remote Control

The supplied Remote Control is capable of directly controlling the functions of contemporary McIntosh Source Components connected to the C500.

Mute

Press the MUTE Push-button to mute audio. The Record Signals present at the CDR and SRVR OUTPUTS are not affected by the MUTE function. The C500 Front Panel Alphanumeric Display will indicate the word MUTE. Press MUTE a second time to unmute audio.

Mono

Press the MODE Push-button to switch Mono Mode On or Off for the selected Listen Signal.

Trim

Press the TRIM Push-button, followed by the LEVEL Up▲ or Down▼ Push-button to select various sound adjustments and functions.

Note: Refer to "How to Operate the C500" starting on page 28 for additional information.

Input Source Selection

Press one of the appropriate Source Push-buttons or the Input ◀ or ▶ Push-buttons to select the desired program source.

Note: When directly selecting sources with Title names ending with a "2" or "3", the appropriate Numbered Push-button needs to be pressed after the push-button with the Titled Name is pressed; e.g. for Input DVD2, press the DVD Push-button followed by the "2" Push-button.

Disc, Server and Tape Functions

Use these push-buttons to operate a DVD Player, CD Player, CD Changer, Music Server or Tape Recorder.

Numbered Push-buttons

Press Push-buttons 0 through 9 to access tuner station presets, tracks on discs or selections on a Music Server.

Disc and Track

Use the DISC and TRACK Push-buttons when a Disc Player or Music Server is being used.

Tuner Push-buttons

Press the AM or FM Push-button to select the desired broadcast band. Press and release the Channel Up▲ or Down▼ Push-button to move from station to station. Press and hold a Channel Up▲ or Down▼ Push-button to move continuously from station to station. Press +10 to start the

automatic brief audition of each of the presets stored in the tuner memory. Press +10 a second time to stop on a station preset and exit the Review process.

Volume

Press the Up▲ or Down▼ VOLUME Push-button to raise or lower the listening volume level.

Note: The Record Signals present at CDR and SRVR OUTPUTS are not affected by volume changes.

Amplifier Selection

Press the 2nd push-button followed by the OUTPUT 1 or 2 push-buttons to control the rear panel OUTPUTS 1, 2 which can feed signals to a power amplifier or other accessory component.

Acc On

Press ACC ON to turn the power ON to a McIntosh Disc Player.

Acc Off

Press ACC OFF to turn the power OFF to a McIntosh Disc Player.

Pause

Press || Pushbutton to perform various functions on a variety of McIntosh Components. It will also pause the playing of a disc or tape player. The || Push-button will also allow for quick exiting from the active menu when in the setup mode. The || Push-button is also used as an Enter Push-button with some McIntosh components.



How to Operate the C500

Power On

The Red LED above the STANDBY/ON push-button lights to indicate the C500 is in Standby mode and is connected to a live AC Outlet. To switch On the C500, press the STANDBY/ON push-button. Refer to figure 64. The Alphanumeric Display will indicate the last input listened to. If this is the first time the C500 is switched on, the display will indicate “15 TUNER”, refer to figure 61.



Figure 61

- Notes: 1. Dependent upon which Preamp (C500P or C500T) is connected to the C500C the Front Panel Alphanumeric Display will indicate different operational messages when switched On, refer to page 32 for additional information.
2. With the C500 Tube Preamp connected to the C500C, the first display on the Alphanumeric Numeric will be “TUBE WARMUP”. Refer to figure 63. The amount of time the display will indicate “TUBE WARMUP” is dependent upon the temperature of the Tubes inside the C500T.



Figure 63

Balance Control

Adjust the BALANCE control as needed to achieve approximately equal listening volume levels in each loudspeaker. Turn the BALANCE to the Left to emphasize the left channel by reducing the level of the right channel. Turn

the BALANCE to the right to emphasize the right channel by reducing the level of the left channel.

As soon as the BALANCE control is turned, the Volume Display reads the balance change from 1 to 107 in one dB steps. Refer to figure 65. After approximately 3 seconds the



Figure 65

Volume Display returns to the Volume reading. To verify the balance setting without changing it, move the control one detent in either direction. The display will indicate the selected balance changes for approximately 3 seconds and then return to the volume display.

The “L” or “R” will illuminate to indicate which channel has been emphasized by the BALANCE control. It is perfectly normal for the BALANCE control to be off the center to achieve the correct listening volume from each loudspeaker in many listening rooms. Listening balance can also vary with different program sources, room acoustics and listening positions relative to the loudspeakers.

Source Selection

Select the desired Listening Source with the Front Panel LISTEN Control or the appropriate Push-Button(s) on the Remote Control. In a similar manner, select the Record Output Source with the Front Panel RECORD Control. When the RECORD Control is rotated, the Front Panel Alphanumeric Display will change to indicate the Title of the Record Input on the left side, the volume level in the center and the Title of the Listen Input on the right side. Both Titles will be the short text form and the display will revert back to the regular display in about six seconds after the rotation of the

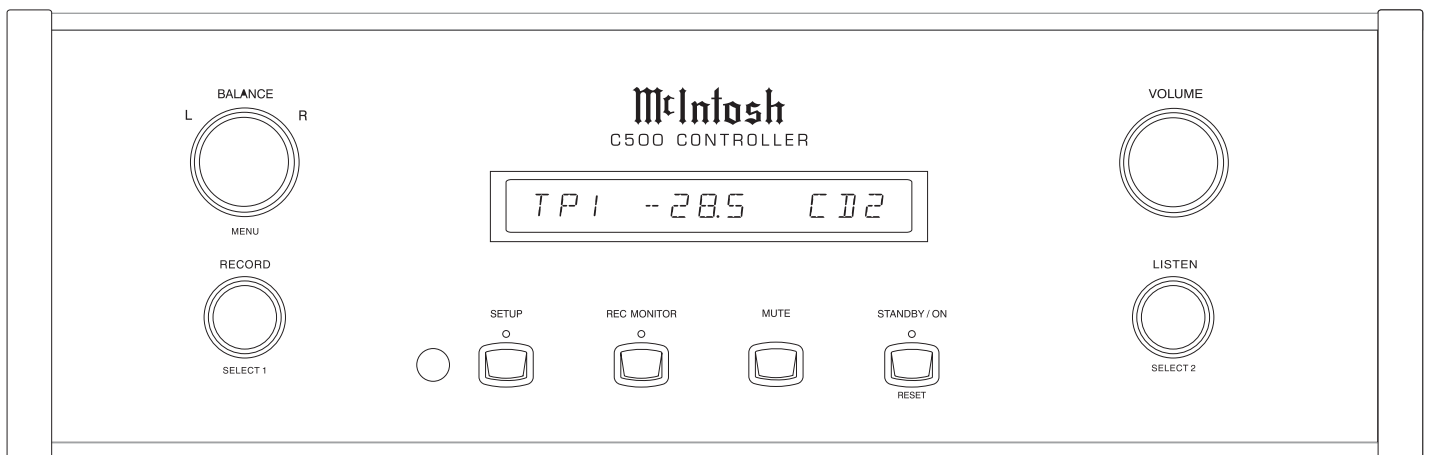

Figure 64

RECORD Selector has stopped. Refer to figure 66.



Figure 66

Note: When the McIntosh MDA1000 is connected to the C500 Controller (refer to page 12) and the “D/A Control” is active (refer to the Setup Controller Mode page 19) the LISTEN Control and the INPUT Push-buttons (◀ and ▶) on the Remote Control will step thru the active MDA1000 Inputs automatically when the D/A Input is selected. When recording from the D/A Input, care should be exercised not to select the D/A for Listening as the MDA1000 Input can change. The D/A Control feature may also be temporarily switched Off (refer to the Setup Controller Mode page 19) when recording the D/A Input.

Volume Control

Adjust the Front Panel VOLUME control or the VOLUME Push-buttons on the Remote Control for the desired listening level.

Note: The default setting of the Front Panel Alphanumeric Display indication of the volume level is percentage. Refer to figure 61. The other choice is decibels, and a change in Setup on page 18 is required for the display to indicate decibels. Refer to figure 67.



Figure 67

Listen and Record External Processors

The activation of both the Listen and Record Processors is fully automatic on a Input per Input basis. To activate the Listen or Record Processor refer to page 23.

Record Monitor

Press the Front Panel REC MONITOR Push-button or the REC MONITOR Push-button on the Remote Control to hear the Signal Source that is available at the Record Out Jacks for recording. The LED above the REC MONITOR Push-button on the Front Panel will illuminate.

Note: The Front Panel Alphanumeric Display will display the Input Title on the Left side of the Display with the Volume Level on the right side. Refer to figure 68.



Figure 68

Setup Mode

Pressing the SETUP Push-button activates the Setup Mode of the C500 and allows customizing of the various Operating Modes, Front Panel Alphanumeric Display and indication of the Firmware Version. The LED above the SETUP Push-button will illuminate. Refer to page 16 for additional information on the SETUP Mode.

Mute

Press the MUTE Push-button to mute audio in all Listen Outputs including headphones and the Front Panel Alphanumeric Display will indicate MUTE in place of the actual volume setting. Refer to figure 69a. Press the MUTE again



Figure 69a

to resume listening. If it is desirable to listen privately with headphones (connected to the Preamplifier Front Jack), press and hold the MUTE Push-button until the Front Panel Alphanumeric Display indicates “HDPH MODE ON”. Refer to figure 69b. Only the Headphones will be active for



Figure 69b

listening. Return to regular listening of Loudspeaker or Headphones by pressing and hold the MUTE Push-button until the Front Panel Alphanumeric Display indicates “HDPH MODE OFF”. Refer to figure 69c.



Figure 69c

How To Make A Recording

The separate RECORD and LISTEN Controls allow the recording from one program source while listening to another. You can also listen (monitor) to the recorded signal off the recording media, a fraction of a second later. You can also listen to the signal at the record outputs by pressing the REC MONITOR push-button.

1. Select the desired program source to record with the Front Panel RECORD Control.
2. Adjust the record level using the recorders volume control.
3. To listen to the signal at the record outputs going to the recorder, press the REC (Record) MONITOR push-button.

- To listen to the playback of the program source just recorded, rotate the LISTEN Control to the desired input.

Note: The C500 RECORD OUTPUTS are not affected by the VOLUME or BALANCE Controls. To listen to a different program source while recording, turn the LISTEN Control to the desired source. The recording process will not be affected and will continue.

Output Meters

The C500's Output Meters indicate the Output Voltage available at the MAIN and SPKR OUTPUT 1 & 2 Jacks to drive Power Amplifiers. Refer to figure 70. The Meters are calibrated in dB (decibels) and respond to all the peaks contained in the musical information. They indicate to an accuracy of at least 95% of a single cycle from a 2000Hz tone burst.

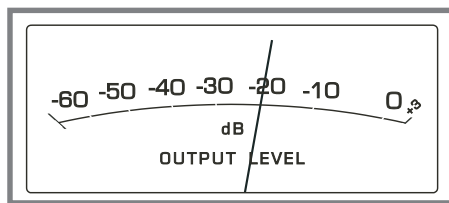

Figure 70

The Meter Electronic Circuitry "Time Stretches" the Meter Drive Signal so the Meter Pointer pauses just long enough for the human eye to see it and is followed by a moderate decay rate.

The following C500 Operating Functions are performed using the supplied Remote Control.

Mono Mode

Press the MODE Push-button once to activate the Front Panel Alphanumeric Display indicating the current mode setting. Pressing the MODE Push-button a second time while the display is indicating the "MONO (On or Off)" will change to the opposite Mode. With the MONO Mode On, the left and right stereo signals will be combined to a mono signal at all Outputs except the Record Outputs. Refer to figures 71 and 72.



Figure 71



Figure 72

Note: The C500 automatically stores into memory for each Listen Input, the Selection of the Mono Mode On or Off. After a Listen Input has been Selected, the Front

Panel Alphanumeric Display will indicate the words "MONO ON" for those Inputs where MONO was previously selected.

Speaker Output 1 and 2

The 2nd Push-button and OUTPUT1 (SPKR1) or OUTPUT2 (SPKR2) Push-buttons on the Remote Control allow the sending of the audio signals to separate power amplifiers connected to the Rear Panel Balanced MAIN/SPKR1 and Unbalanced SPKR1 or MAIN/SPKR2 and Unbalanced SPKR2. It also activates the TRIGGER Jacks SPKR1 & SPKR2 Jacks on the Rear panel of the C500C. Press the desired Push-button (2nd Push-button followed by pressing the OUTPUT1 [SPKR1] or OUTPUT2 [SPKR2]) once to activate the Front Panel Alphanumeric Display indicating the current Speaker Setting. Pressing the Push-button combination a second time while the display is indicating the "SPEAKER1 or SPEAKER2 (On or Off)" will change to the opposite setting. Refer to figures 73 and 74.



Figure 73



Figure 74

Trim

The Trim Push-button on the Remote Control allow for various function and level changes to be made, while listening, without having to go into the SETUP Mode. Any changes made using the Remote Control Trim Push-buttons will change the previous adjustments made in SETUP. By repeated pressing the TRIM Push-button on the Remote Control, the Front Panel Alphanumeric Display will step through the possible adjustments. These include Input Trim Volume Level, Balance Level Adjustments, Stereo or Mono Mode, Speaker 1 On/Off, Speaker 2 On/Off, Display Brightness (1-7)¹, Meter Illumination On/Off¹, the Moving Magnet Phono Input Capacitance¹ and Moving Coil Phono Input Resistance¹. Once the desired Trim function is selected use the LEVEL Up▲ or Down▼ Push-button to make the change. Refer to the chart on the next page:

¹For additional information on these functions refer to SETUP starting on page 16.

Trim Function	Adjustment	Figure Numbers
Input Volume Trim	+6dB to -6dB	75a and b
Balance Level	(Left)107dB to (Right)107dB	76
Mono (Stereo)	On or Off	77a and b
Speaker 1	On or Off	78a and b
Speaker 2	On or Off	79a and b
Display	1-7	80a and b
Meters	On or Off	81a and b
Moving Magnet	50pf to 750pf	82a and b
Moving Coil	25 ohms to 1,000 ohms	83a and b



Figure 75a



Figure 75b



Figure 76



Figure 77a



Figure 77b



Figure 78a



Figure 78b



Figure 79a



Figure 79b



Figure 80a



Figure 80b



Figure 81a



Figure 81b



Figure 82a



Figure 82b



Figure 83a



Figure 83b

How to use the Passthru Mode

When the C500 is connected together with a McIntosh Multichannel A/V Control Center or Surround Decoder and has the PASSTHRU MODE activated, it will automatically turn-on when the A/V Control Center or Surround Decoder is turned On. It will indicate on the Front Panel Alphanumeric Display "PASSTHRU". Refer to figure 84.



Figure 84

The C500C Front Panel Controls, Push-buttons and the Remote Control Push-buttons are deactivated as long as the Passthru Mode is active. The settings for the LISTEN and RECORD Processor and OUTPUTS 1&2 remain unchanged when the C500 is in the Passthru Mode.

Reset of Microprocessors

In the event that the controls of the C500 stop functioning press and hold the STANDBY/ON Push-button. Three to four seconds later the Front Panel Alphanumeric Display will indicate “DETECT SYSTEM”; at this point release the STANDBY/ON Push-button. This will reset the C500 microprocessors. Refer to figure 85.



Figure 85

Note: The above condition is usually caused by either interruptions in AC power and/or major changes in voltage.

Configuration Change

When a change is made to a C500 System (Controller and Preamplifier) by changing the current Preamplifier type (C500P or C500T), the Front Panel Alphanumeric Display will indicate “CONFIG CHANGE” and the LED indicators above the SETUP and REC MONITOR Push-buttons will be flashing. Refer to figures 86 and 87. If there is not to be any changes to the C500 System, but rather reconnecting a Preamplifier that was previously connected to the C500 Controller perform the following:

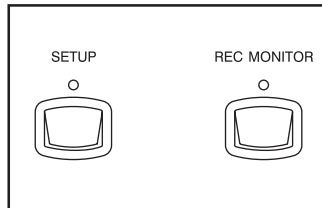

Figure 86



Figure 87

1. Remove the AC Power Cord from the Rear Panel of the C500 Controller.
2. Reconnect the previously connected Preamplifier.
3. Reattach the AC Power Cord.
4. The C500 System will automatically reset itself and will retain any changes that were previously made in the SETUP Mode.

If the change to the C500 System is a result of changing Preamplifier Types (C500P or C500T) then perform the following steps:

1. Remove the AC Power Cord from the Rear Panel of C500 Controller.
2. Connected the Preamplifier(s) to the C500 Controller.

3. Reteach the AC Power Cord.

4. Press and hold the SETUP and REC MONITOR Front Panel Push-buttons until the Alphanumeric Display indicates “DEFAULT RESET”, then release the two Push-buttons. At this point several messages will appear on the Alphanumeric Display depending on the C500 System makeup. Refer to figures 88 thru 91.



Figure 88



Figure 89



Figure 90



Figure 91

5. For any changes from the default settings that are desired go to page 16 SETUP to perform them at this time.

Technical Description

McIntosh Laboratory, the company who introduced the world's first amplifier that could be called "High Fidelity", has done it again. The McIntosh Engineering Staff has created a Preamplifier without compromise, using the most advanced McIntosh circuit design concepts.

The C500 is the third generation of a two chassis design with fully balanced circuitry that started with the introduction of the C100 in 1997. In the two chassis design, the power supplies and digital control circuitry are contained in the Controller Chassis and the second chassis contains the Preamplifier Circuitry. This prevents the possible introduction of hum and noise into the audio signal. In the C500, an additional refinement has been added to help assure total channel isolation, dual mono design. There are two independent power supplies, one for each channel, and the Preamplifier also contains two totally independent preamplifier circuits.

Creating an Preamplifier with this level of performance did not come easily. Many months of design, testing and measuring were required. Extensive controlled listening tests, the ultimate form of measuring, were made before the final design was accepted.

Silent Audio Switching

All of the Audio Signal Switching in the C500 is performed by 50 Electro-Magnetic devices. This includes the selection of the desired Audio Input Source for Listening, for Recording Outputs, External Signal Processing Loop, Final Audio Output Selection and the Audio Muting Function. These Electro-Magnetic devices switch silently, without adding noise to the Audio Signal for the lifetime of the C500 Preamplifier. The Balanced Input Switching Printed Circuit Boards for one channel of the C500 are shown in figure 92.

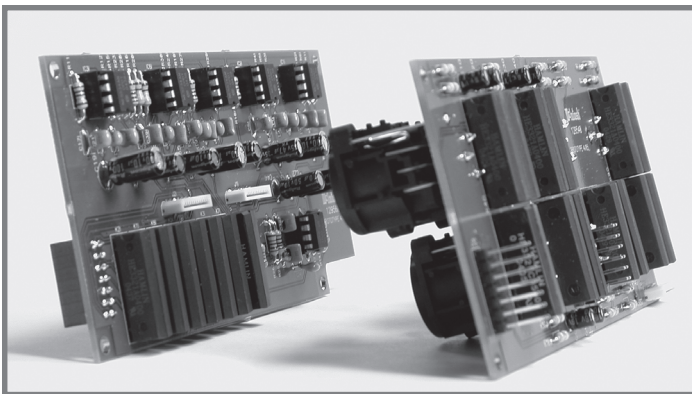

Figure 92

Electro-Magnetic Switching is a proven technology that uses the latest in materials and manufacturing methods. Each switch consists of a glass tube filled with an inert oxygen-free atmosphere and sealed with tiny leads protruding

from either end. These leads extend into the tube and overlap one another with a separation of a few thousandths of an inch. The leads are made from a ferrous material that is influenced by a magnetic field.

They are first plated with gold as a base material, then with rhodium and finally ruthenium. Ruthenium is the best contact material known. Refer to figure 93.

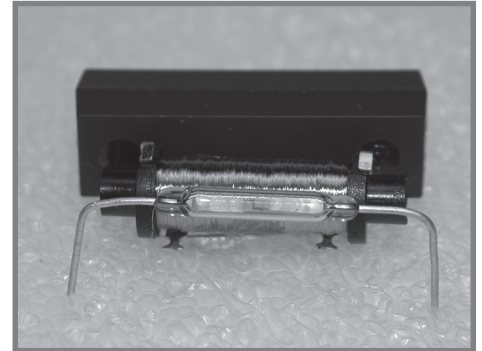

Figure 93

The glass assembly is then placed in the center of a multilayer coil of copper wire. The entire assembly is molded together in a tough shock absorbing material. The switch and coil connectors extend from the bottom in the form of printed circuit board terminals. When a DC voltage is applied to the coil, current flows and creates a magnetic field. The force of the field causes the leads to bend and contact one another inside the sealed glass tube. The inert gas eliminates corrosion of the contacts and insures a low resistance, distortion free switch.

Volume Adjustments

The most frequently operated control on a Preamplifier is the Volume Control. The desired volume level can vary by the type of music, size of our listening room and even the time of day with which we listen. So it is no surprise that McIntosh has devoted a substantial amount of time in pursuit of the "Perfect Volume Control System".

A conventional Mechanical Potentiometer for a volume control is totally unacceptable for use in the C500 Preamplifier. Mechanical Controls have poor tracking especially when it comes to maintaining channel balance and after a period of time they tend to introduce noise into the audio signal, as they are rotated. The one desirable thing they have is the rate of change in volume for degrees of rotation, known as the audio taper. Using Electronic Circuitry for controlling the volume can be designed to be free from noise and maintain channel balance, however the audio taper produced by the typical Electrical Volume Control Circuit is unacceptable for use in the C500, as it does not match the classic McIntosh Volume Control Audio Taper. The C500 incorporates electronic circuitry together with sophisticated firmware to produce electronically the classic McIntosh Volume Control Audio Taper, while maintaining the channel

balance and freedom from control noise.

The Volume Control on the Front Panel of the C500 is actually a special digital optical encoder. As the Volume Control is rotated, a beam of Infra Red Light is picked up by two internal sensors as a series of digital pulses. Refer

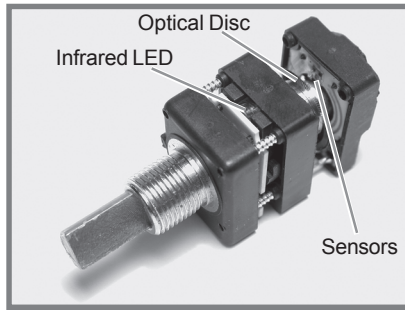

Figure 97

to figure 97. The number of and time between pulses are counted by a Microprocessor which in turn controls the McIntosh designed Precision Electronic Attenuator that provides 213 steps in 0.5dB increments and maintains the channel balance to within ± 0.1 dB.

With most Preamplifiers the Volume Control is placed ahead of the Amplifying Circuitry, refer to figure 98 on the next page, example No. 1. This design provides a great dynamic range and freedom from input overload, but the background noise level is higher especially at lower settings of the volume control. In example No. 2, by placing the Volume Control after the Amplifying Circuitry there is a reduction in dynamic range and input overload of the Preamplifier, but has the benefit of lower background noise levels. The only correct way to design a high performance Preamplifier is with two volume controls, refer to example No.3. This provides the benefits of wide dynamic range, freedom from Input overload and a background noise level that actually goes down as the volume control setting is reduced. The actual improvements in this McIntosh design achieve a noise floor of 118 dB, refer to figure 99. The special controlling circuitry for this dual volume control design is known as the McIntosh "Dynamic Control Multiplexer".

Fully Balanced Circuitry

To compliment the level of performance achieved in one of McIntosh's famous Power Amplifiers with Quad Balanced Circuitry, the C500 Preamplifier also utilizes fully balanced cir-

cuitry. This design topology allows for the virtual cancellation of all forms of distortion, both audible and measurable, along with extremely low background noise levels.

In the typical Preamplifier, one set of circuits have to amplify the positive and negative going parts of the audio sound wave form. In the C500, the implementation of fully balanced circuitry has the positive going audio sound waves amplified by one set of circuits. In a similar manner the negative going audio sound waves are amplified by another set of circuits. Refer to figure 100. Audio signals connected

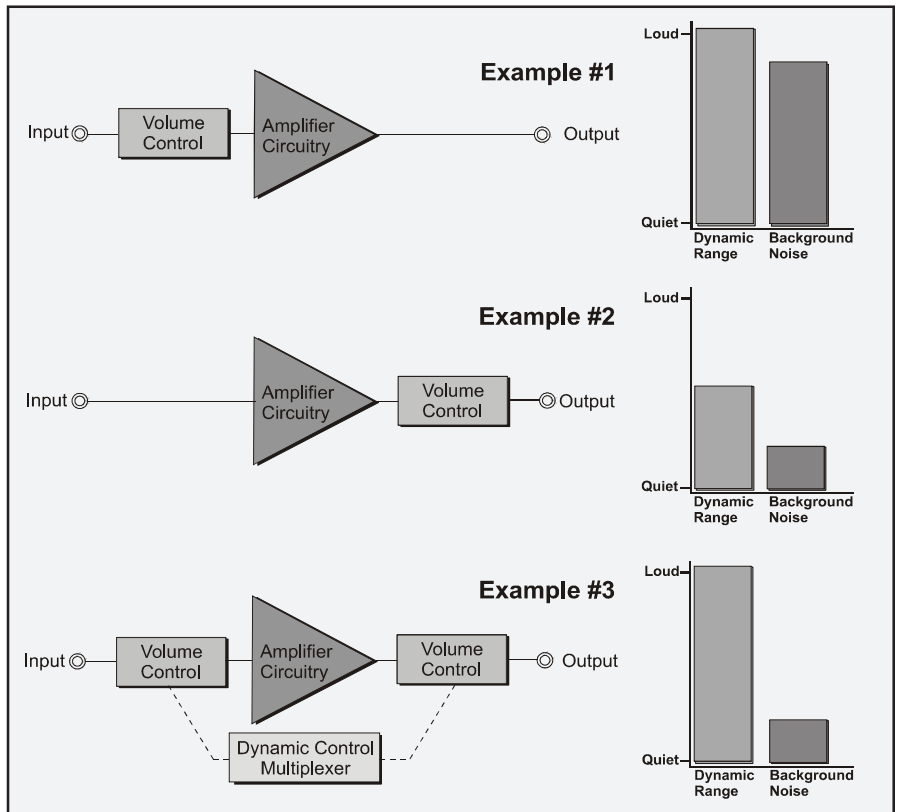

Figure 98

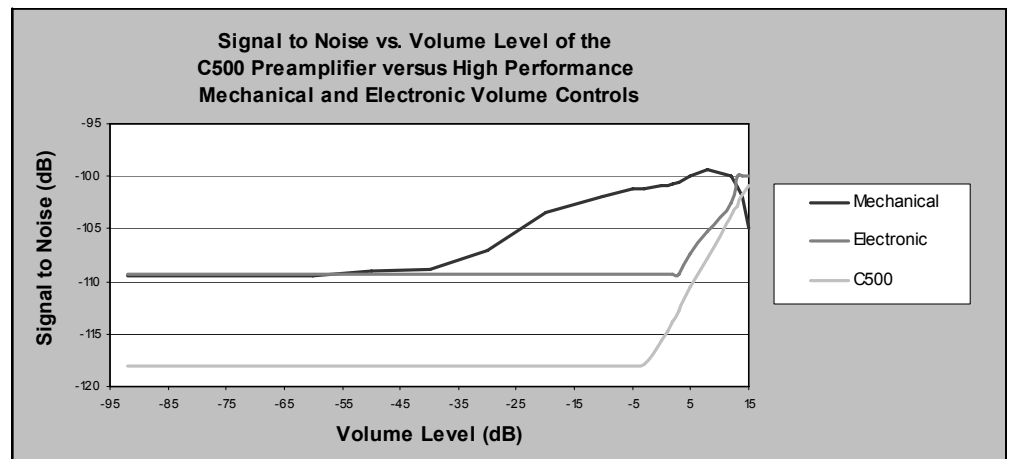

Figure 99

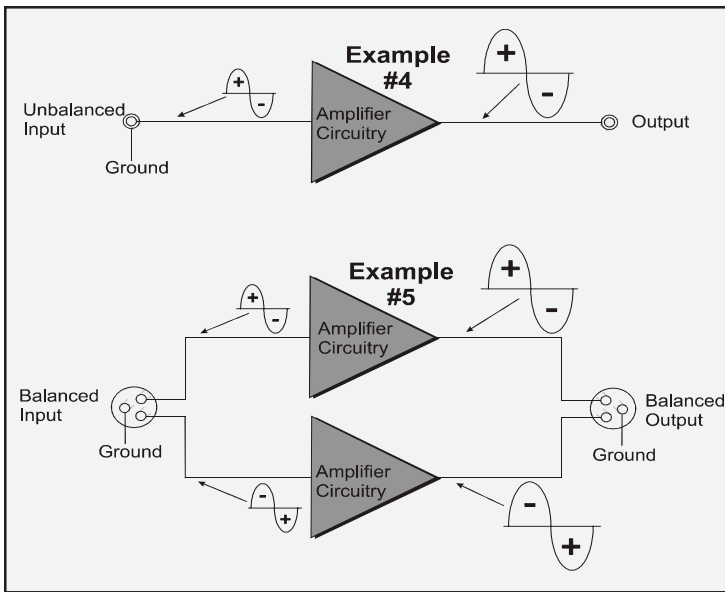

Figure 100

to the unbalanced Inputs of the C500 are first converted to a balanced signal before they are amplified. In a similar manner the balanced audio signals are converted to unbalanced signals before they are available to the unbalanced outputs jacks.

Moving Coil Preamplifier

One of the popular types of Phono Cartridges for Turntables used today are "Moving Coil". Due to their design, the Moving Coil Cartridge's output voltage is typically in the range of 300 to 500 microvolts (millionth of a volt) and thus requires additional amplification in order to match the output voltage of a "Moving Magnet/Induced Moving Magnet" cartridge type with 2.5 to 10 millivolts (thousandths of a volt). The lower the output voltage of the cartridge, the greater the level of amplification required and thus the greater potential for higher noise levels being generated by the circuitry.

McIntosh has designed a new Totally Shielded Moving Coil Preamplifier Module using special ultra low noise circuitry with out the need for a step-up transformer. Refer to figure 101. The C500 utilizes a double filtered power supply design, just for the Moving Coil Preamplifier Module. It offers the ability to change the input impedance from 25 ohms to 1000 ohms in six steps to match a wide variety of Moving Coil Cartridges.



Figure 101

Logic Controlled Circuitry

All Inputs, Outputs, Data Ports, Power Control Outputs and Trigger Outputs are controlled by Logic Circuits in the C500C. The microprocessor is the heart of the Logic Circuits and is controlled by McIntosh developed software. It implements all commands received from the Front Panel Controls or the supplied Remote Controls and indicates them on the Alphanumeric Display. Refer to figure 102.

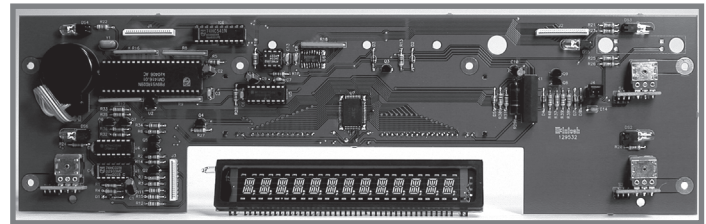

Figure 102

When McIntosh Source Components are connected to C500C Data Ports, basic command functions from the C500 Remote Control are passed on to those components, thus allowing one Remote Control to operate an entire McIntosh Audio System. The Logic Circuits also sense whether the C500 Preamplifier or C500 Tube Preamplifier is connected to the C500 Controller and adjusts the operational functions automatically.

Meter and Circuitry

The lack of accurate performance in ordinary meters has presented difficult and complex problems. Ordinary meters are incapable of indicating the short interval information in a sound wave. Refer to figure 103. The mass of the meter movement is too great to respond to the nearly instantaneous changes in music program material. That short interval information can have a duration less than as one-half of one thousandth of a second. Even if the meter were capable of such high velocity movement, the human eye could not perceive the displayed information. McIntosh solved both

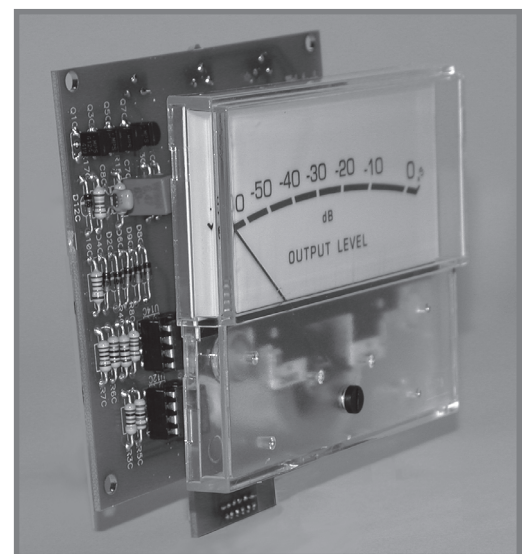

Figure 103

problems electrically. By developing electronic circuits the meters are made to respond to short intervals with an accuracy of 95%! To permit the eye to see such high speed motion, the electronic circuits that drive the meter pointer are time stretched. Special logarithmic circuitry allows the meter to indicate a 60dB plus range, without resorting to a Meter Range Switch.

Power Supply Circuits

To compliment the design of the C500, there are two identical fully regulated power supplies, one for each channel. The C500 Controller contains both low and high voltage regulated power supplies for each channel. It also supplies the appropriate voltages to meet the different requirements of the C500 Preamplifier and C500 Tube Preamplifier. The special "R" core transformers, one for each channel, supply the necessary voltage/current for the low and high voltage regulated circuitry and are housed in shielded enclosures. Refer to figure 104.

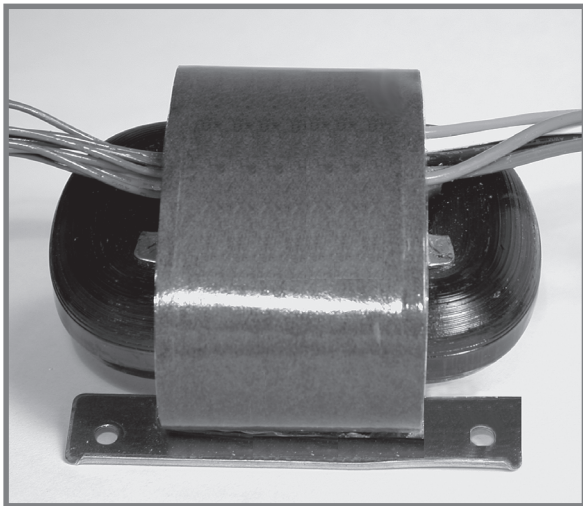

Figure 104

Most owners desire one power switch for the whole audio system. The C500 Controller is equipped with circuits providing remote Power Control On/Off signals to McIntosh Source Components and Power Amplifiers. When the C500C is switched On, a digital "1" (+5V) signal changes the operational state of digital control circuitry and a DC voltage is sent to the Power Control Main Jacks. There are also special Power Control Jacks (Triggers and Passthru) and together with options in SETUP allow for the customizing of the Power Control Control Signals In for specific functions.

Block Diagrams

Refer to folded sheet "Mc2B" for the C500 Controller and C500 Preamplifier Block Diagrams.

Specifications C500 Preamplifier

Frequency Response

+0, -0.5dB from 10Hz to 40,000Hz

Total Harmonic Distortion

0.002% maximum from 20Hz to 20,000Hz

Signal To Noise Ratio

High Level, 100dB

Phono, 88dB

Maximum Voltage Output

12V RMS Unbalanced (Spkr1 and Spkr2 Outputs)

25V RMS Balanced (Main, Spkr1 and Spkr2 Outputs)

Output Impedance

220 ohms (Unbalanced and Balanced Outputs)

Sensitivity

High Level, 450mV for 2.5V rated output

Phono MM, 4.5mV for 2.5V rated output

Phono MC, 0.45mV for 2.5V rated output

Input Impedance

High Level: 22K ohms

Phono:

MM, 47K ohms; 50 to 750pF, in 50pF steps

MC: 25, 50, 100, 200, 500 or 1,000 ohms; 100pF

Maximum Input Signal

High Level:

5V Unbalanced

10V Balanced

Phono:

MM, 50mV

MC, 5mV

Voltage Gain

High Level Input to Record Output: 0dB

High Level Input to Main Output: 15dB

Phono (Moving Magnet) to Record Output: 40dB

Phono (Moving Coil) to Record Output: 60dB

Specifications C500 Tube Preamplifier

Frequency Response

+0, -0.5dB from 10Hz to 20,000Hz

Total Harmonic Distortion

0.05% maximum from 20Hz to 20,000Hz

Signal To Noise Ratio

High Level, 93dB

Phono, 80dB

Maximum Voltage Output

10V RMS Unbalanced (Spkr1 and Spkr2 Outputs)

20V RMS Balanced (Main, Spkr1 and Spkr2 Outputs)

Output Impedance

220 ohms (Unbalanced and Balanced Outputs)

Sensitivity

High Level, 450mV for 2.5V rated output

Phono MM, 4.5mV for 2.5V rated output

Phono MC, 0.45mV for 2.5V rated output

Input Impedance

High Level: 22K ohms

Phono:

MM, 47K ohms; 50 to 750pF, in 50pF steps

MC: 25, 50, 100, 200, 500 or 1,000 ohms; 100pF

Maximum Input Signal

High Level:

5V Unbalanced

10V Balanced

Phono:

MM, 50mV

MC, 5mV

Voltage Gain

High Level Input to Record Output: 0dB

High Level Input to Main Output: 15dB

Phono (Moving Magnet) to Record Output: 40dB

Phono (Moving Coil) to Record Output: 60dB

Tube Compliment

Phono Circuitry:

4 - 12AX7A

High Level Circuitry:

4 - 12AX7A



Specifications C500 Controller

Power Requirements

100 Volts, 50/60Hz at 75 watts
110 Volts, 50/60Hz at 75 watts
120 Volts, 50/60Hz at 75 watts
220 Volts, 50/60Hz at 75 watts
230 Volts, 50/60Hz at 75 watts
240 Volts, 50/60Hz at 75 watts

Note: Refer to the rear panel of the C500 Controller for the correct voltage.

General Specifications

Overall Dimensions

C500C:

Width is 17-1/2 inches (44.45cm)
Height is 6 inches (15.24cm) including feet
Depth is 24 inches (61.00cm) including the Front Panel, Knobs and Interconnect Cables¹

C500P:

Width is 17-1/2 inches (44.45cm)
Height is 6 inches (15.24cm) including feet
Depth is 23 inches (58.42cm) including the Front Panel and Interconnect Cables¹

C500T:

Width is 17-1/2 inches (44.45cm)
Height is 6 inches (15.24cm) including feet
Depth is 23 inches (58.42cm) including the Front Panel and Interconnect Cables¹

Weight

C500C - 30.1 pounds (17.7 kg) net
46.5 pounds (27.9 kg) in shipping carton
C500P - 25.1 pounds (15.0 kg) net
41.5 pounds (24.3 kg) in shipping carton
C500T - 26.4 pounds (15.4 kg) net
42.8 pounds (24.8 kg) in shipping carton

¹ The Custom Interconnect Cables are supplied with the C500 Preamplifier and C500 Tube Preamplifier. They are the ONLY cables to be used for connecting a C500 Controller to the C500 Preamplifier or C500 Tube Preamplifier.

Packing Instructions

In the event it is necessary to repack the equipment for shipment, the equipment must be packed exactly as shown below. It is very important that the four feet are attached to the bottom of the equipment. This will ensure the proper equipment location on the bottom pad. Failure to do this will result in shipping damage.

Use the original shipping carton and interior parts only if they are all in good serviceable condition. If a shipping carton or any of the interior part(s) are needed, please call or write Customer Service Department of McIntosh Laboratory. Please see the Part List for the correct part numbers.

Note: Unless instructed otherwise, please return the McIntosh Custom Interconnect Cables along with the C500 Preamplifier and/or C500 Tube Preamplifier. Please do not return the Remote Controls or Accessories, unless instructed otherwise.

Quantity	Part Number	Description
1	033838	Shipping carton only
4	033837	End cap
1	033836	Inside carton only
1	034414	Top pad (foam)
1	034301	Bottom pad
4	017937	Plastic foot
4	400159	#10-32 x 3/4" screw
4	404080	#10-7/16" Flat washer

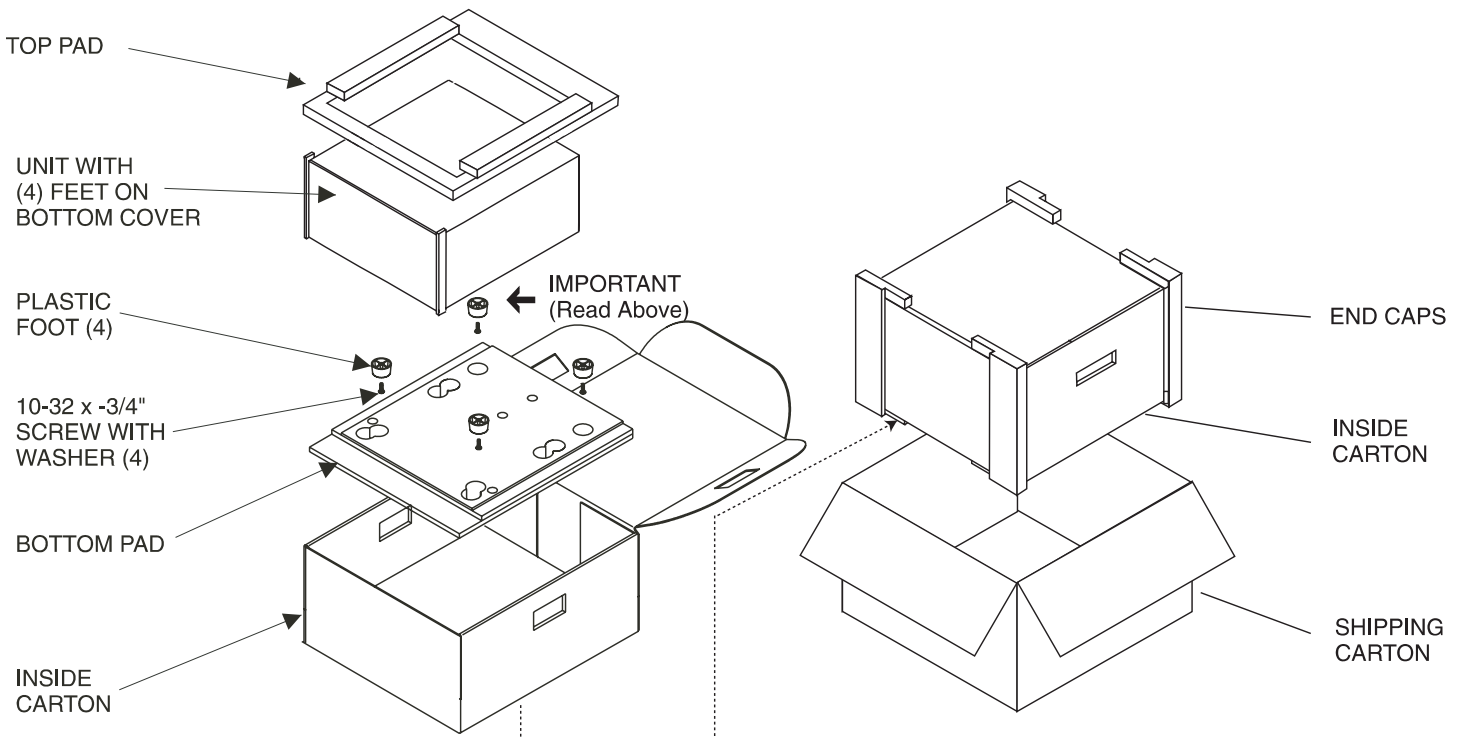



McIntosh Laboratory, Inc.
2 Chambers Street
Binghamton, NY 13903

The continuous improvement of its products is the
policy of McIntosh Laboratory Incorporated who
reserve the right to improve design without notice.
Printed in the U.S.A.

McIntosh Part No. 04105400