

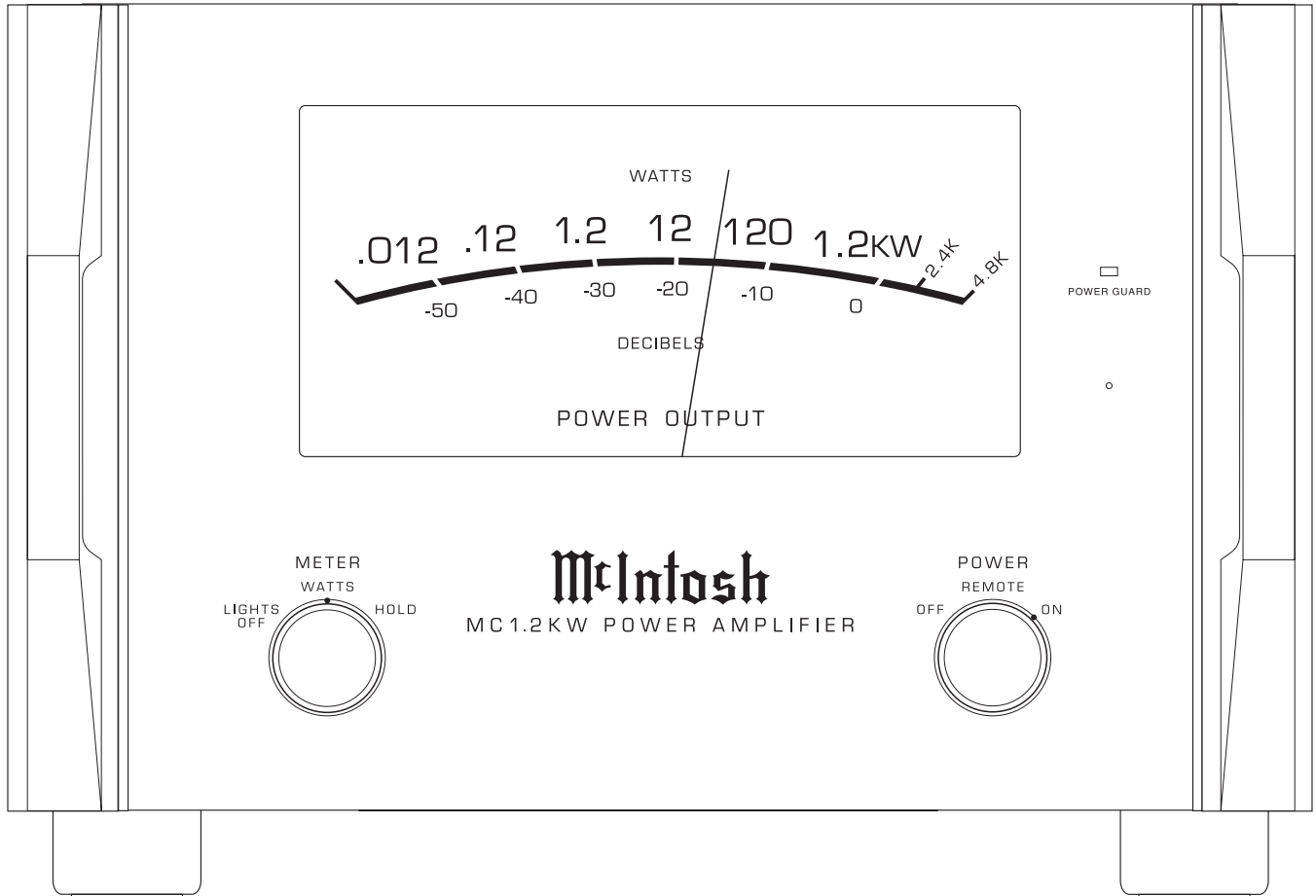

# MC1.2KW

## POWER AMPLIFIER

SERIAL NO. YF1001 And Above



### CONTENTS

Performance Specifications.....	2	Input Schematic and PCB .....	16
Notes.....	2	Capacitor Schematic and PCB .....	17 - 18
Rear Panel .....	3	Meter Schematic and PCB .....	19 - 22
Section Location.....	4	Lamp Schematic and PCB.....	23 - 24
Block Diagram .....	5 - 6	Light Schematic and PCB.....	25
Interconnection Diagram.....	7 - 8	Power Guard Schematic and PCB.....	26
Heatsink Schematic and PCB.....	9 - 10	Parts List .....	29 - 32
Heatsink Slave Schematic and PCB.....	11 - 12	Repacking Instruction .....	33
Driver Schematic and PCB.....	13 - 15		

# SERVICE MANUAL

# PERFORMANCE SPECIFICATIONS

## Power Output

Minimum sine wave continuous average power output is:

- 1,200 watts into 2 ohm load
- 1,200 watts into 4 ohm load
- 1,200 watts into 8 ohm load

## Output Load Impedance

2, 4 or 8 ohms

## Rated Power Band

20Hz to 20,000Hz

## Total Harmonic Distortion

0.005% maximum harmonic distortion at any power level from 250 milliwatts to rated power, 20Hz to 20,000Hz

## Dynamic Headroom

2dB

## Frequency Response

+0, -0.25dB from 20Hz to 20,000Hz  
+0, -3dB from 10Hz to 100,000Hz

## Input Sensitivity (for rated output)

2.5 Volt Unbalanced  
5 Volt Balanced

## Signal To Noise Ratio (A-Weighted)

120dB below rated output, Unbalanced  
124dB below rated output, Balanced

## Intermodulation Distortion

0.005% maximum, if the instantaneous peak power output does not exceed twice the rated power output for any combination of frequencies from 20Hz to 20,000Hz.

## Wide Band Damping Factor

Greater than 40

## Input Impedance

10,000 ohms

## Power Guard

Less than 2% THD with up to 14dB overdrive at 1,000Hz

## Power Requirements

100 Volts, 50/60Hz at 15 Amps  
110 Volts, 50/60Hz at 12.5 Amps  
120 Volts, 50/60Hz at 12 Amps  
220 Volts, 50/60Hz at 7.5 Amps  
230 Volts, 50/60Hz at 6.5 Amps  
240 Volts, 50/60Hz at 6.5 Amps  
Standby: 0.5 watts

*Note: Refer to the rear panel of the MCI.2KW for the correct voltage.*

## Overall Dimensions

Width is 17-3/4 inches (45.09cm)  
Height is 12-5/16 inches (31.27cm) including feet  
Depth is 22 inches (55.88cm) including the Front Panel and Cables

## Weight

147 pounds (66.7 kg) net, 172 pounds (78.0 kg) in shipping carton

## Shipping Carton Dimensions

Width is 31 inches (78.74cm)  
Depth is 28 inches (71.12cm)  
Height is 17-1/4 inches (43.82cm)

## NOTES

1. The heavy lines on the schematic denote the primary signal path.
2. Unless otherwise noted, all voltages indicated on the schematics are measured under the following conditions:
  - a. AC input at rated voltage marked on rear panel.
  - b. All voltages are +/-10% with respect to ground. A high impedance (10 megaohm) voltmeter must be used.
3. Unless otherwise specified:
  - a. Resistor values are in ohms.
  - b. Capacitor values are microfarads (uF).
  - c. Inductor values are in microhenries (uH).
4. On PC board drawings, Square pad indicates:
  - a. Polarized Capacitors - Positive
  - b. Diodes - Cathode
  - c. Others - Pin 1
5. **WARNING**  
Parts marked with the symbol  have critical characteristics. Use only replacement parts recommended by the manufacturer.

# REAR PANEL

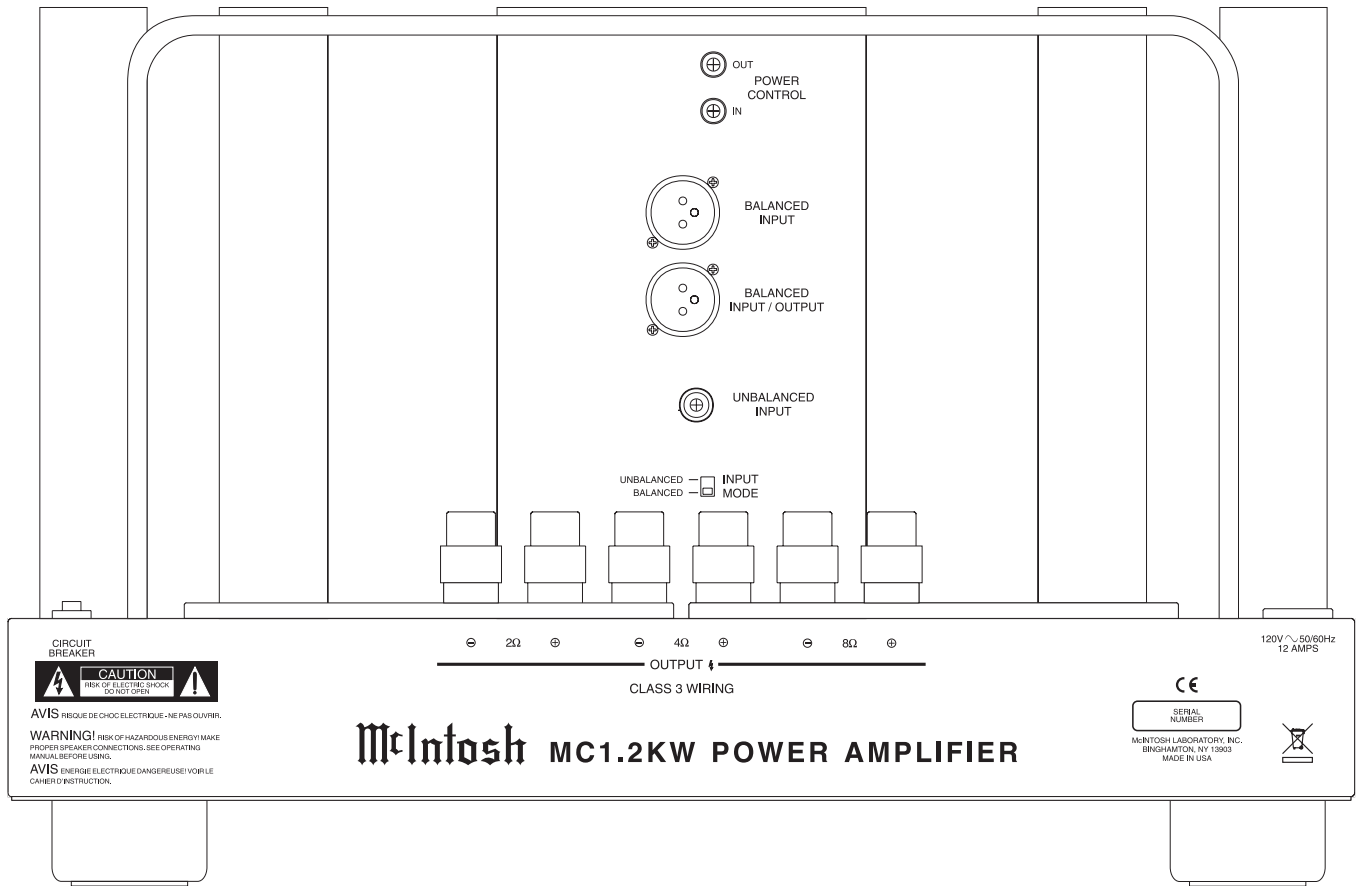

# SECTION LOCATIONS

TOP VIEW WITH COVER REMOVED

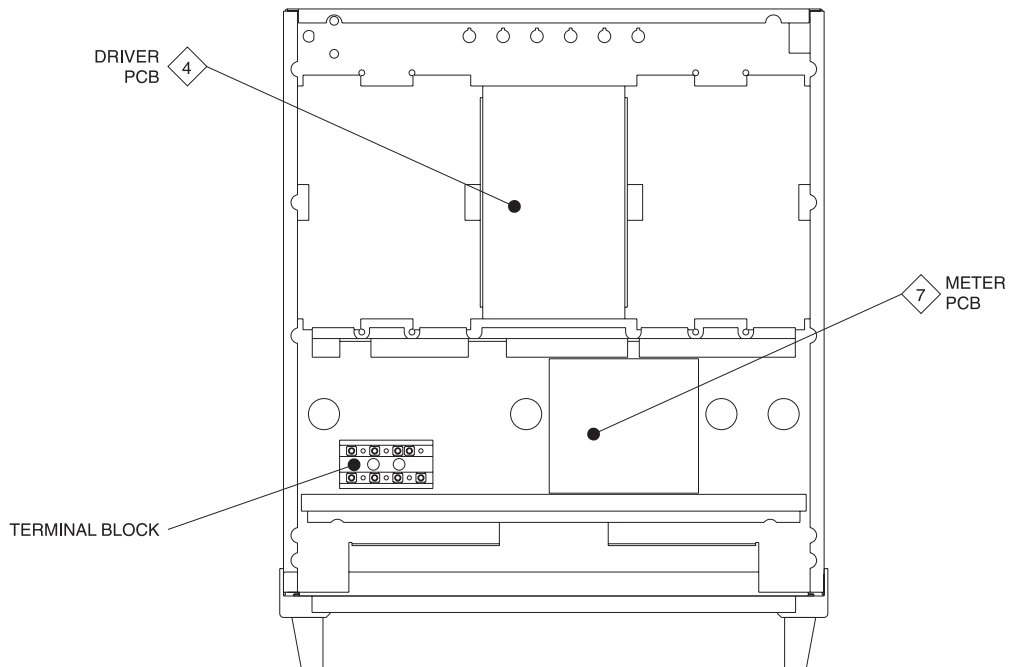
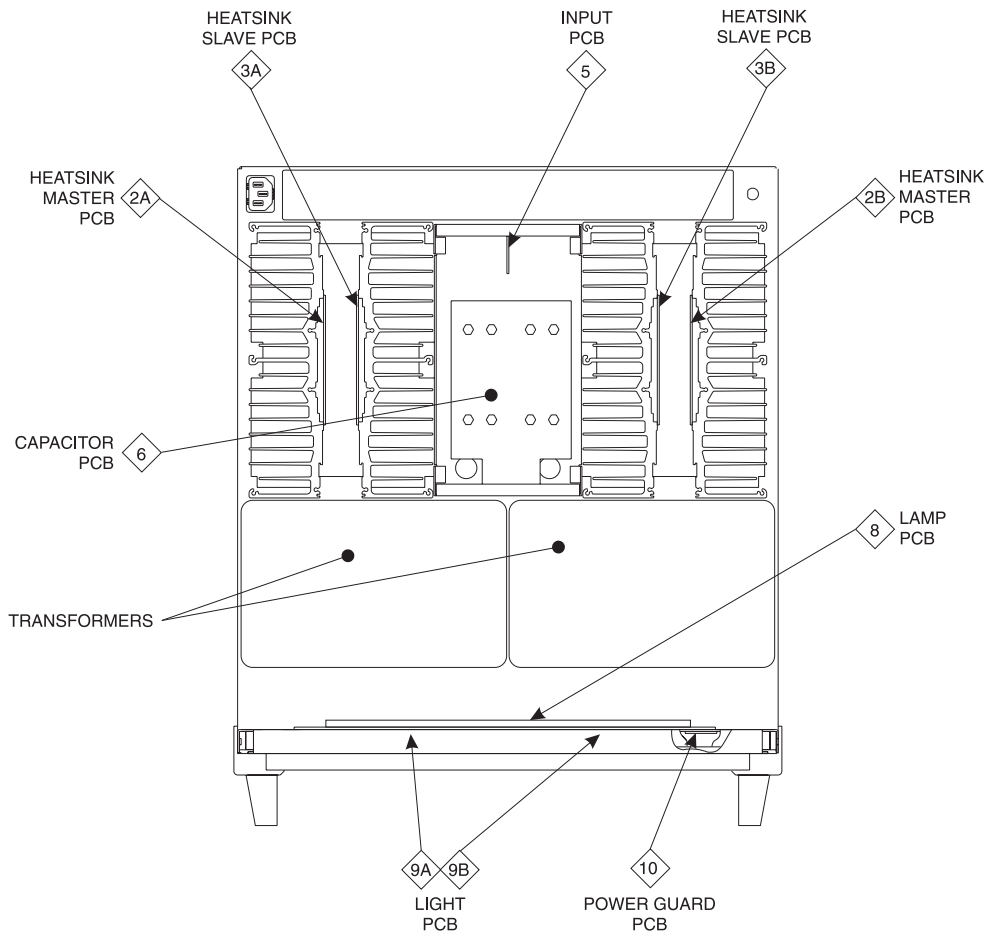

BOTTOM VIEW WITH COVER REMOVED

# BLOCK DIAGRAM

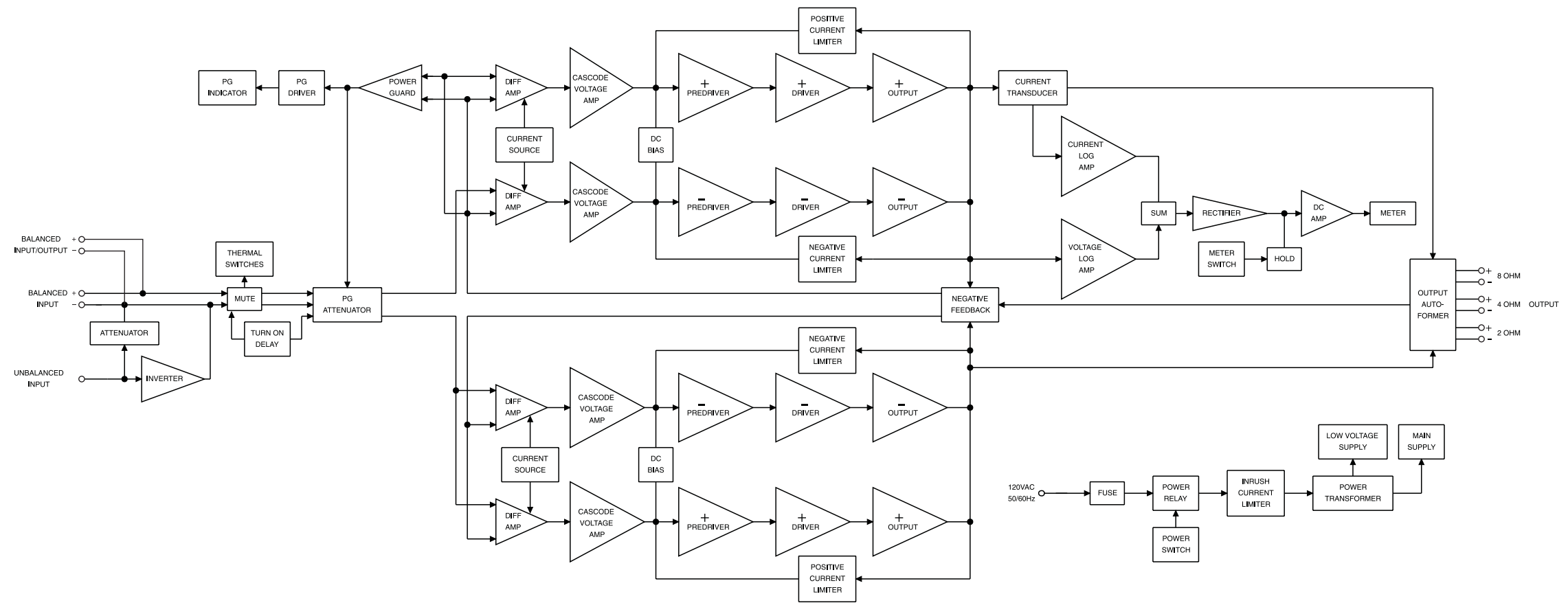

# 1 INTERCONNECT

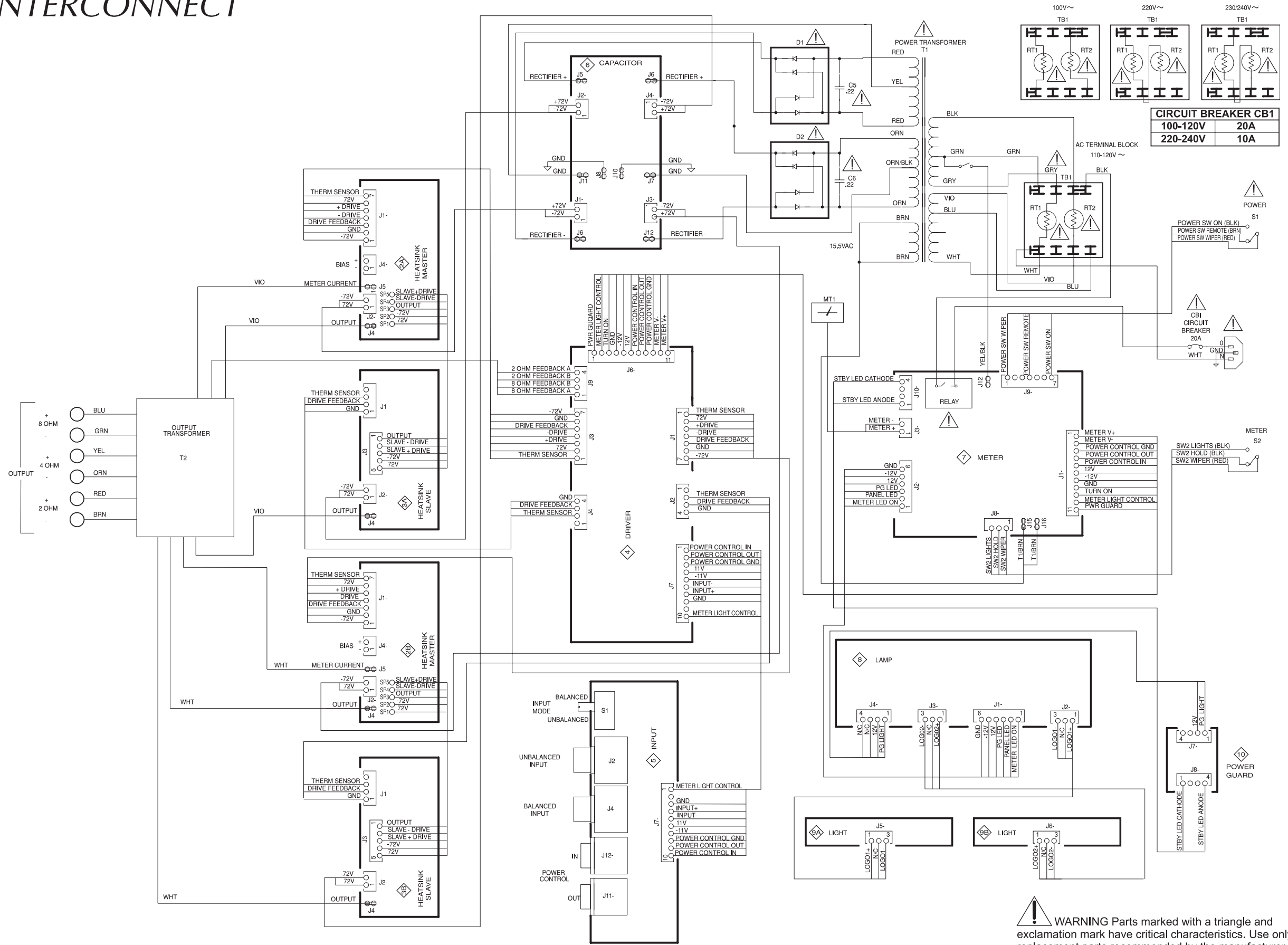

**WARNING** Parts marked with a triangle and exclamation mark have critical characteristics. Use only replacement parts recommended by the manufacturer.

**2A 2B** HEATSINK MASTER 749485 SCH and PCB

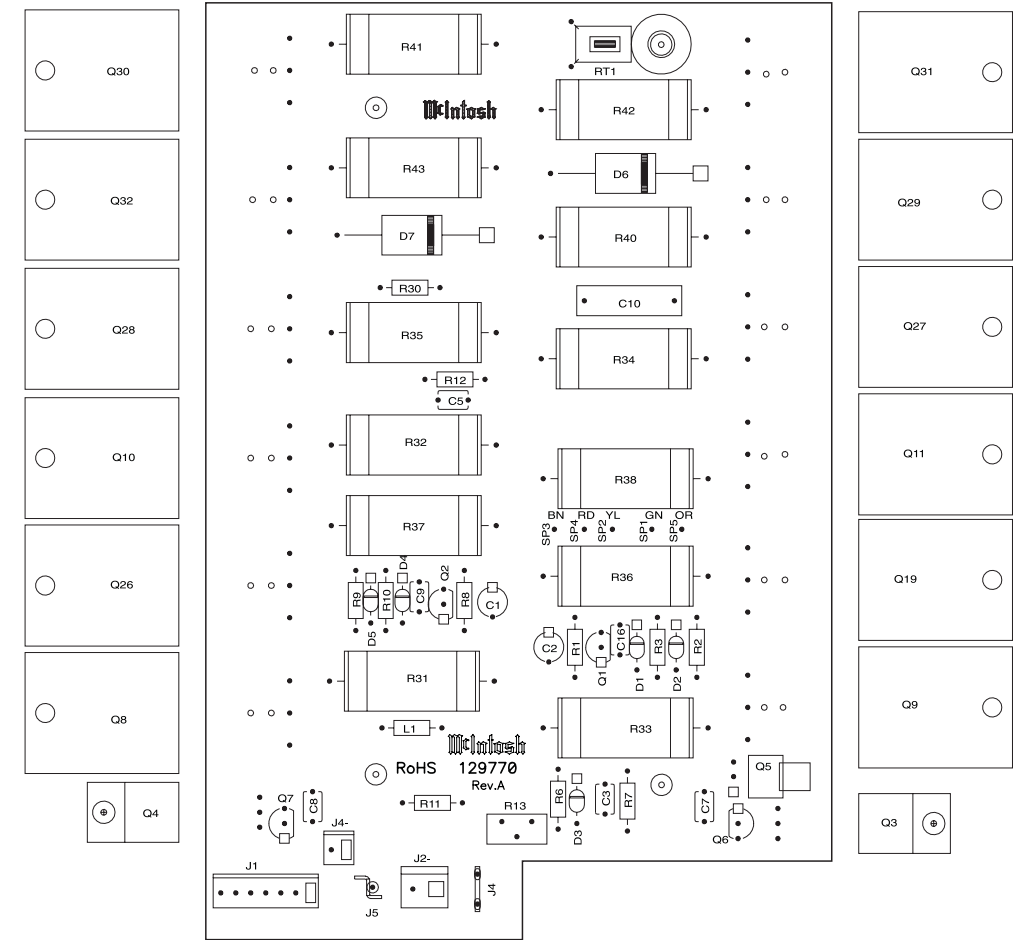
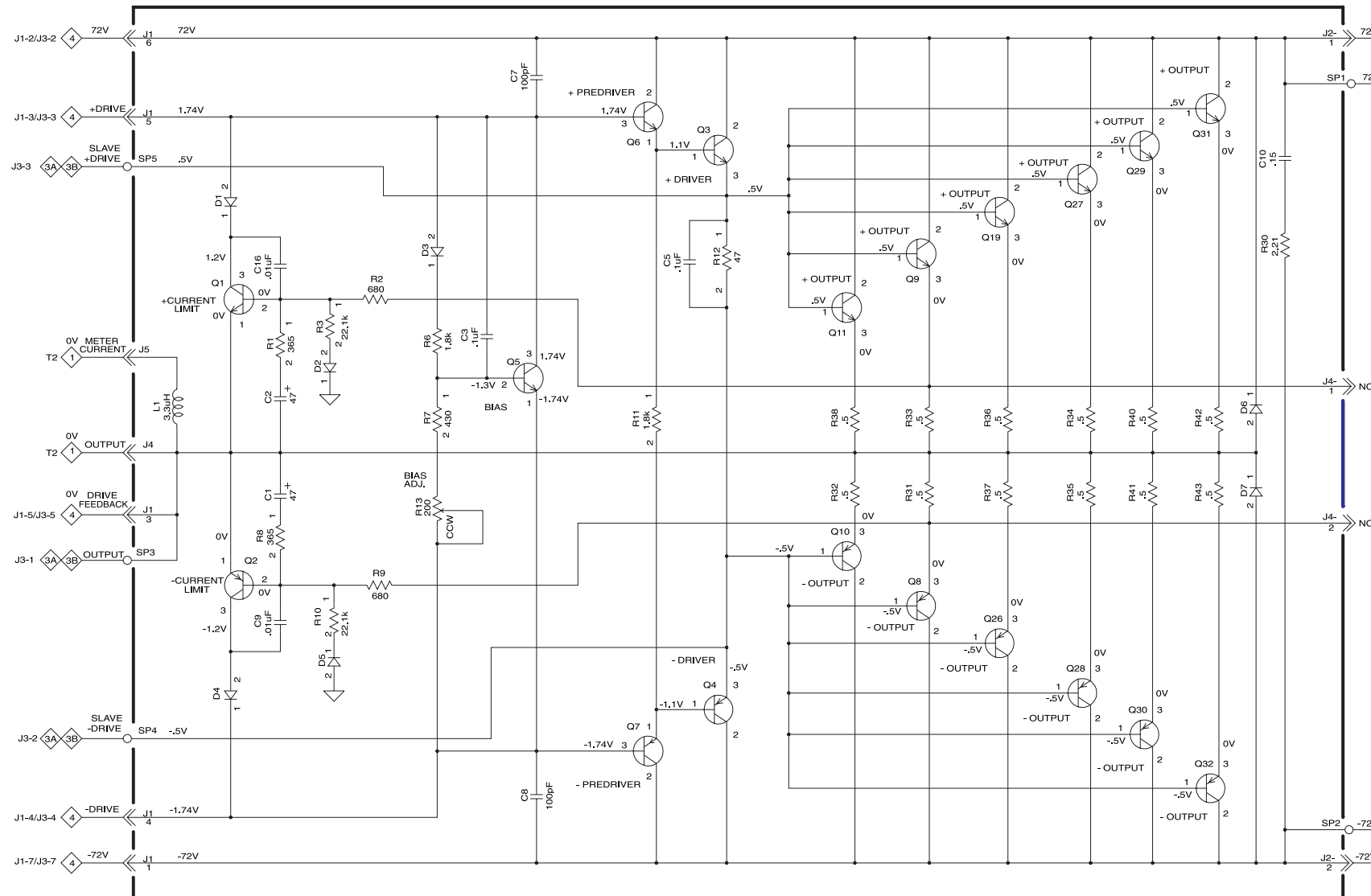

**BIAS ADJUSTMENT**  
 OPERATE THE AMPLIFIER FOR 5 MINUTES  
 WITH NO INPUT SIGNAL.  
 HEATSINKS MUST BE COOL.  
 ADJUST R13 FOR 18±2mV ACROSS  
 PINS 1 & 2 OF J4. ADJUST BOTH MASTER  
 HEATSINKS.

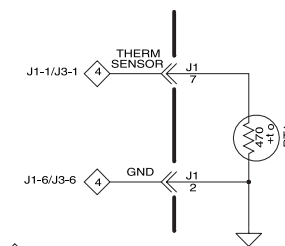

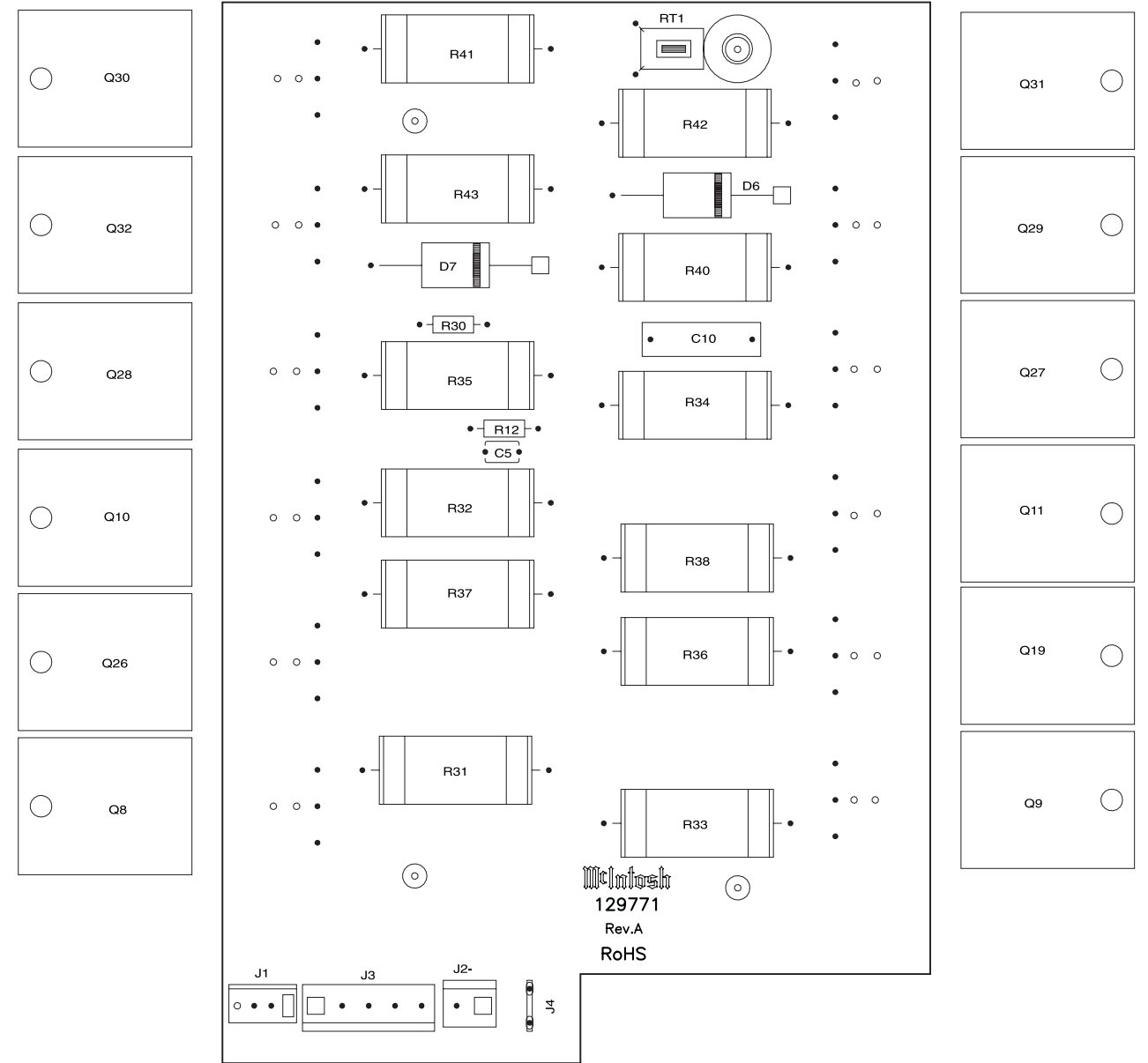
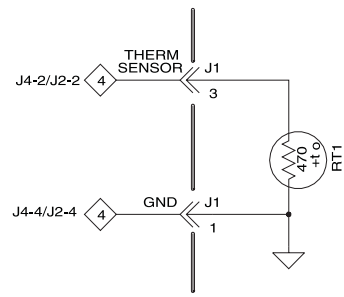
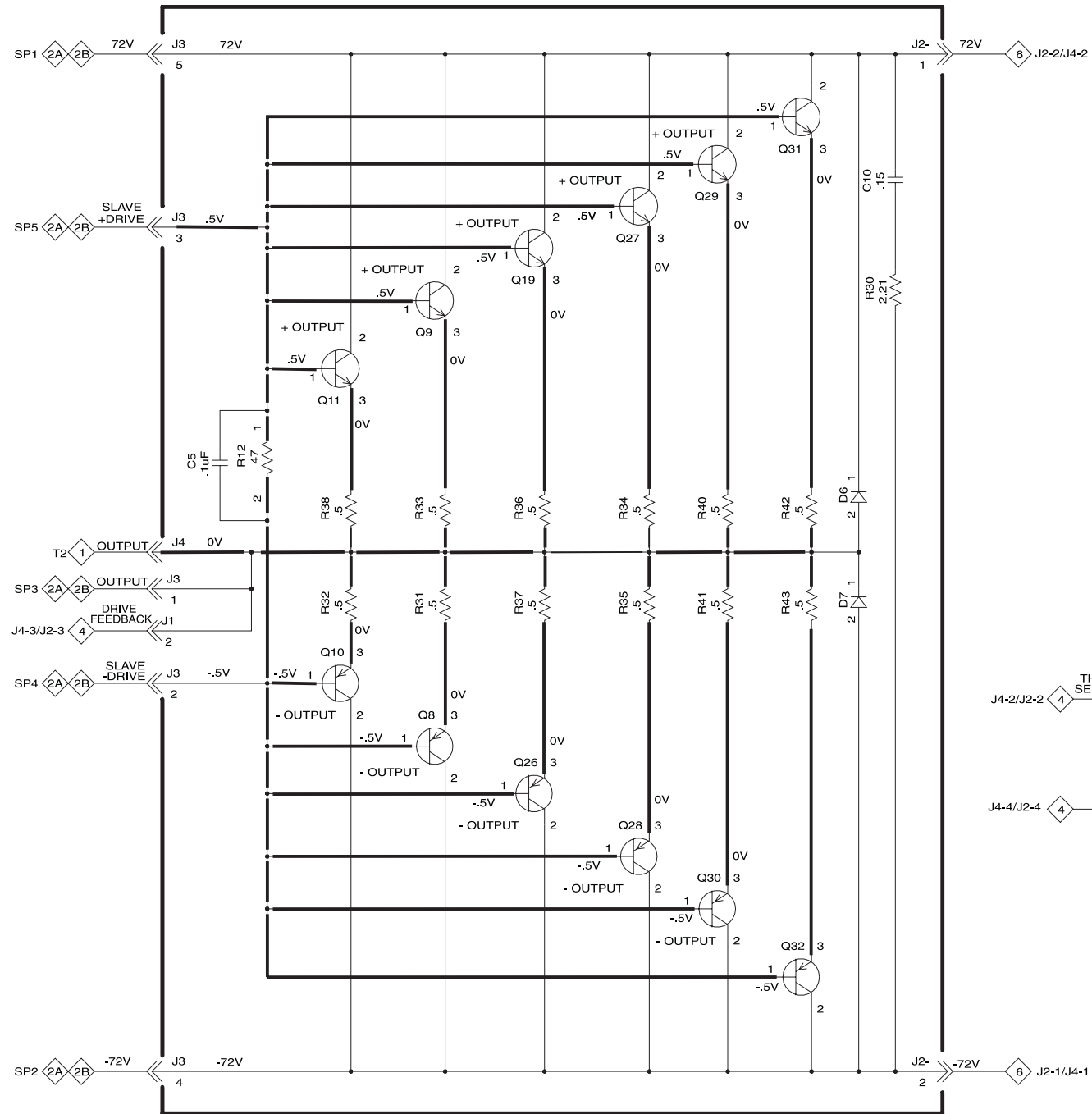



4 DRIVER 750760 SCH

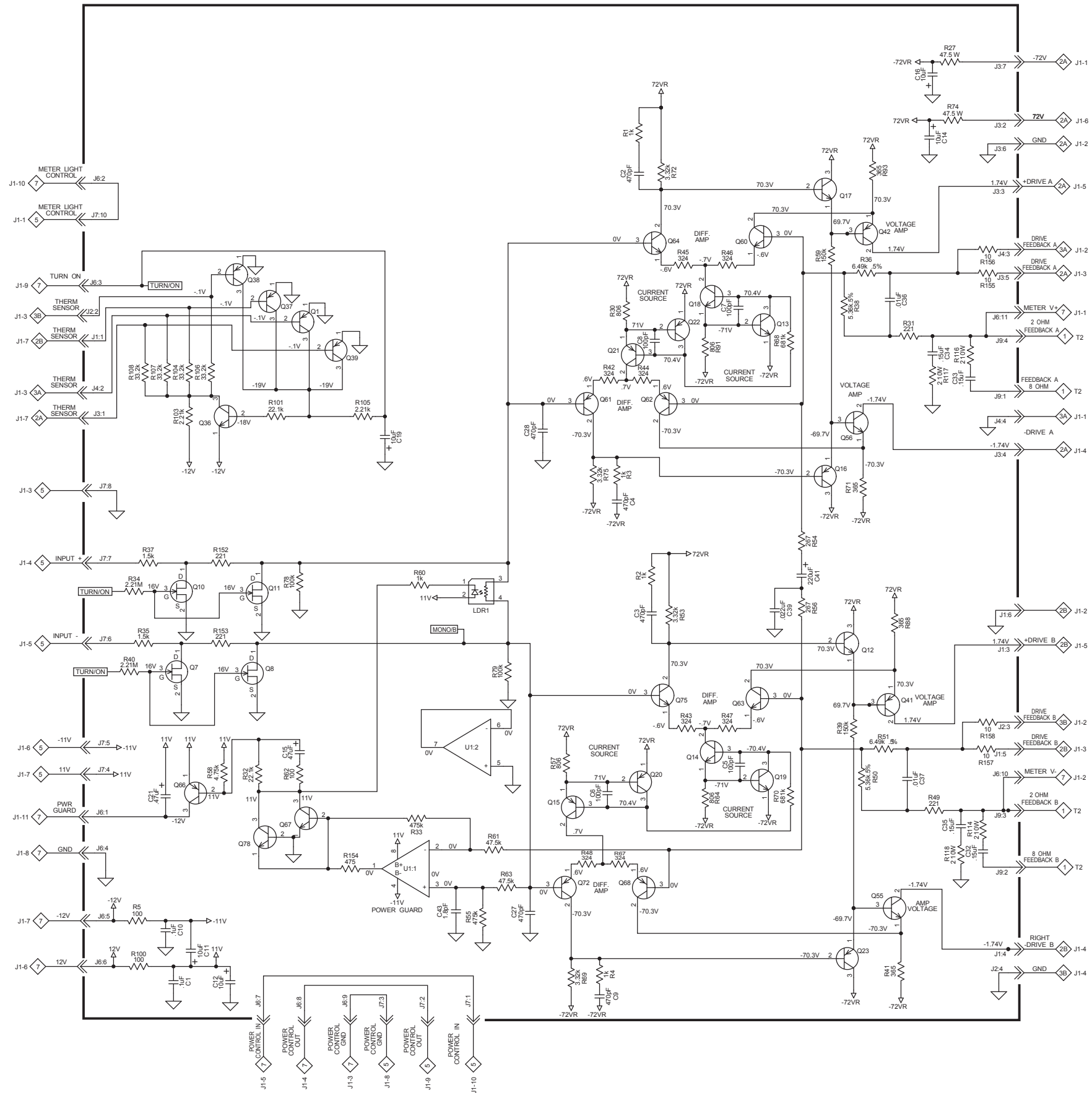

# 4 DRIVER 750760 PCB

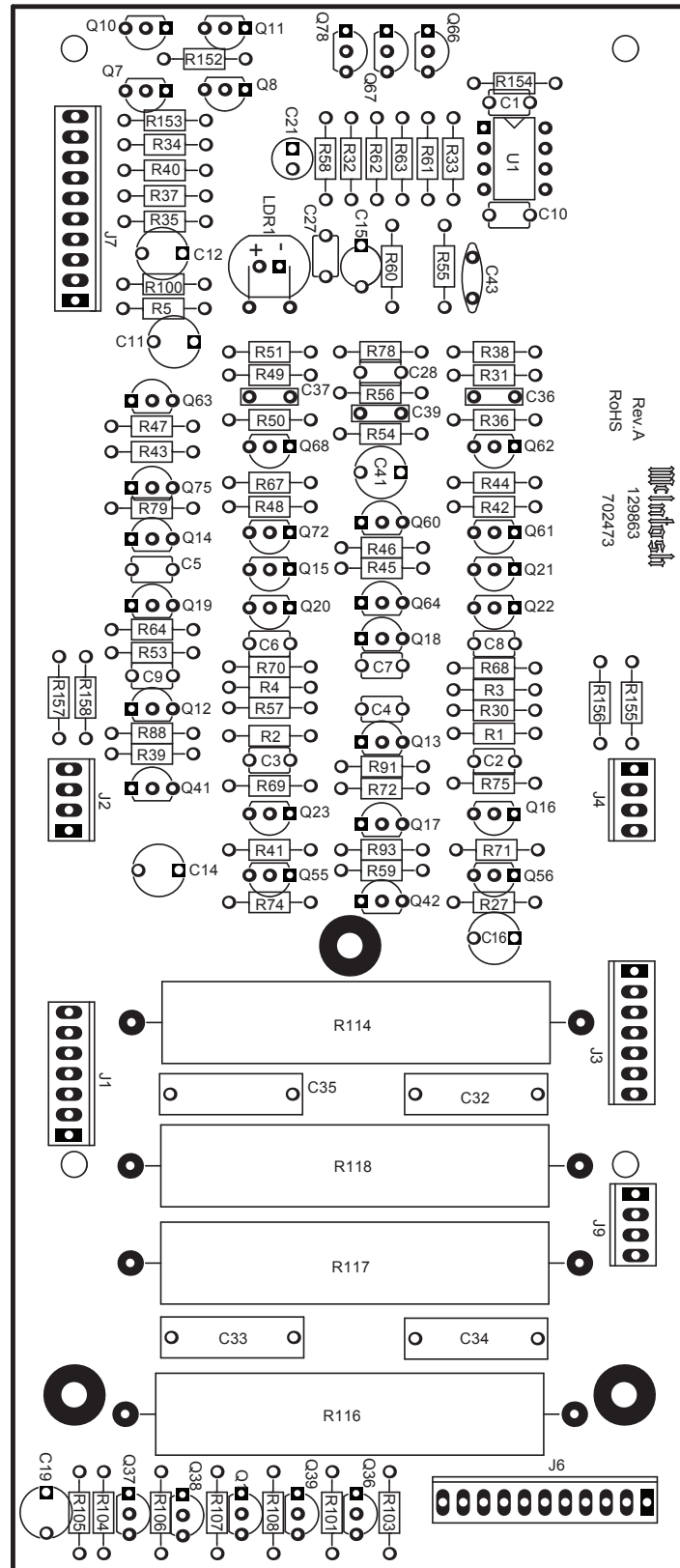

# 5 INPUT 750753 SCH and PCB

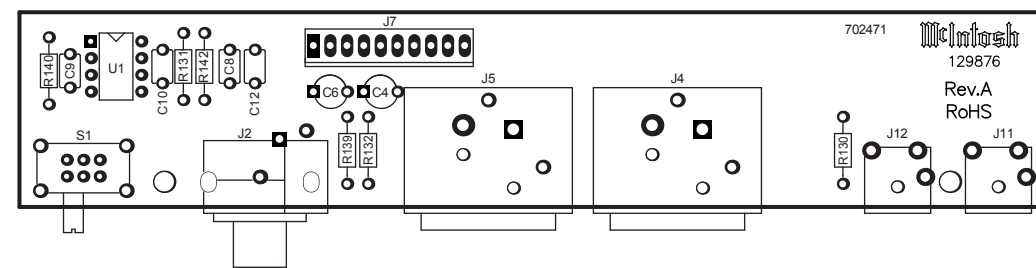
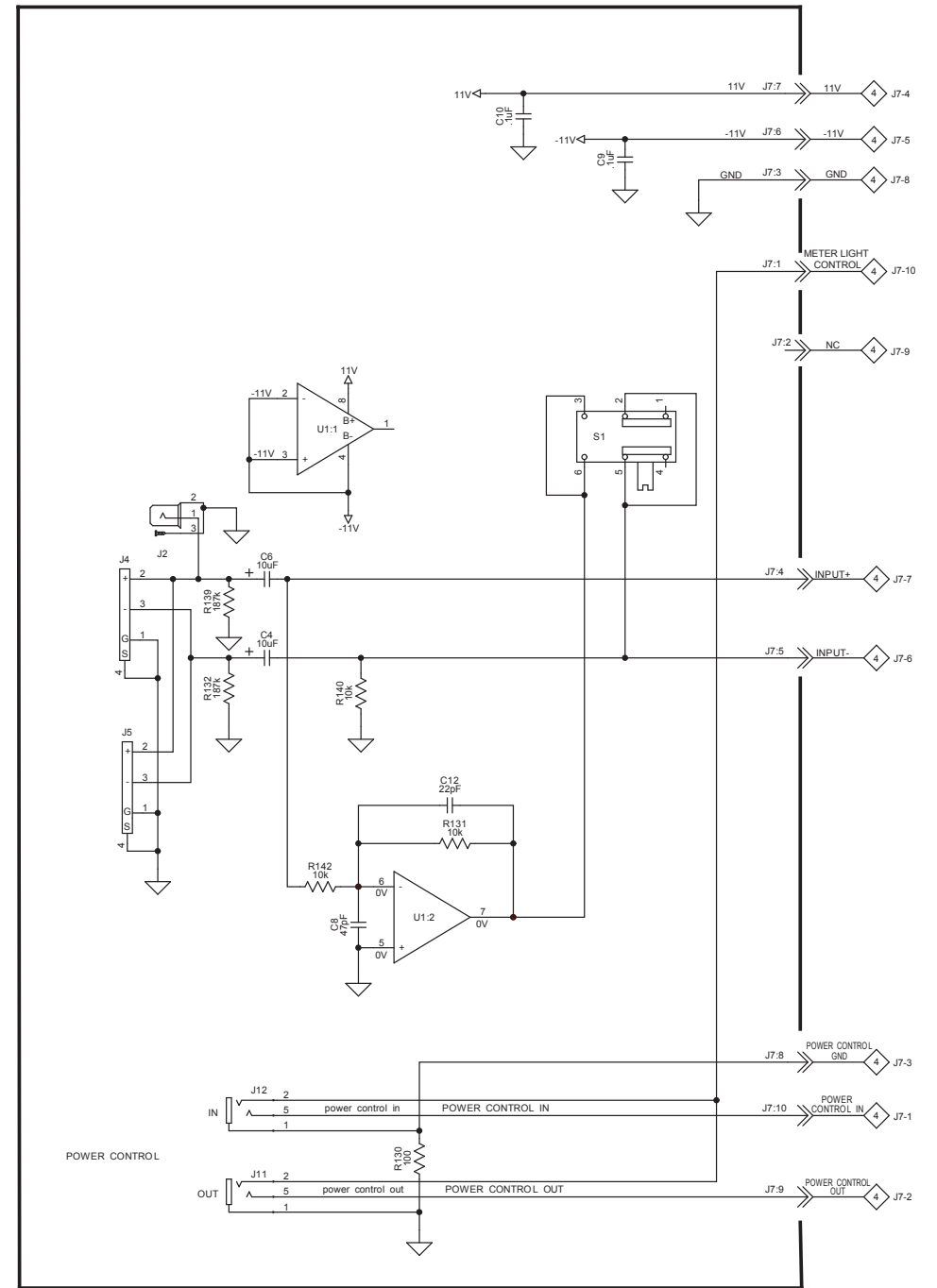

**6** CAPACITOR 749367 SCH and PCB

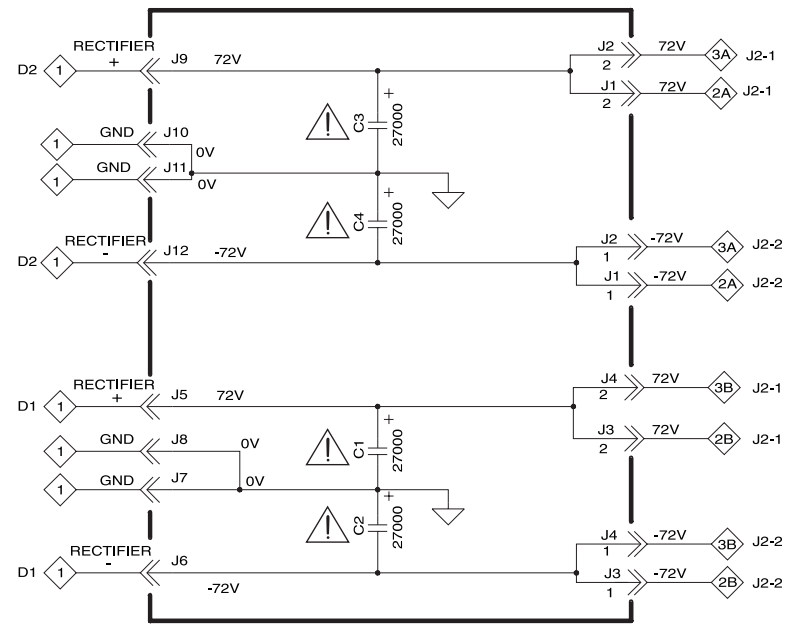

**!** WARNING Parts marked with a triangle and exclamation mark have critical characteristics. Use only replacement parts recommended by the manufacturer.

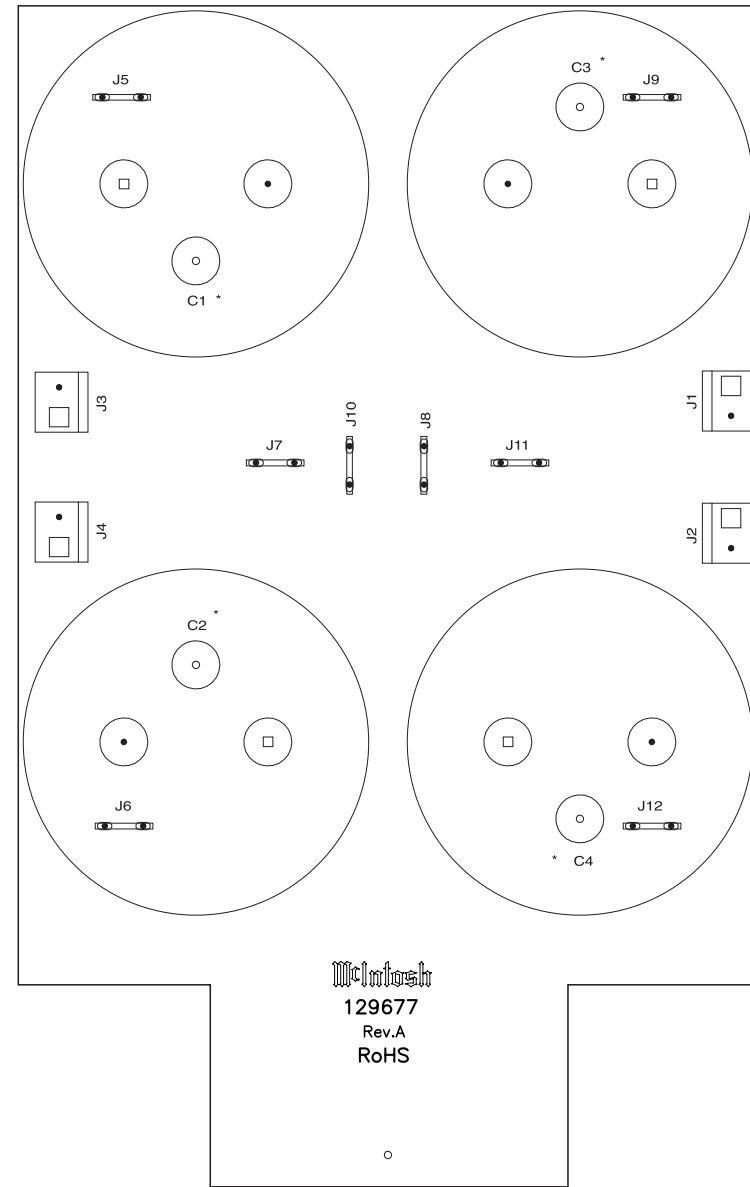

\* DENOTES COMPONENTS ON REVERSE OR FAR SIDE OF PCB

# 7 METER POWER SUPPLY 750752 SCH 1 of 2

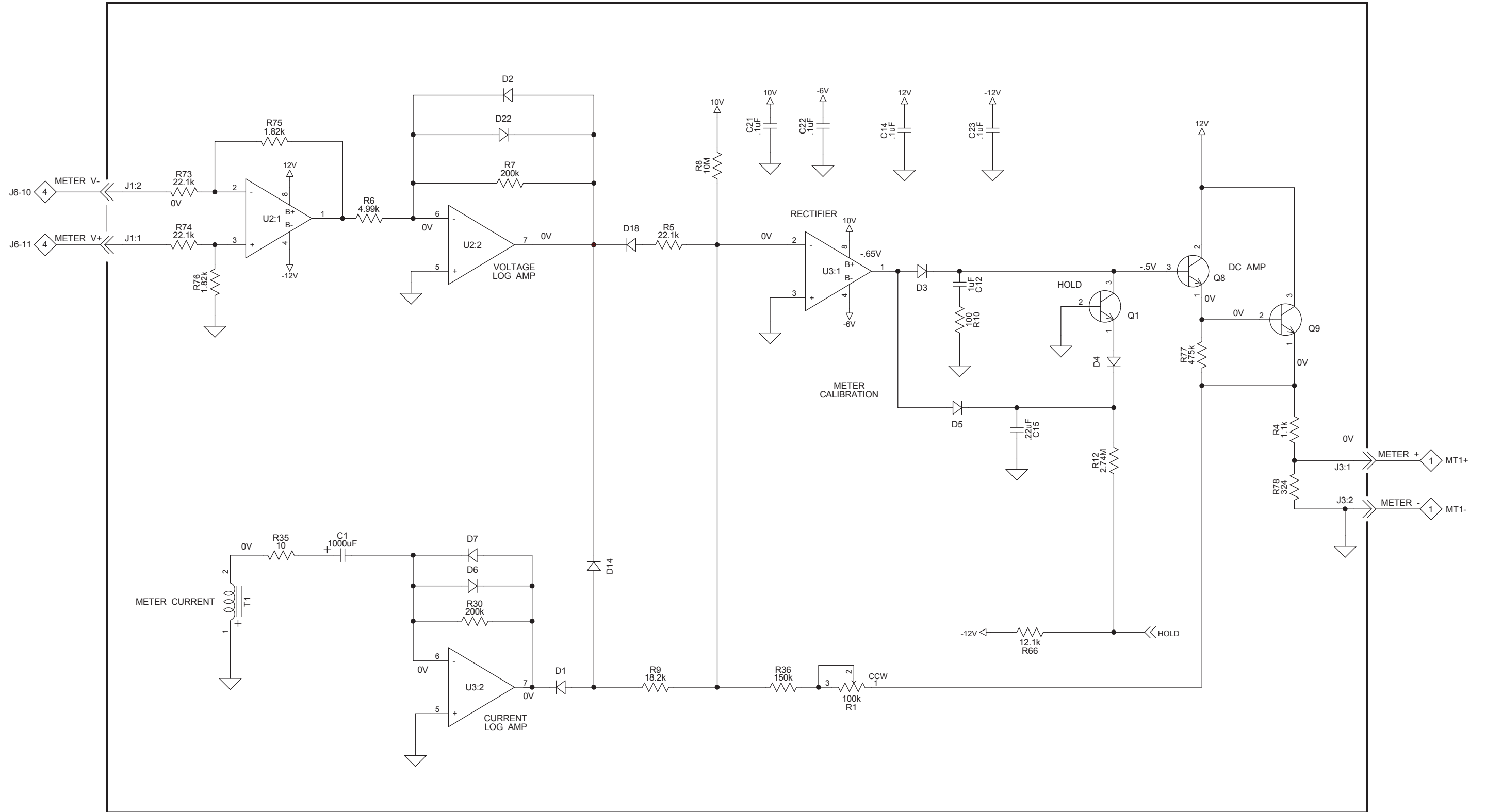

7 METER POWER SUPPLY 750752 SCH 2 of 2 and PCB

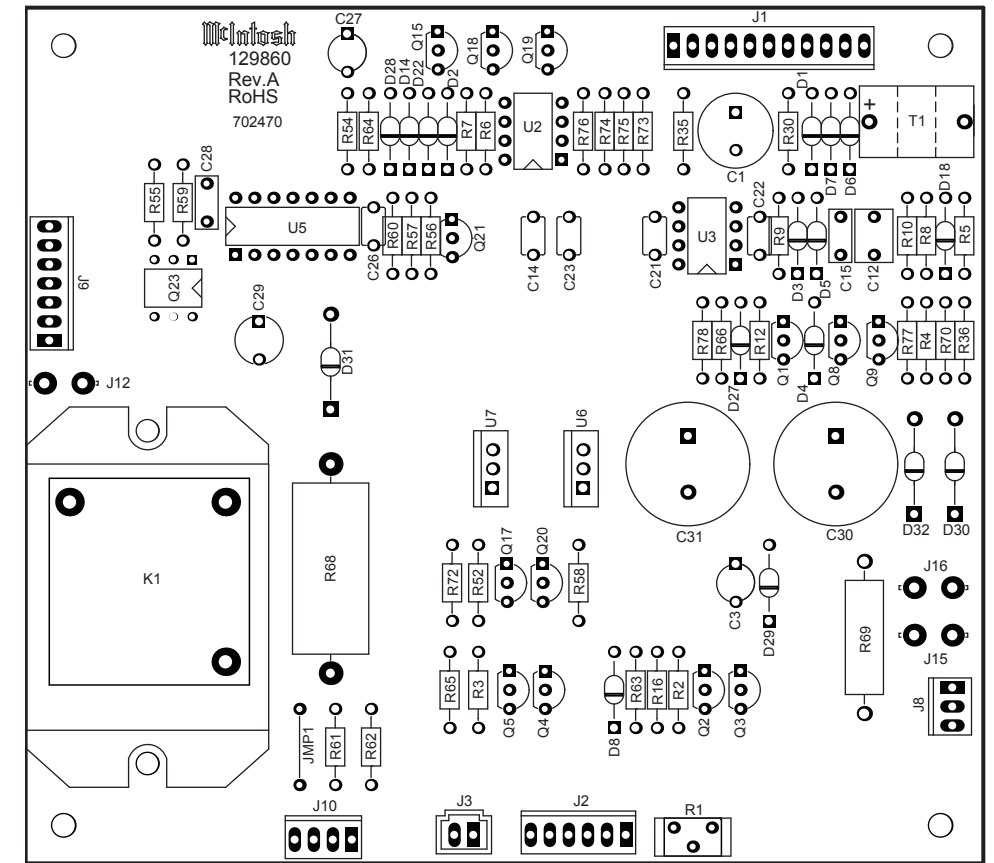
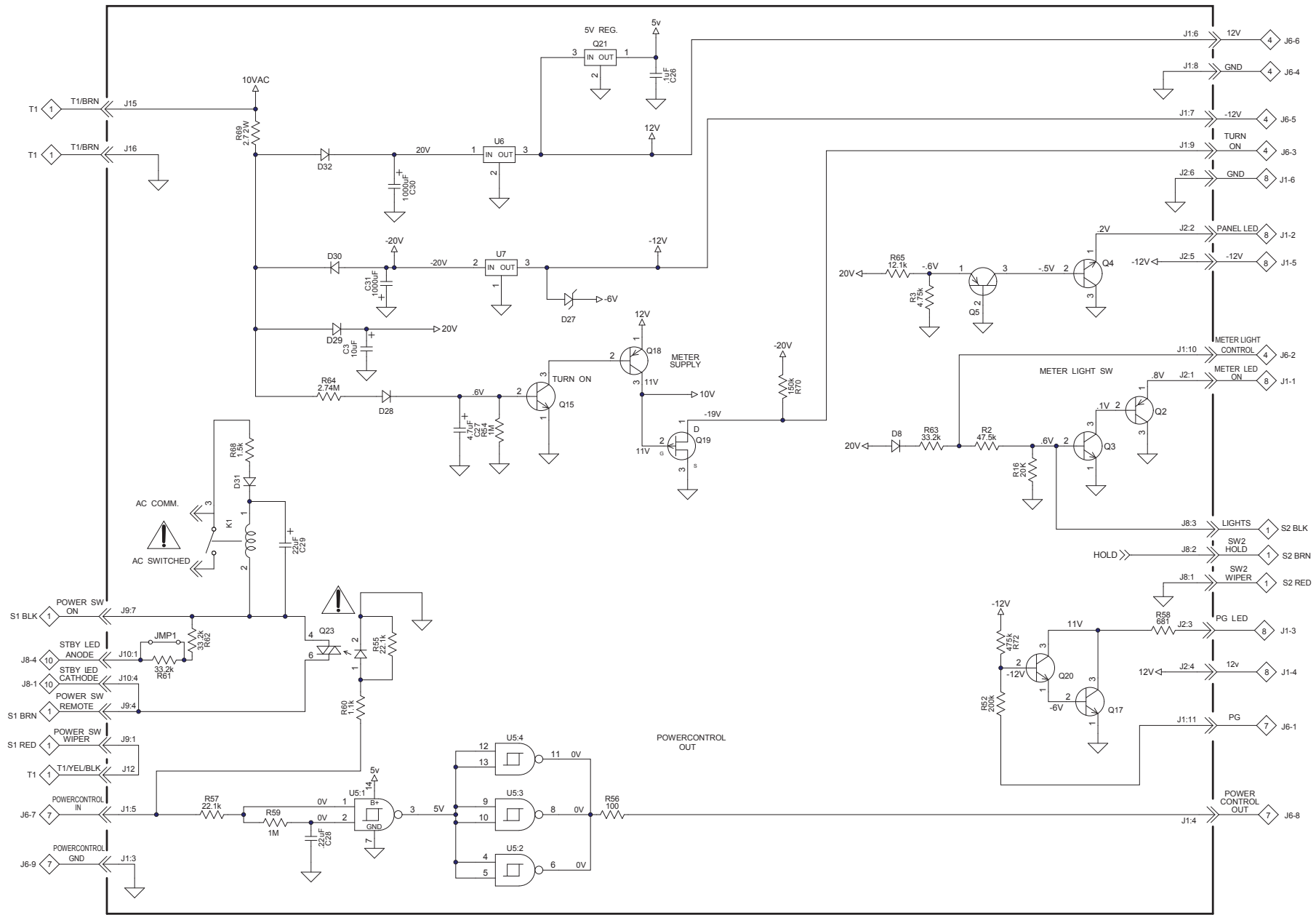

**!** WARNING Parts marked with a triangle and exclamation mark have critical characteristics. Use only replacement parts recommended by the manufacturer.

# 8 LAMP 750759 SCH and PCB

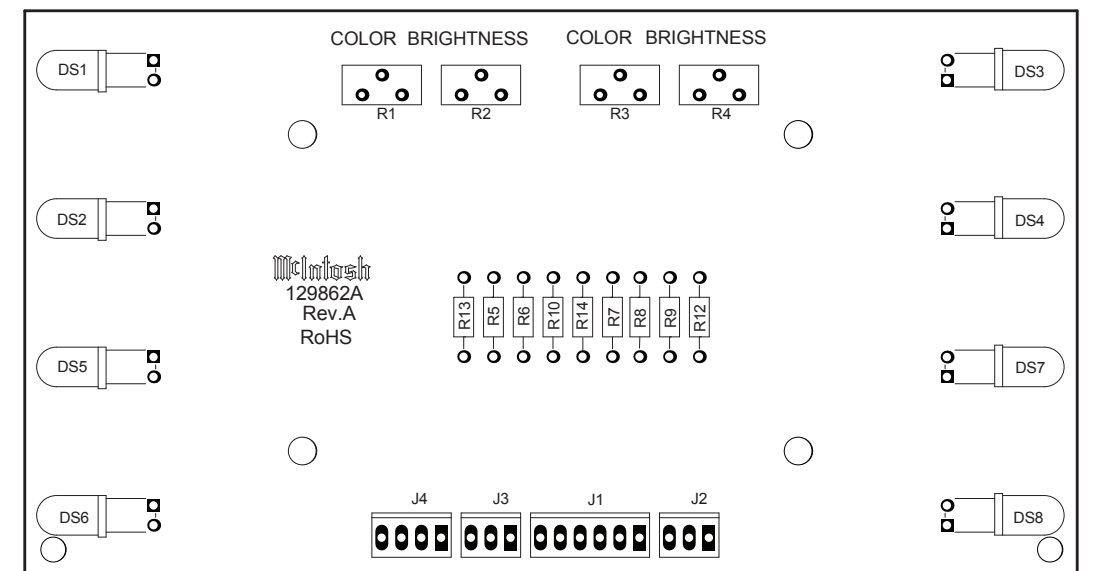
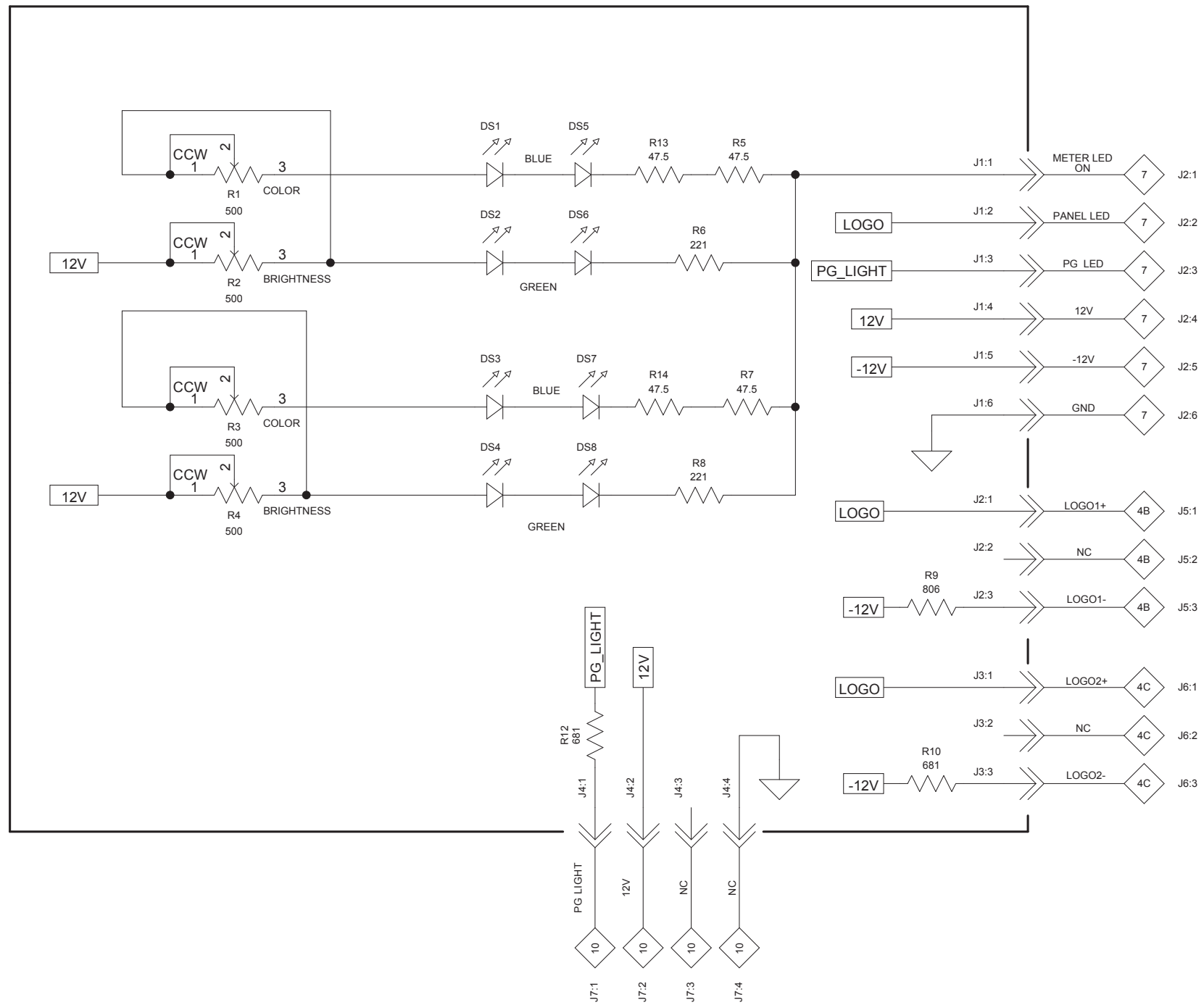

**9A** LIGHT 750759 SCH and PCB

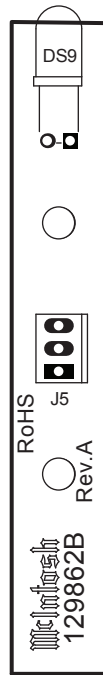
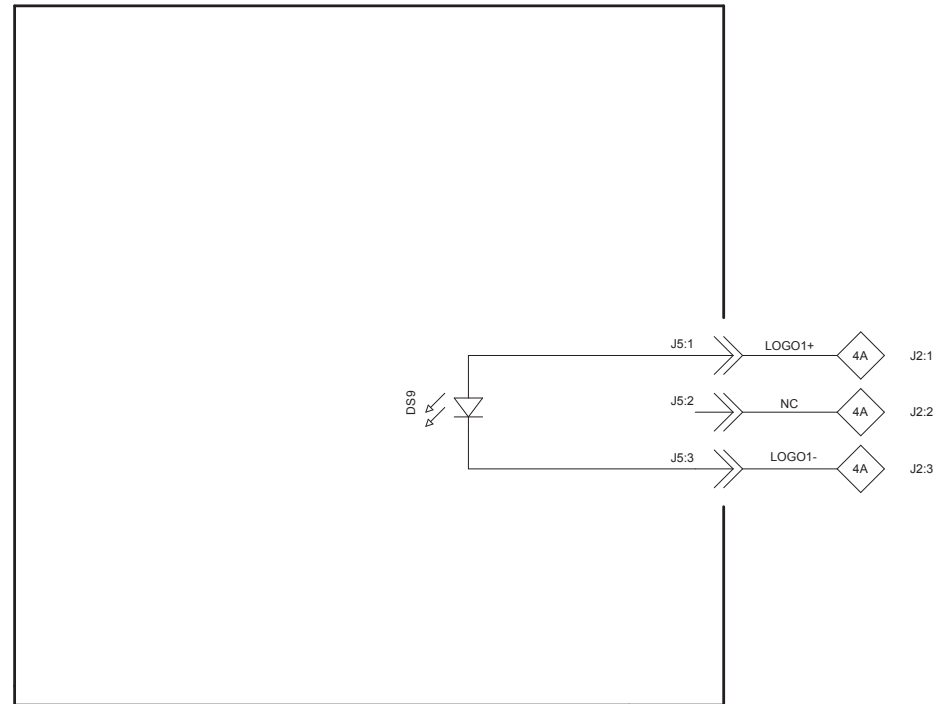

**10** POWER GUARD 750759 SCH and PCB

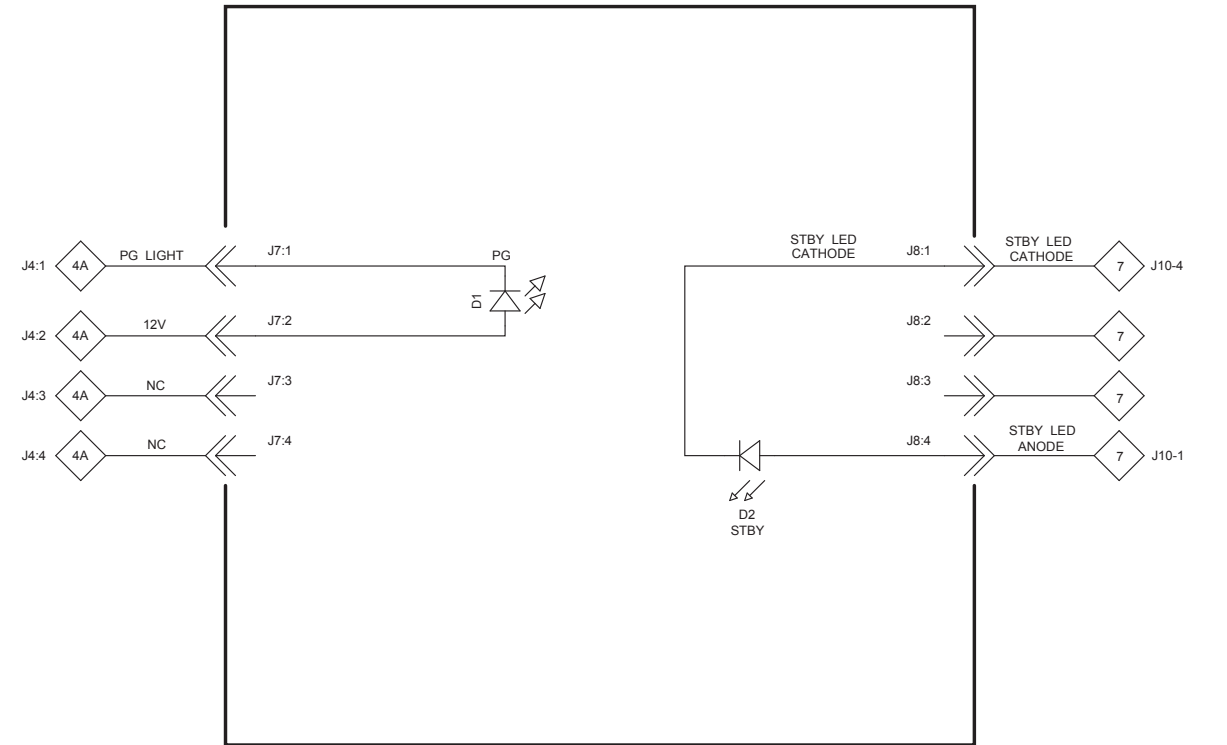

**9B** LIGHT 750759 SCH and PCB

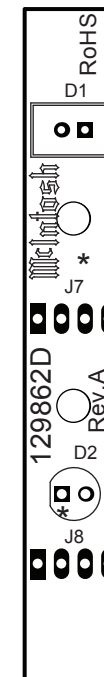
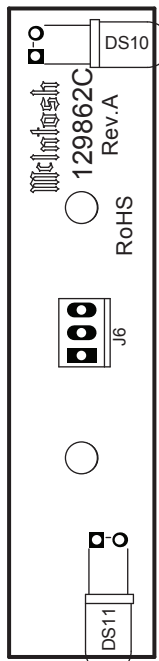
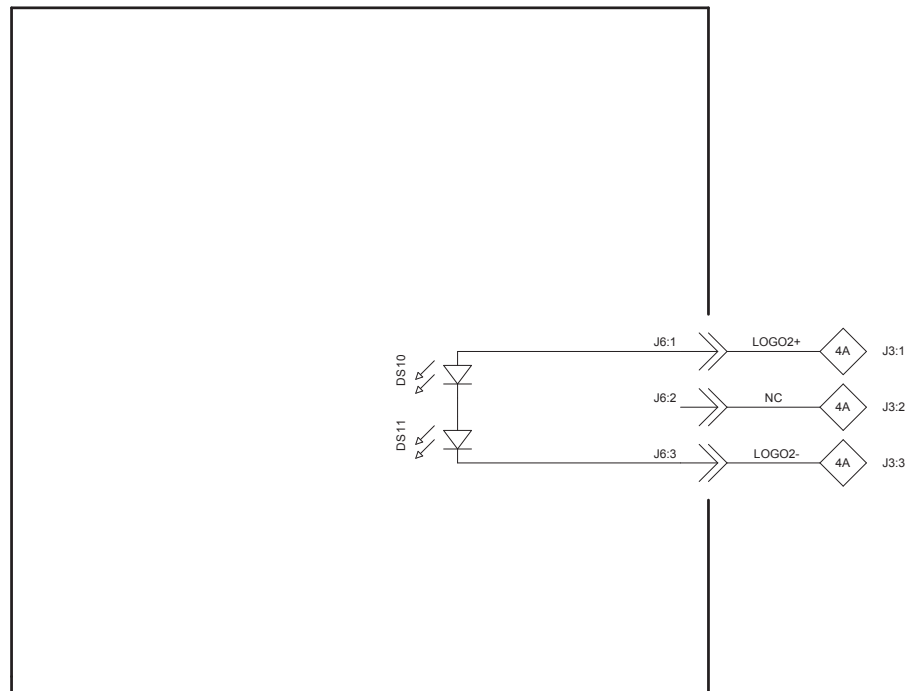

# *NOTES*



## PARTS LIST

## 1 INTERCONNECT

Ref. No.	Description	Part No.
C5	CAPACITOR ASSY	052005
C6	CAPACITOR ASSY	052005
CB1	CIRCUIT BREAKER 20A (100-120V)	088022
CB1	CIRCUIT BREAKER 10A (220-240V)	088023
D1	DIODE BRIDGE RECTIFIER	070181
D2	DIODE BRIDGE RECTIFIER	070181
MT1	METER	124105
RT1	THERMISTOR ASSY	052017
RT2	THERMISTOR ASSY	052017
S1	SWITCH POWER	146243
S2	SWITCH POWER	146243
T1	POWER TRANSFORMER	750754
T2	OUTPUT TRANSFORMER, POTTED	750755
TB1	AC TERMINAL BLOCK	074091

## 2 749485 HEATSINK MASTER PCB

C1	CAP ELECT 47UF 35V	066446
C2	CAP ELECT 47UF 35V	066446
C3	CAP MONO .1UF 50V 20% Z5U	061346
C5	CAP MONO .1UF 50V 20% Z5U	061346
C7	CAP MONO 100PF 100V 10% NPO	061341
C8	CAP MONO 100PF 100V 10% NPO	061341
C9	CAP MONO .01UF 50V 20% X7R	061345
C10	CAP POLYPROP 0.15UF 10% 250VDC	064363
C16	CAP MONO .01UF 50V 20% X7R	061345
D1	DIODE SILICON	070174
D2	DIODE SILICON	070174
D3	DIODE SILICON	070174
D4	DIODE SILICON	070174
D5	DIODE SILICON	070174
D6	DIODE 200V 6A	070133
D7	DIODE 200V 6A	070133
J1	CONN MALE 7 PIN	117217
J2_	CONN HEADER 2 PIN 0.156	117404
J4_	BLADE FASTON W/FEET	117708
J4_	CONN 2 PIN MALE	117213
J5	BLADE FASTON .110	117712
L1	CHOKE RF 3.3UH 10%	122398
PCB1	PC BD HEATSINK	129770
Q1	TRANSISTOR NPN SILICON	132317
Q2	TRANSISTOR PNP SILICON	132304
Q3	TRANSISTOR NPN	132310
Q4	TRANSISTOR PNP	132311
Q6	TRANSISTOR NPN	132325
Q7	TRANSISTOR PNP	132326
Q8	TRANSISTOR PNP 200W 230V	132314
Q9	TRANSISTOR NPN 200W 230V	132313
Q10	TRANSISTOR PNP 200W 230V	132314
Q11	TRANSISTOR NPN 200W 230V	132313
Q19	TRANSISTOR NPN 200W 230V	132313
Q26	TRANSISTOR PNP 200W 230V	132314
Q27	TRANSISTOR NPN 200W 230V	132313
Q28	TRANSISTOR PNP 200W 230V	132314
Q29	TRANSISTOR NPN 200W 230V	132313
Q30	TRANSISTOR PNP 200W 230V	132314
Q31	TRANSISTOR NPN 200W 230V	132313
Q32	TRANSISTOR PNP 200W 230V	132314
R1	RES MF 365 OHM 1% 1/4W	144505

Ref. No.	Description	Part No.
R2	RES MET OX 680 OHM 5% 1/2W	137099
R3	RES MF 22.1K 1% 1/4W	144564
R6	RES MET OX 1.8K 5% 1/2W	137100
R7	RES MET OX 430 OHM 5% 1/2W	137101
R8	RES MF 365 OHM 1% 1/4W	144505
R9	RES MET OX 680 OHM 5% 1/2W	137099
R10	RES MF 22.1K 1% 1/4W	144564
R11	RES MET OX 1.8K 5% 1/2W	137100
R12	RES MET OX 47 OHM 5% 1/2W	137102
R13	POT TRIM 200 OHM 20% HORIZ AD	134506
R30	RES MF 2.21 OHM 1% 1/4W	144607
R31	RES WW .5 OHM 5% 5W	139255
R32	RES WW .5 OHM 5% 5W	139255
R33	RES WW .5 OHM 5% 5W	139255
R34	RES WW .5 OHM 5% 5W	139255
R35	RES WW .5 OHM 5% 5W	139255
R36	RES WW .5 OHM 5% 5W	139255
R37	RES WW .5 OHM 5% 5W	139255
R38	RES WW .5 OHM 5% 5W	139255
R40	RES WW .5 OHM 5% 5W	139255
R41	RES WW .5 OHM 5% 5W	139255
R42	RES WW .5 OHM 5% 5W	139255
R43	RES WW .5 OHM 5% 5W	139255
RT1	SENSOR THERMAL	144249
	CABLE ASSY HTSINK/HTSINK SLAVE	171717

## 3 749487 HEATSINK SLAVE PCB

C10	CAP POLYPROP 0.15UF 10% 250VDC	064363
D6	DIODE 200V 6A	070133
D7	DIODE 200V 6A	070133
	SLEEVE SIL FG VW-1 180 DEG #12	077073
J1	CONN 4 PIN	117215
J2	CONN HEADER 2 PIN 0.156	117404
J3	CONN MALE 5 PIN .156	117568
J4	BLADE FASTON W/FEET	117708
	PC BD HEATSINK SLAVE	129771
R12	RES MET OX 47 OHM 5% 1/2W	137102
R30	RES MF 2.21 OHM 1% 1/4W	144607
R31	RES WW .5 OHM 5% 5W	139255
R32	RES WW .5 OHM 5% 5W	139255
R33	RES WW .5 OHM 5% 5W	139255
R34	RES WW .5 OHM 5% 5W	139255
R35	RES WW .5 OHM 5% 5W	139255
R36	RES WW .5 OHM 5% 5W	139255
R37	RES WW .5 OHM 5% 5W	139255
R38	RES WW .5 OHM 5% 5W	139255
R40	RES WW .5 OHM 5% 5W	139255
R41	RES WW .5 OHM 5% 5W	139255
R42	RES WW .5 OHM 5% 5W	139255
R43	RES WW .5 OHM 5% 5W	139255
RT1	SENSOR THERMAL	144249
Q9	TRANSISTOR NPN 200W 230V	132313
Q10	TRANSISTOR PNP 200W 230V	132314
Q11	TRANSISTOR NPN 200W 230V	132313
Q19	TRANSISTOR NPN 200W 230V	132313
Q26	TRANSISTOR PNP 200W 230V	132314
Q27	TRANSISTOR NPN 200W 230V	132313
Q28	TRANSISTOR PNP 200W 230V	132314
Q29	TRANSISTOR NPN 200W 230V	132313
Q30	TRANSISTOR PNP 200W 230V	132314
Q31	TRANSISTOR NPN 200W 230V	132313
Q32	TRANSISTOR PNP 200W 230V	132314

# PARTS LIST con't

## 4 750760 DRIVER PCB

Ref. No.	Description	Part No.
C1	CAP MONO .1UF 50V 20%	061346
C2	CAP MONO 470PF 100V 5% NPO	061343
C3	CAP MONO 470PF 100V 5% NPO	061343
C4	CAP MONO 470PF 100V 5% NPO	061343
C5	CAP MONO 100PF 100V 10% NPO	061341
C6	CAP MONO 100PF 100V 10% NPO	061341
C7	CAP MONO 100PF 100V 10% NPO	061341
C8	CAP MONO 100PF 100V 10% NPO	061341
C9	CAP MONO 470PF 100V 5% NPO	061343
C10	CAP MONO .1UF 50V 20%	061346
C11	CAP ELECT 10UF 100VDC	066462
C12	CAP ELECT 10UF 100VDC	066462
C14	CAP ELECT 10UF 100VDC	066462
C15	CAP ELECT 47UF 35V	066446
C16	CAP ELECT 10UF 100VDC	066462
C19	CAP ELECT 10UF 100VDC	066462
C21	CAP ELECT .47UF 50V 20%	066244
C27	CAP MONO 470PF 100V 5% NPO	061343
C28	CAP MONO 470PF 100V 5% NPO	061343
C32	CAP POLYPROP 0.15UF 10% 250VDC	064464
C33	CAP POLYPROP 0.15UF 10% 250VDC	064464
C34	CAP POLYPROP 0.15UF 10% 250VDC	064464
C35	CAP POLYPROP 0.15UF 10% 250VDC	064464
C36	CAP MPF 0.01UF 5% 63VDC	064312
C37	CAP MPF 0.01UF 5% 63VDC	064312
C39	CAP MPF 0.022UF 5% 63VDC	064316
C43	CAP DISC 1.8PF+/- .25PF NPO	061356
C41	CAP ELECT 220UF 25V	066507
J1	CONN MALE 7 PIN	117217
J2	CONN 4 PIN	117215
J3	CONN MALE 7 PIN	117217
J4	CONN 4 PIN	117215
J6	CONN 11 POS MALE	117279
J7	CONN MALE 10 POS	117219
J9	CONN 4 PIN	117215
LDR1	LDR NETWORK	144179
PCB1	PC BD DRIVER	129863
Q1	TRANSISTOR PNP SILICON	132304
Q7	TRANSISTOR N JFET	132319
Q8	TRANSISTOR N JFET	132319
Q10	TRANSISTOR N JFET	132319
Q11	TRANSISTOR N JFET	132319
Q12	TRANSISTOR NPN SILICON	132317
Q13	TRANSISTOR NPN SILICON	132317
Q14	TRANSISTOR SI NPN	132254
Q15	TRANSISTOR PNP	132255
Q16	TRANSISTOR PNP SILICON	132304
Q17	TRANSISTOR NPN SILICON	132317
Q18	TRANSISTOR SI NPN	132254
Q19	TRANSISTOR NPN SILICON	132317
Q20	TRANSISTOR PNP SILICON	132304
Q21	TRANSISTOR PNP	132255
Q22	TRANSISTOR PNP SILICON	132304
Q23	TRANSISTOR PNP SILICON	132304
Q36	TRANSISTOR NPN SILICON	132317
Q37	TRANSISTOR PNP SILICON	132304
Q38	TRANSISTOR PNP SILICON	132304
Q39	TRANSISTOR PNP SILICON	132304

Ref. No.	Description	Part No.
Q41	TRANSISTOR PNP 2SA1321C	132326
Q42	TRANSISTOR PNP 2SA1321C	132326
Q55	TRANSISTOR NPN 2SC3334C	132325
Q56	TRANSISTOR NPN 2SC3334C	132325
Q60	TRANSISTOR SI NPN	132254
Q61	TRANSISTOR PNP	132255
Q62	TRANSISTOR PNP	132255
Q63	TRANSISTOR SI NPN	132254
Q64	TRANSISTOR SI NPN	132254
Q66	TRANSISTOR PNP SILICON	132304
Q67	TRANSISTOR NPN SILICON	132317
Q68	TRANSISTOR PNP	132255
Q72	TRANSISTOR PNP	132255
Q75	TRANSISTOR SI NPN	132254
Q78	TRANSISTOR NPN SILICON	132317
R1	RES MF 1K 1% 1/4W	144513
R2	RES MF 1K 1% 1/4W	144513
R3	RES MF 1K 1% 1/4W	144513
R4	RES MF 1K 1% 1/4W	144513
R5	RES MF 100 OHM 1% 1/4W	144568
R27	RES MET OX 47 OHM .5W 5%	137102
R30	RES MF 866 OHM 1% 1/4W	144503
R31	RES MF 221 OHM 1% 1/4W	144559
R32	RES MF 22.1K 1% 1/4W	144564
R33	RES MF 475K 1% 1/4W	144604
R34	RES MF 2.21M 1/4W	144576
R35	RES MF 1.5K 1% 1/4W	144539
R36	RES MF 6.49K .5% 1/4W	144617
R37	RES MF 1.5K 1% 1/4W	144539
R38	RES MF 5.36K .5% 1/4W	144615
R39	RES MF 150K 1% 1/4W	144627
R40	RES MF 2.21M 1/4W	144576
R41	RES MF 365 OHM 1% 1/4W	144505
R42	RES MF 324 OHM 1% 1/4W	144597
R43	RES MF 324 OHM 1% 1/4W	144597
R44	RES MF 324 OHM 1% 1/4W	144597
R45	RES MF 324 OHM 1% 1/4W	144597
R46	RES MF 324 OHM 1% 1/4W	144597
R47	RES MF 324 OHM 1% 1/4W	144597
R48	RES MF 324 OHM 1% 1/4W	144597
R49	RES MF 221 OHM 1% 1/4W	144559
R50	RES MF 5.36K .5% 1/4W	144615
R51	RES MF 6.49K .5% 1/4W	144617
R53	RES MF 3.32K 1% 1/4W	144518
R54	RES MF 267 OHM 1% 1/4W	144560
R55	RES MF 475K 1% 1/4W	144604
R56	RES MF 267 OHM 1% 1/4W	144560
R57	RES MF 866 OHM 1% 1/4W	144503
R58	RES MF 4.75K 1% 1/4W	144520
R59	RES MF 150K 1% 1/4W	144627
R60	RES MF 1K 1% 1/4W	144513
R61	RES MF 47.5K 1% 1/4W	144526
R62	RES MF 100 OHM 1% 1/4W	144568
R63	RES MF 47.5K 1% 1/4W	144526
R64	RES MF 866 OHM 1% 1/4W	144503
R67	RES MF 324 OHM 1% 1/4W	144597
R68	RES MF 681K 1% 1/4W	144643
R69	RES MF 3.32K 1% 1/4W	144518
R70	RES MF 681K 1% 1/4W	144643
R71	RES MF 365 OHM 1% 1/4W	144505
R72	RES MF 3.32K 1% 1/4W	144518
R74	RES MET OX 47 OHM .5W 5%	137102

# PARTS LIST con't

**4 750760 DRIVER PCB Con't**

Ref. No.	Description	Part No.
R75	RES MF 3.32K 1% 1/4W	144518
R78	RES MF 100K 1% 1/4W	144528
R79	RES MF 100K 1% 1/4W	144528
R88	RES MF 365 OHM 1% 1/4W	144505
R91	RES MF 866 OHM 1% 1/4W	144503
R93	RES MF 365 OHM 1% 1/4W	144505
R100	RES MF 100 OHM 1% 1/4W	144568
R101	RES MF 22.1K 1% 1/4W	144564
R103	RES MF 2.21K 1% 1/4W	144584
R104	RES MF 33.2K 1% 1/4W	144694
R105	RES MF 2.21K 1% 1/4W	144584
R106	RES MF 33.2K 1% 1/4W	144694
R107	RES MF 33.2K 1% 1/4W	144694
R108	RES MF 33.2K 1% 1/4W	144694
R114	RES WW 2 OHM 5% 10W	139257
R116	RES WW 2 OHM 5% 10W	139257
R117	RES WW 2 OHM 5% 10W	139257
R118	RES WW 2 OHM 5% 10W	139257
R152	RES MF 221 OHM 1% 1/4W	144559
R153	RES MF 221 OHM 1% 1/4W	144559
R154	RES MF 475 OHM 1% 1/4W	144509
R155	RES MF 10 OHM 1% 1/4W	144553
R156	RES MF 10 OHM 1% 1/4W	144553
R157	RES MF 10 OHM 1% 1/4W	144553
R158	RES MF 10 OHM 1% 1/4W	144553
U1	IC DUAL AMP	133259

**5 750753 INPUT PCB**

C4	CAP ELECT 10UF 50V	066445
C6	CAP ELECT 10UF 50V	066445
C8	CAP MONO 47PF 200V 10% NPO	061340
C9	CAP MONO .1UF 50V 20%	061346
C10	CAP MONO .1UF 50V 20%	061346
C12	CAP MONO 22PF 200V 10% NPO	061339
	TAPE DOUBLE SIDED 1/2	094192
	ADHESIVE HOT MELT	098249
J2	JACK RCA 1P RED	117706
J4	CONN XLR FEMALE HORIZ PCB LATCH	117814
J5	CONN XLR FEMALE HORIZ PCB LATCH	117814
J7	CONN MALE 10 POS	117219
J11	JACK HEADPHONE STEREO 1/8IN	117945
J12	JACK HEADPHONE STEREO 1/8IN	117945
PCB1	PCB INPUT	129876
U1	IC DUAL OPERATIONAL AMPLIFIER	133578
R130	RES MF 100 OHM 1% 1/4W	144568
R131	RES MF 10K 1% 1/4W	144504
R132	RES MF 187K 1% 1/4W	144621
R139	RES MF 187K 1% 1/4W	144621
R140	RES MF 10K 1% 1/4W	144504
R142	RES MF 10K 1% 1/4W	144504
S1	SWITCH SLIDE DPDT	148076

**6 749367 CAPACITOR PCB**

C1	CAPACITOR PCB CARD MOUNTING	066489
C2	CAPACITOR PCB CARD MOUNTING	066489
C3	CAPACITOR PCB CARD MOUNTING	066489
C4	CAPACITOR PCB CARD MOUNTING	066489
GP1	BRACKET PCB CARD MOUNTING	003611
GP1	BRACKET PCB CARD MOUNTING	003611

Ref. No.	Description	Part No.
J1	CONN HEADER 2 PIN 0.156	117404
J2	CONN HEADER 2 PIN 0.156	117404
J3	CONN HEADER 2 PIN 0.156	117404
J4	CONN HEADER 2 PIN 0.156	117404
J5	BLADE FASTON W/FEET	117708
J6	BLADE FASTON W/FEET	117708
J7	BLADE FASTON W/FEET	117708
J8	BLADE FASTON W/FEET	117708
J9	BLADE FASTON W/FEET	117708
J10	BLADE FASTON W/FEET	117708
J11	BLADE FASTON W/FEET	117708
J12	BLADE FASTON W/FEET	117708
	PC BD CAPACITOR	129677
	SCR TT 6-32 X 1/4 PH PN BLK	401054

**7 750752 METER POWER SUPPLY PCB**

C1	CAP ELECT 1000UF 25V	066513
C3	CAP ELECT 10UF 50V	066445
C12	CAP MPF 1UF 5% 63VDC	064337
C14	CAP MONO .1UF 50V 20% Z5U	061346
C15	CAP MPF 0.22UF 5% 63VDC	064329
C21	CAP MONO .1UF 50V 20% Z5U	061346
C22	CAP MONO .1UF 50V 20% Z5U	061346
C23	CAP MONO .1UF 50V 20% Z5U	061346
C26	CAP MONO .1UF 50V 20% Z5U	061346
C28	CAP MPF 0.22UF 5% 63VDC	064329
C27	CAP ELECT 4.7UF 50V	066512
C29	CAP ELECT 22UF 100V	066574
C30	CAP ELECT 1000UF 20% 35V	066566
C31	CAP ELECT 1000UF 20% 35V	066566
D1	DIODE SILICON	070174
D2	DIODE SILICON	070174
D3	DIODE SILICON	070174
D4	DIODE SILICON	070174
D5	DIODE SILICON	070174
D6	DIODE SILICON	070174
D7	DIODE SILICON	070174
D8	DIODE SILICON	070174
D14	DIODE SILICON	070174
D18	DIODE SILICON	070174
D22	DIODE SILICON	070174
D27	DIODE ZENER 6.2V 5% 500MW	070184
D28	DIODE SILICON	070174
D29	DIODE SILICON	070174
D30	DIODE RECTIFIER	070175
D31	DIODE RECTIFIER	070175
D32	DIODE RECTIFIER	070175
J2	CONN MALE 6 POS FRICTION LOCK	117218
J3	HEADER 2 PIN LATCHING	117766
J8	CONN 3 POS MALE MTS100 NORMAL	117214
J9	CONN MALE 7 PIN	117217
J10	CONN 4 PIN	117215
J10	CONN 11 POS MALE	117279
J12	BLADE FASTON W/FEET	117708
J15	BLADE FASTON W/FEET	117708
J16	BLADE FASTON W/FEET	117708
K1	RELAY 48VDC	087049
PCB1	PC BD METER/PWR SUPPLY	129860
Q1	TRANSISTOR NPN SILICON	132317
Q2	TRANSISTOR PNP SILICON	132304
Q3	TRANSISTOR NPN SILICON	132317
Q4	TRANSISTOR NPN SILICON	132317

# PARTS LIST con't

## 7 750752 METER POWER SUPPLY PCB Con't

Ref. No.	Description	Part No.
Q5	TRANSISTOR PNP SILICON	132304
Q8	TRANSISTOR PNP	132254
Q9	TRANSISTOR NPN DAR	132303
Q15	TRANSISTOR NPN SILICON	132317
Q17	TRANSISTOR NPN SILICON	132317
Q18	TRANSISTOR PNP SILICON	132304
Q19	TRANSISTOR P CHAN JUNCTION FET	132320
Q20	TRANSISTOR NPN SILICON	132317
Q21	IC REGULATOR +5V	133568
Q23	TRIAC OPTOCOUPLER	131024
R1	POT TRIM 100K OHM 20%	134504
R2	RES MF 47.5K 1% 1/4W	144526
R3	RES MF 4.75K 1% 1/4W	144520
R4	RES MF 806 1% 1/4W	144512
R5	RES MF 22.1K 1% 1/4W	144564
R6	RES MF 4.99K 1% 1/4W	144521
R7	RES MF 200K 1% 1/4W	144531
R8	RES MF 10 OHM 1% 1/4W	144553
R9	RES MF 18.2K 1% 1/4W	144563
R10	RES MF 100 OHM 1% 1/4W	144568
R12	RES MF 2.74M 1% 1/4W	144578
R16	RES MF 20K 1% 1/4W	144524
R30	RES MF 200K 1% 1/4W	144531
R35	RES MF 10M 1% 1/4W	144575
R36	RES MF 150K 1% 1/4W	144627
R52	RES MF 200K 1% 1/4W	144531
R54	RES MF 1M 1% 1/4W	144577
R55	RES MF 22.1K 1% 1/4W	144564
R56	RES MF 100 OHM 1% 1/4W	144568
R57	RES MF 22.1K 1% 1/4W	144564
R58	RES MF 681 OHM 1% 1/4W	144567
R59	RES MF 1M 1% 1/4W	144577
R60	RES MF 1.1K 1% 1/4W	144514
R61	RES MF 33.2K 1% 1/4W	144694
R62	RES MF 33.2K 1% 1/4W	144694
R63	RES MF 33.2K 1% 1/4W	144694
R64	RES MF 2.74M 1% 1/4W	144578
R65	RES MF 12.1K 1% 1/4W	144550
R66	RES MF 12.1K 1% 1/4W	144550
R68	RES WW 1.5K 5% 5W	139247
R69	RES WW 2.7 OHM 2W 5% FP	139263
R70	RES MF 150K 1% 1/4W	144627
R72	RES MF 475K 1% 1/4W	144604
R73	RES MF 22.1K 1% 1/4W	144564
R74	RES MF 22.1K 1% 1/4W	144564
R75	RES MF 1.82K 1% 1/4W	144582

Ref. No.	Description	Part No.
R76	RES MF 1.82K 1% 1/4W	144582
R77	RES MF 475K 1% 1/4W	144604
R78	RES MF 324 OHM 1% 1/4W	144597
T1	TRANSFORMER CURRENT SCR TT 6-32 X 1/4 PH PN BLK	159353 401054
U2	IC DUAL OPERATIONAL AMPLIFIER	133578
U3	IC DUAL OPERATIONAL AMPLIFIER	133578
U5	IC NAND SCHMIT 2-IN X 4	133595
U6	IC REGULATOR 12V	133590
U7	IC REGULATOR -12V	133574

## 8 750759 LIGHT/LAMP/POWER GUARD PCB

Ref. No.	Description	Part No.
D1	LED AMBER	058133
D2	LED RED HIGH EFFICIENCY	058148
DS1	LED BLUE 5MM 30 DEG	058191
DS2	LED GREEN 5MM 30 DEG	058190
DS3	LED BLUE 5MM 30 DEG	058191
DS4	LED GREEN 5MM 30 DEG	058190
DS5	LED BLUE 5MM 30 DEG	058191
DS6	LED GREEN 5MM 30 DEG	058190
DS7	LED BLUE 5MM 30 DEG	058191
DS8	LED GREEN 5MM 30 DEG	058190
DS9	LED GREEN 5MM 30 DEG	058190
(DS9)	SPACER LED	112108
DS10	LED GREEN 5MM 30 DEG	058190
(DS10)	SPACER LED	112108
DS11	LED GREEN 5MM 30 DEG	058190
(DS11)	SPACER LED	112108
J1	CONN MALE 6 POS FRICTION LOCK	117218
J2	CONN 3 POS MALE MTS100 NORMAL	117214
J3	CONN 3 POS MALE MTS100 NORMAL	117214
J4	CONN 4 PIN	117215
J5	CONN 3 POS MALE MTS100 NORMAL	117214
J6	CONN 3 POS MALE MTS100 NORMAL	117214
J7	CONN 4 PIN	117215
J8	CONN 4 PIN	117215
PCB1	PC BD LED	129862
R1	POT TRIM 500 OHM 10% HORIZ ADJ	134508
R2	POT TRIM 500 OHM 10% HORIZ ADJ	134508
R3	POT TRIM 500 OHM 10% HORIZ ADJ	134508
R4	POT TRIM 500 OHM 10% HORIZ ADJ	134508
R5	RES MF 47.5 OHM 1% 1/4W	144642
R6	RES MF 221 OHM 1% 1/4W	144559
R7	RES MF 47.5 OHM 1% 1/4W	144642
R8	RES MF 221 OHM 1% 1/4W	144559
R9	RES MF 806 OHM 1% 1/4W	144512
R10	RES MF 681 OHM 1% 1/4W	144567
R12	RES MF 681 OHM 1% 1/4W	144567
R13	RES MF 47.5 OHM 1% 1/4W	144642
R14	RES MF 47.5 OHM 1% 1/4W	144642

# REPACKING INSTRUCTIONS

In the event it is necessary to repack the amplifier for shipment, the unit must be packed exactly as shown below.

**IMPORTANT - The four feet must be attached to the bottom of the unit so they will locate in the four holes of the bottom foam pad. Failure to do this will result in shipping damage.**

**Tape top and bottom cartons together along four edges with 3 inch packaging tape.**

**Use banding straps to make sure box is held together securely.**

If a shipping carton or any of the interior parts are needed, please call or write the Customer Service Department of McIntosh Laboratory. Order parts from the accompanying list by part number.

Use the original shipping carton and interior parts only if they are in good serviceable condition.

Quantity	Part Number	Description
1	034105	Shipping carton top
1	034104	Shipping carton bottom
2	034349	Foam Pad (top and bottom)
3	034350	Foam Ring
4	400159	10-32 x 3/4 inch screw
4	018445	Feet

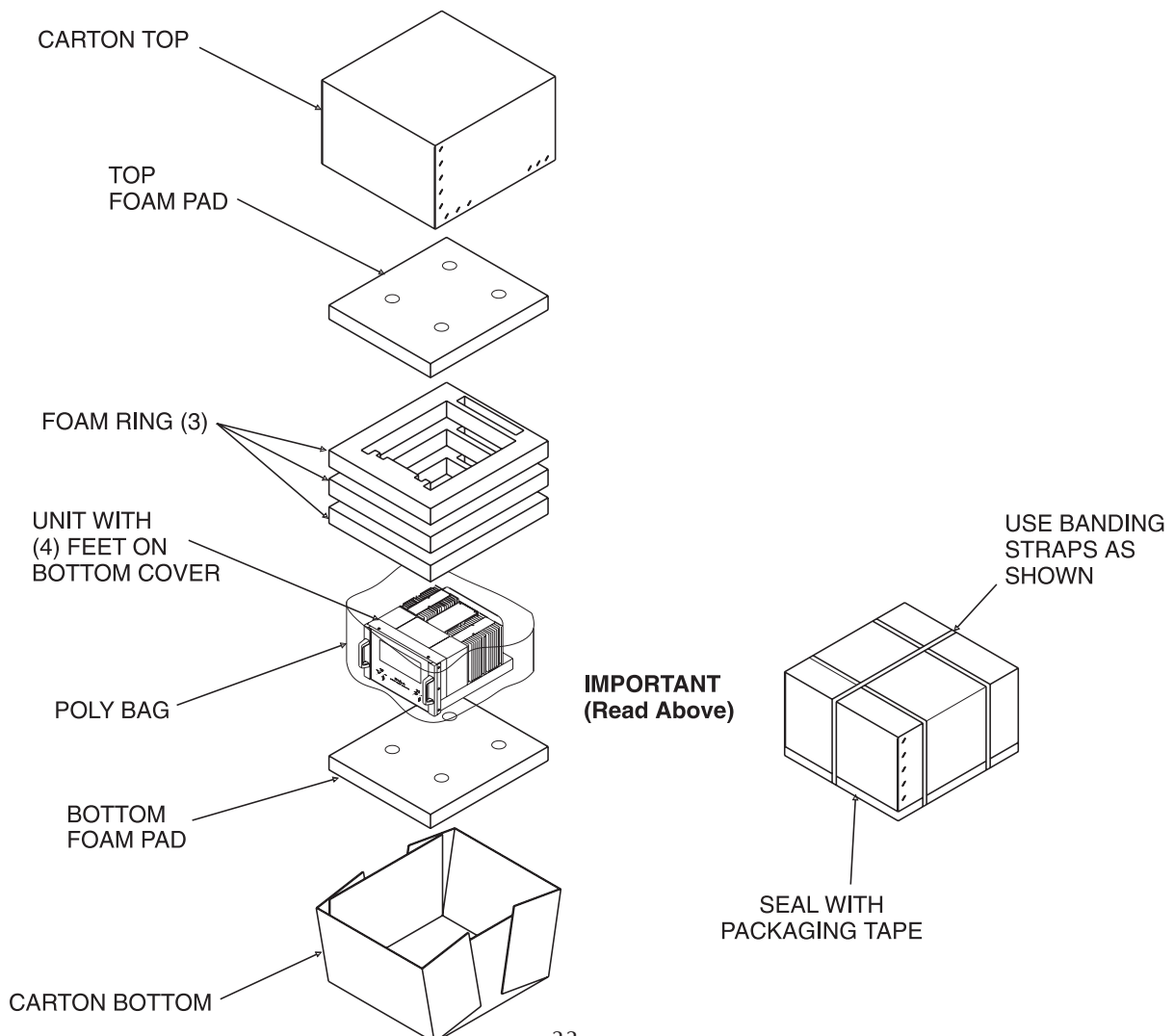

# MC1.2KW

## POWER AMPLIFIER

### SERVICE MANUAL

SERIAL NO. YF1001 And Above



The continuous improvement of its products is the policy of McIntosh Laboratory Incorporated, who reserve the right to improve design without notice. Because of the constant upgrading of McIntosh products' circuitry and components, the Company cannot insure, and does not warrant, the accuracy of the within schematic material, which is intended for information only.