

D.

DEFINITIVE TECHNOLOGY

BP9000 | SERIES

Owner's Manual

A90 Elevation Speaker Module

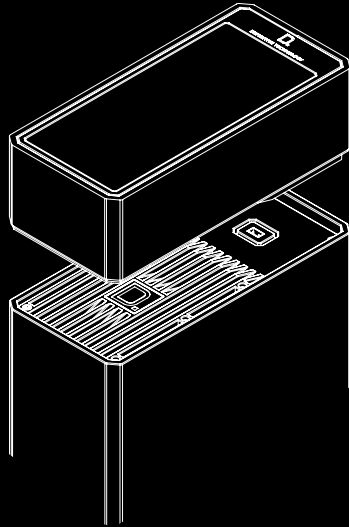
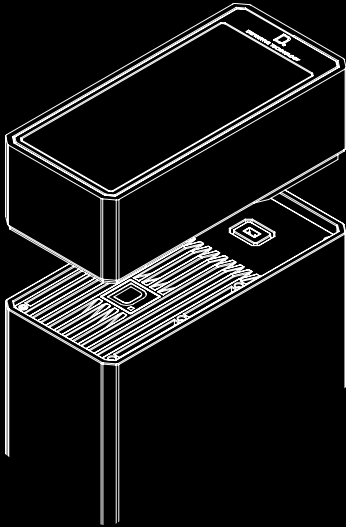

A90
Speaker Module

DEFINITIVE TECHNOLOGY

WHAT OBSESSION SOUNDS LIKE™

Thank you for choosing the Definitive Technology A90 height speaker module for your BP9000 loudspeakers. We created the A90 module as a dedicated height speaker designed specifically for the BP9060, BP9040, and BP9020 models so you can fully enjoy the Dolby Atmos® or DTS:X™ multi-dimensional sound experience within your home theater setup. The A90 easily connects and sits within the top of your BP9000 speakers to fire sound upwards, which is then reflected off the ceiling and back down to your viewing area.

Our engineers have spent many years in developing this product. In order to ensure that you experience the finest performance possible, we encourage you to take a moment to fully read this owner's manual and familiarize yourself with the proper installation and set-up procedures for your BP9000 speakers.

SAFETY PRECAUTIONS



CAUTION! To reduce the risk of electric shock and fire, do not remove the cover or back plate of this device. There are no user serviceable parts inside. Please refer all servicing to licensed service technicians.
Avis: Risque de choc électrique, ne pas ouvrir.

CAUTION! The international symbol of a lightning bolt inside of a triangle is intended to alert the user to uninsulated “dangerous voltage” within the device’s enclosure. The international symbol of an exclamation point inside of a triangle is intended to alert the user to the presence of important operating, maintenance and servicing information in the manual accompanying the device.

CAUTION! To prevent electrical shock, match wide blade of plug to wide slot, fully insert. Attention: Pour éviter les chocs électriques, introduire la lame la plus large de la fiche dans la borne correspondante de la prise et pousser jusqu’au fond.

CAUTION! To reduce the risk of electrical shock, do not expose this equipment to rain or moisture.

- 1. READ INSTRUCTIONS**—All safety and operating instructions should be read before operating the device.
- 2. RETAIN INSTRUCTIONS**—The safety and operating instructions should be retained for future reference.
- 3. HEED WARNINGS**—All warnings on the device and in the operating instructions should be adhered to.
- 4. FOLLOW INSTRUCTIONS**—All operating and safety instructions should be followed.
- 5. WATER & MOISTURE**—The device should never be used in, or near water for risk of fatal shock.
- 6. VENTILATION**—The device should always be located in such a way that it maintains proper ventilation. It should never be placed in a built-in installation or anywhere that may impede the flow of air through its heat sink.
- 7. HEAT**—Never locate the device near heat sources such as radiators, floor registers, stoves or other heat-generating devices.
- 8. POWER SUPPLY**—The device should only be connected to a power supply of the type described in the operating instructions or as marked on the device.

- 9. POWER CORD PROTECTION**—Power cables should be routed so they are not likely to be stepped on or crushed by items placed on them or against them. Special attention should be paid to areas where the plug enters a socket or fused strip and where the cord exits the device.
- 10. CLEANING**—The device should be cleaned in accordance with manufacturer’s instructions. We recommend using a lint roller or household duster for the grille cloth.
- 11. PERIODS OF NON-USE**—The device should be unplugged when not being used for extended periods of time.
- 12. DANGEROUS ENTRY**—Care should be taken that no foreign objects or liquids fall or are spilled inside the device.
- 13. DAMAGE REQUIRING SERVICE**—The device should be serviced by licensed technicians when:
 - The plug or power supply cord has been damaged.
 - Objects have fallen on or liquid has spilled inside the device.
 - The device has been exposed to moisture.
 - The device does not appear to be operating properly or exhibits a marked change in performance.
 - The device has been dropped or the cabinet becomes damaged.
- 14. SERVICE**—The device should always be serviced by licensed technicians. Only replacement parts specified by the manufacturer should be used. The use of unauthorized substitutions may result in fire, shock, or other hazards.

POWER SUPPLY

- The fuse and power disconnect device are located on the back of the speaker.
- The disconnect device is the power cord, detachable at either the speaker or the wall.
- The power cord must be disconnected from the speaker before servicing.

This symbol on our electrical products or their packaging indicates that it is forbidden in Europe to discard the product in question as domestic waste. In order to ensure that you dispose of the products correctly, please dispose of the products according to local laws and regulations on the disposal of electrical and electronic equipment. In doing so you are contributing to the retention of natural resources and to the promotion of environmental protection by the treatment and disposal of electronic waste.



We're delighted that you're part of our Definitive Technology family.

Please take a few minutes to register your product* so we have a complete record of your purchase. Doing so helps us serve you the best we can now and in the future. It also lets us contact you for any service or warranty alerts (*if required*).

Register here: <http://www.definitivetechology.com/registration>

No internet? Call Customer Service

M-F 9:30 a.m. - 6 p.m. US ET

at (800) 228-7148 (US & Canada), 01 (410) 363-7148 (all other countries)

Note: the data we gather during online registration is never sold or distributed to third parties.

**Serial number can be found at the back of the manual*

Unpacking Your A90 Elevation Speaker Module

Please unpack your A90 elevation speaker module carefully. We recommend saving the carton and packing materials in case you move or need to ship your system. It is important to save this booklet, as it contains the serial number for your product. You can also find the serial number on the back of your A90. Each loudspeaker leaves our factory in perfect condition. Any visible or concealed damage most likely occurred in handling after it left our factory. If you discover any shipping damage, please report this to your Definitive Technology dealer or the company that delivered your loudspeaker.

Accessories Included:

1. (2) A90 Speakers

Connecting the A90 Elevation Speaker Module to Your BP9000 Loudspeakers

Using your hands, gently push down on the back of the magnetically-sealed aluminum top panel of your BP9000 speaker (*Figure 1*). Set the top panel aside temporarily and/or put away for safekeeping. We've designed your BP9000 speakers for the ultimate in design flexibility. So, feel free to keep the A90 module connected permanently it's connected placed, or remove it at the completion of each viewing experience.

Correctly align and place the A90 elevation speaker module within the top of your BP9000 speaker. Press down evenly to ensure a tight seal. The connector port on the inside perfectly mates with the connector plug on the underside of the A90 module (*Figure 2*).

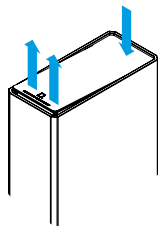

FIGURE 1 | Aluminum top panel removal

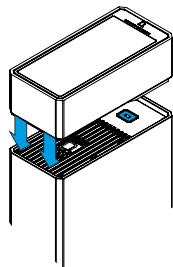
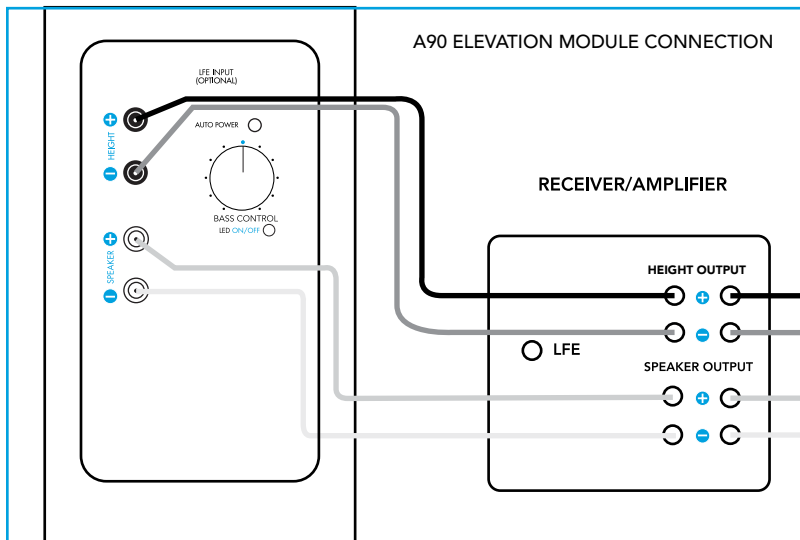

FIGURE 2 | A90 Placement

Connecting Your A90 Elevation Module

Now, run speaker wire from any compatible Atmos or DTS:X receiver binding posts (often titled HEIGHT) to the top set of binding posts (titled: HEIGHT) on the bottom, rear side of your BP9000 speakers. Be sure to match + to +, and – to –.



Note: The A90 elevation speaker module for your BP9000 speakers requires an Dolby Atmos/DTS:X-enabled receiver and is maximized by Dolby Atmos/DTS:X-encoded source material. Visit www.dolby.com or www.dts.com for more information on available titles.

Ceiling Height for the Optimal Dolby Atmos® or DTS:X™ Experience

It's important to know that the A90 elevation module is a height speaker that bounces sound off a ceiling and back toward your viewing area. With that in mind, your ceiling plays an important role in the experience.

To achieve the best Dolby Atmos or DTS:X experience possible:

- Your ceiling should be flat
- Your ceiling material should be acoustically reflective (examples include drywall, plaster, hardwood or other rigid, non-sound absorbing material)
- Ideal ceiling height is between 7.5 and 12 feet
- Maximum recommended height is 14 feet

Receiver Setup Recommendations

To experience either revolutionary sound technology, you must have a way to play or stream Dolby Atmos or DTS:X content.

Note: please reference your receiver/processor owner's manual for complete directions, or give us a call.

Options to Play or Stream Content

1. You can play Dolby Atmos or DTS:X content from a Blu-ray Disc through an existing Blu-ray Disc player. Be sure you have a player that's fully compliant with Blu-ray specifications.

Or

2. You can stream content from a compatible game console, Blu-ray, or streaming media player. In both cases, be sure to set your player to bitstream output.

Note: Dolby Atmos and DTS:X are compatible with the current HDMI® specification (v1.4 and later). For more information, visit www.dolby.com or www.dts.com.

Maximizing Your New Home Theater

While certified Dolby Atmos or DTS:X content will be maximized on your new system, nearly any content can be improved with the addition of your A90 height modules. For example, nearly all Dolby Atmos receivers feature a Dolby surround upmixer function that automatically adapts any traditional channel-based signal to the new, full capabilities of your system, including your A90 height modules. This ensures that you hear realistic and immersive three-dimensional sound no matter what you're playing. Please reference your receiver/processor owner's manual for complete information.

A90

SPECIFICATIONS (EACH)

DIMENSIONS	3.75" H x 6" W x 13" D (9.5 cm x 15.2 cm x 33 cm)
PRODUCT WEIGHT	6 lbs.
DRIVER COMPLEMENT	(1) 4.5" driver, (1) 1" aluminum dome tweeter
SUBWOOFER SYSTEMS DRIVER COMPLEMENT	none
FREQUENCY RESPONSE	86Hz-40kHz
SENSITIVITY	89.5dB
IMPEDANCE	8 ohms
RECOMMENDED INPUT POWER	25-100W
NOMINAL POWER (1% THD, 5SEC.)	none

Technical Assistance

It is our pleasure to offer assistance if you have any questions regarding your BP9000 or its setup. Please contact your nearest Definitive Technology dealer or call us directly at (800) 228-7148 (US & Canada), 01 (410) 363-7148 (all other countries) or e-mail info@definitivetech.com. Technical support is offered in English only.

Service

Service and warranty work on your Definitive loudspeakers will normally be performed by your local Definitive Technology dealer. If, however, you wish to return the speaker to us, please contact us first, describing the problem and requesting authorization as well as the location of the nearest factory service center. Please note that the address given in this booklet is the address of our offices only. Under no circumstances should loudspeakers be shipped to our offices or returned without contacting us first and obtaining return authorization.

Definitive Technology Offices

1 Viper Way, Vista, CA 92081

Phone: (800) 228-7148 (US & Canada), 01 (410) 363-7148 (all other countries)

Troubleshooting

If you experience any difficulties with your BP9000 speakers, try the suggestions below. If you still have problems, contact your Definitive Technology Authorized Dealer for assistance.

1. Audible distortion when the speakers are playing at loud levels is caused by turning up your receiver or amplifier louder than the receiver or the speakers are capable of playing. Most receivers and amplifiers put out their full-rated power well before the volume control is turned all the way up, so the position of the volume control is a poor indicator of its power limit. If your speakers distort when you play them loud, turn the volume down!
2. If you experience a lack of bass, it is likely that one speaker is out of phase (polarity) with the other and needs to be rewired with closer attention to connecting positive to positive and negative to negative on both channels. Most speaker wire has some indicator (such as color-coding, ribbing or writing) on one of the two conductors to help you maintain consistency. It is essential to connect both speakers to the amplifier in the same way (in phase). You may also experience lack of bass if the bass volume knob is turned down or not on.
3. Make sure all your system interconnects and power cords are solidly in place.
4. Should you hear hum or noise coming from your speakers, try plugging the speakers' power cords into a different AC circuit.
5. The system has sophisticated internal protection circuitry. If for some reason the protection circuitry trips, turn off your system and wait five minutes before trying the system again. If the speakers' built-in amplifier should overheat, the system will turn off until the amplifier cools down and resets.
6. Check to be sure that your power cord has not been damaged.
7. Check that no foreign objects or liquid has entered the speaker cabinet.
8. If you cannot get the subwoofer driver to turn on or if no sound comes out and you are sure the system is set up properly, please bring the loudspeaker to your Definitive Technology Authorized Dealer for assistance; call first

Limited Warranty:

5-Years for Drivers and Cabinets, 3-Years for Electronic Components

DEI Sales Co., dba Definitive Technology (herein "Definitive") warrants to the original retail purchaser only that this Definitive loudspeaker product (the "Product") will be free from defects in material and workmanship for a period of five (5) years covering the drivers and cabinets, and three (3) years for the electronic components from the date of the original purchase from a Definitive Authorized Dealer. If the Product is defective in material or workmanship, Definitive or its Authorized Dealer will, at its option, repair or replace the warranted product at no additional charge, except as set forth below. All replaced parts and Product(s) become the property of Definitive. Product that is repaired or replaced under this warranty will be returned to you, within a reasonable time, freight collect. This warranty is non-transferrable and is automatically void if the original purchaser sells or otherwise transfers the Product to any other party.

This Warranty does not include service or parts to repair damage caused by accident, misuse, abuse, negligence, inadequate packing or shipping procedures, commercial use, voltage in excess of the rated maximum of the unit, cosmetic appearance of cabinetry not directly attributable to defects in material or workmanship. This warranty does not cover the elimination of externally generated static or noise, or the correction of antenna problems or weak reception. This warranty does not cover labor costs or damage to the Product caused by installation or removal of the Product. Definitive Technology makes no warranty with respect to its products purchased from dealers or outlets other than Definitive Technology Authorized Dealer.

THE WARRANTY IS AUTOMATICALLY VOID IF:

- 1) The product has been damaged, altered in any way, mishandled during transportation, or tampered with.
- 2) The product is damaged due to accident, fire, flood, unreasonable use, misuse, abuse, customer applied cleaners, failure to observe manufacturers warnings, neglect or related events.
- 3) Repair or modification of the Product has not been made or authorized by Definitive Technology.
- 4) The product has been improperly installed or used.

Product must be returned (insured and prepaid), together with the original dated proof of purchase to the Authorized Dealer from whom the Product was purchased, or to the nearest Definitive factory service center.

Product must be shipped in the original shipping container or its equivalent. Definitive is not responsible or liable for loss or damage to Product in transit.

THIS LIMITED WARRANTY IS THE ONLY EXPRESS WARRANTY THAT APPLIES TO YOUR PRODUCT. DEFINITIVE NEITHER ASSUMES NOR AUTHORIZES ANY PERSON OR ENTITY TO ASSUME FOR IT ANY OTHER OBLIGATION OR LIABILITY IN CONNECTION WITH YOUR PRODUCT OR THIS WARRANTY. ALL OTHER WARRANTIES, INCLUDING BUT NOT LIMITED TO EXPRESS, IMPLIED, WARRANTY OF MERCHANTABILITY OR FITNESS FOR A PARTICULAR PURPOSE, ARE EXPRESSLY EXCLUDED AND DISCLAIMED TO THE MAXIMUM EXTENT ALLOWED BY LAW. ALL IMPLIED WARRANTIES ON PRODUCT ARE LIMITED TO THE DURATION OF THIS EXPRESSED WARRANTY. DEFINITIVE HAS NO LIABILITY FOR ACTS OF THIRD PARTIES. DEFINITIVE'S LIABILITY, WHETHER BASED ON CONTRACT, TORT, STRICT LIABILITY, OR ANY OTHER THEORY, SHALL NOT EXCEED THE PURCHASE PRICE OF THE PRODUCT FOR WHICH A CLAIM HAS BEEN MADE. UNDER NO CIRCUMSTANCE WILL DEFINITIVE BEAR ANY LIABILITY FOR INCIDENTAL, CONSEQUENTIAL OR SPECIAL DAMAGES. THE CONSUMER AGREES AND CONSENTS THAT ALL DISPUTES BETWEEN THE CONSUMER AND DEFINITIVE SHALL BE RESOLVED IN ACCORDANCE WITH CALIFORNIA LAWS IN SAN DIEGO COUNTY, CALIFORNIA. DEFINITIVE RESERVES THE RIGHT TO MODIFY THIS WARRANTY STATEMENT AT ANY TIME.

Some states do not allow the exclusion or limitation of consequential or incidental damages, or implied warranties, so the above limitations may not apply to you. This warranty gives you specific legal rights, and you may also have other rights which vary from state to state.

©2016 DEI Sales Co. All rights reserved.



Definitive Technology
1 Viper Way
Vista, CA 92082
(800) 228-7148

www.definitivetechology.com

HBP3620C