

CHANNEL	VALUE	FUNCTION
10	0 ↔ 255	RED 1
11	0 ↔ 255	GREEN1
12	0 ↔ 255	BLUE1
13	0 ↔ 255	WHITE1
14	0 ↔ 255	RED2
15	0 ↔ 255	GREEN2
16	0 ↔ 255	BLUE2
17	0 ↔ 255	WHITE 2
18	0 ↔ 255	RED3
19	0 ↔ 255	GREEN3
20	0 ↔ 255	BLUE3
21	0 ↔ 255	WHITE3
22	0 ↔ 255	RED4
23	0 ↔ 255	GREEN4
24	0 ↔ 255	BLUE4
25	0 ↔ 255	WHITE4
26	0 ↔ 255	RED 5
27	0 ↔ 255	GREEN5
28	0 ↔ 255	BLUE5
29	0 ↔ 255	WHITE 5
30	0 ↔ 255	RED 6
31	0 ↔ 255	GREEN6
32	0 ↔ 255	BLUE6
33	0 ↔ 255	WHITE 6
34	0 ↔ 255	RED 7
35	0 ↔ 255	GREEN7
36	0 ↔ 255	BLUE7
37	0 ↔ 255	WHITE7

PLUTO 2000XE

USER MANUAL

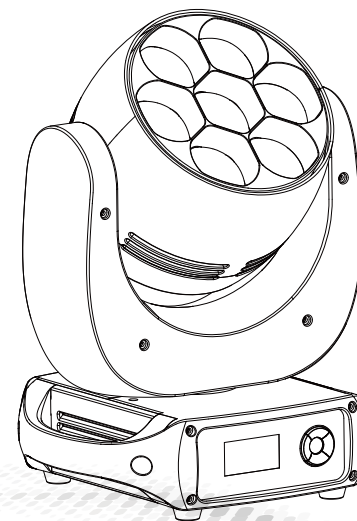

1 PRODUCT SPECIFICATIONS

1.1 PRODUCT SPECIFICATIONS

Electrical

- ◆ Voltage: 100V-240V~, 50/60Hz
- ◆ Max Power: 300W
- ◆ Size: 375x302x251mm
- ◆ Weight: 9.3kg

1.2 PRODUCT FEATURES

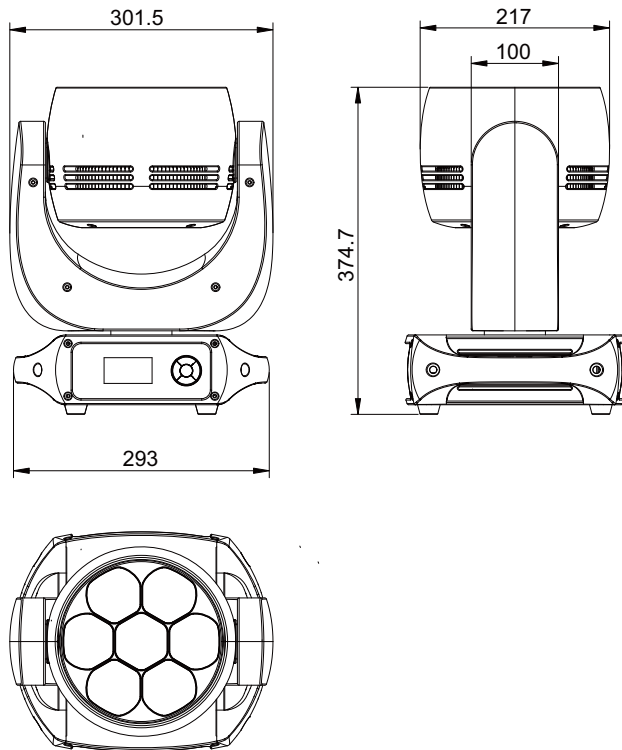

PIXEL

CHANNEL	VALUE	FUNCTION
1	0 ↔ 255	PAN
2	0 ↔ 255	PAN FINE
3	0 ↔ 255	TILT
4	0 ↔ 255	TILT FINE
5	0 ↔ 255	PT SPEED
6	0 ↔ 255	DIMMER
		STROBE
	0 ↔ 9	NO FUNCTION
7	10 ↔ 99	STROBE FROM (SLOD TO FAST , 0-25Hz)
	100 ↔ 109	NO FUNCTION
	110 ↔ 179	LIGHTNING STROBE
	180 ↔ 189	NO FUNCTION
	190 ↔ 255	RANDOM SROBE
8	0 ↔ 255	ZOOM
		CONTROL
	0 ↔ 9	NO FUNCTION
	10 ↔ 19	PAN/TILT BLACKACTIVATED
	20 ↔ 29	PAN/TILT BLACK DEACTIVATED
	30 ↔ 39	FAN SLOW
	40 ↔ 49	FAN NORMAL
	50 ↔ 59	FAN FAST
	60 ↔ 69	FAN AUTO
9	70 ↔ 79	AUTO1
	80 ↔ 89	AUTO2
	90 ↔ 99	CUSTOM
	100 ↔ 109	TEST
	110 ↔ 119	RESET
	120 ↔ 129	NO FUNCTION
	130 ↔ 139	DIM0
	140 ↔ 149	DIM1
	150 ↔ 159	DIM2
160 ↔ 169	DIM3	
170 ↔ 179	DIM4	
180 ↔ 255	NO FUNCTION	

CHANNEL	VALUE	FUNCTION
12		STROBE
	0 ↔ 9	NO FUNCTION
	10 ↔ 99	STROBE FROM (SLOD TO FAST , 0-25Hz)
	100 ↔ 109	NO FUNCTION
	110 ↔ 179	LIGHTNING STROBE
	180 ↔ 189	NO FUNCTION
13	190 ↔ 255	RANDOM SROBE
	0 ↔ 255	ZOOM
14		CONTROL
	0 ↔ 9	NO FUNCTION
	10 ↔ 19	PAN/TILT BLACK ACTIVATED
	20 ↔ 29	PAN/TILT BLACK DEACTIVATED
	30 ↔ 39	FAN SLOW
	40 ↔ 49	FAN NORMAL
	50 ↔ 59	FAN FAST
	60 ↔ 69	FAN AUTO
	70 ↔ 79	AUTO1
	80 ↔ 89	AUTO2
	90 ↔ 99	CUSTOM
	100 ↔ 109	TEST
	110 ↔ 119	RESET
	120 ↔ 129	NO FUNCTION
	130 ↔ 139	DIM0
	140 ↔ 149	DIM1
	150 ↔ 159	DIM2
	160 ↔ 169	DIM3
170 ↔ 179	DIM4	
180 ↔ 255	NO FUNCTION	

1.3 SAFETY WARNING

IMPORTANT:

- This product must be installed by a qualified professional.
- All maintenance must be carried out by a qualified electrician.
- A minimum distance of 0.5m must be maintained between the equipment and a combustible surface.
- The product must always be operated in a well ventilated area.
- DO NOT stare directly into the LED light source.
- Always disconnect the power before carrying out any maintenance.
- The earth must always be connected to the ground.
- Ensure that all parts of the equipment are kept clean and free of dust.



Caution, risk of electric shock
The light source contained in this luminaire shall only be replaced by the manufacturer or his service agent or a similar qualified person.

2 INSTALLATION

2.1 MOUNTING:

- The fixture can be mounted in any position.
- Always ensure that mounting surface can withstand 10 times the weight of the fixture.
- Always use a safety cable when mounting the fixture in any elevated position.

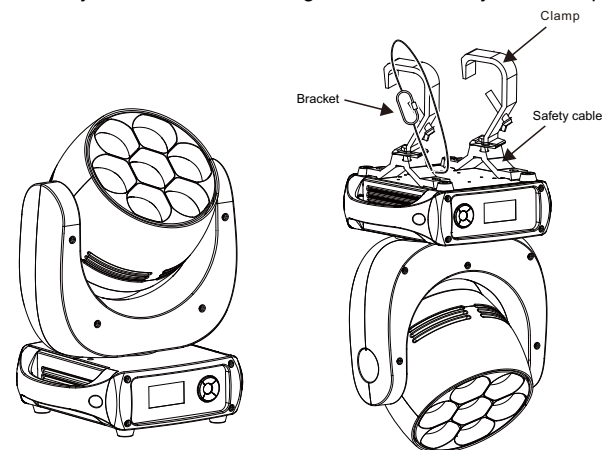

IMPORTANT SAFETY NOTE!!

Always use a safety cable when installing this unit!!
Be sure that the safety cable is connected to a solid load-bearing structure.

2.2 FUSE REPLACEMENT

- Remove the safety cap by a screwdriver.
- Fetch the old fuse from safety cap.
- Install a new fuse.
- Install the safety cap.

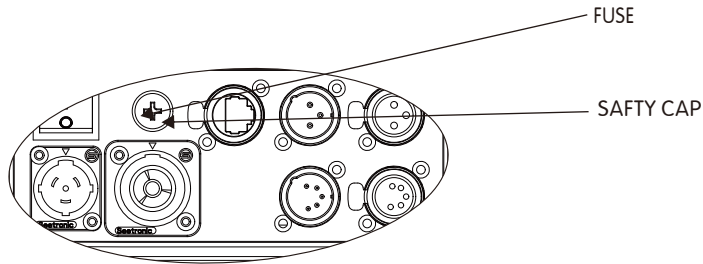

2.3 POWER CONNECTIONS

- 220~240V: 6 units may be connected in series
- 110~120V: 3 units may be connected in series

Note:

If the signal cable is over 60m between the DMX512 controller and fixture or between two fixtures, then a DMX signal amplifier is needed as well.

3 DISPLAY PANEL OPERATION

3.1 DISPLAY OPERATION

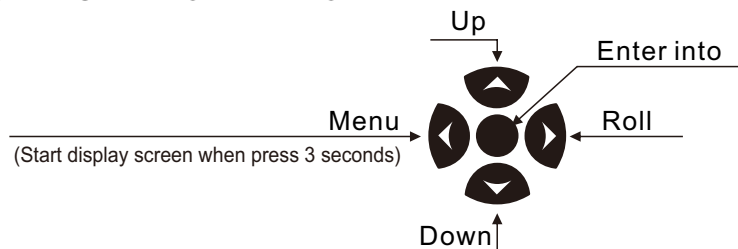

CHANNEL	VALUE	FUNCTION	SINGLE POINT CONTROL FUNCTION
68 ↔ 71	static 16		1,2,3
72 ↔ 45	static 17		1,4,5
76 ↔ 79	static 18		1,6,7
80 ↔ 83	static 19		1,2,5
84 ↔ 87	static 20		1,3,6
88 ↔ 91	static 21		1,4,7
92 ↔ 95	static 22		3,5,7
96 ↔ 99	static 23		5,6,7
100 ↔ 103	static 24		1,3,5,7
104 ↔ 107	static 25		1,5,6,7
108 ↔ 111	static 26		1,2,4,5,7
112 ↔ 115	static 27		1,2,3,5,6
116 ↔ 119	static 28		1,3,4,6,7
120 ↔ 123	static 29		2,3,4,5,6,7
124 ↔ 127	black		DARK
128 ↔ 135	static ALL		BRIGHT
136 ↔ 145	RING1	slow->fast	(2)-(3)-(4)-(5)-(6)-(7)
146 ↔ 155	RING2A	slow->fast	(2,3)-(4,5)-(6,7)
156 ↔ 165	RING2B	slow->fast	(2,5)-(3,6)-(4,7)
166 ↔ 175	RING2C	slow->fast	(1,2)-(1,3)-(1,4)-(1,5)-(1,6)-(1,7)
176 ↔ 185	RING3A	slow->fast	(2,3,4)-(5,6,7)
186 ↔ 195	RING3B	slow->fast	(1,2,3)-(1,4,5)-(1,6,7)
196 ↔ 205	RING3C	slow->fast	(1,2,5)-(1,3,6)-(1,4,7)
206 ↔ 215	RING3D	slow->fast	(2,5,7)-(1,4,6)
216 ↔ 225	RING3E	slow->fast	(2,3,4)-(3,4,5)-(4,5,6)-(5,6,7)-(6,7,2)-(7,2,3)
226 ↔ 235	RING4	slow->fast	(1,2,3,5,6)-(1,3,4,6,7)-(1,4,5,7)
236 ↔ 245	RING5	slow->fast	(1,2,3,5,6)-(1,3,4,6,7)-(1,4,5,7,2)
246 ↔ 255	GINR6	slow->fast	(1)-(2,3,4,5,6,7)

11

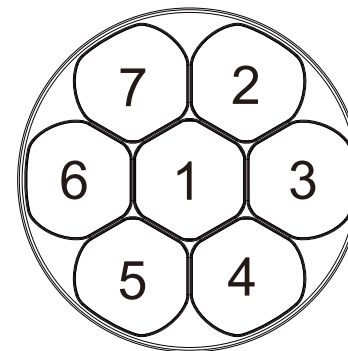

To identify up, middle and down by head which after the fixture electrify & reset

CMY

CHANNEL	VALUE	FUNCTION	SINGLE POINT CONTROL FUNCTION
1	0 ↔ 255	PAN	
2	0 ↔ 255	PAN FINE	
3	0 ↔ 255	TITL	
4	0 ↔ 255	TITL FINE	
5	0 ↔ 255	PT SPEED	
6	0 ↔ 255	CYAN	
7	0 ↔ 255	MAGENT	
8	0 ↔ 255	YELLOW	
9	0 ↔ 255	DIMMER	
		MARCOS	
	0 ↔ 9	NO FUNCTION	
	10 ↔ 29	RED 100% / GREEN UP / BLUE 0%	
	30 ↔ 49	RED DOWN / GREEN 100% / BLUE 0%	
	50 ↔ 69	RED 0% / GREEN 100% / BLUE UP	
	70 ↔ 89	RED 0% / GREEN DOWN / BLUE 100%	
	90 ↔ 109	RED UP / GREEN 0% / BLUE 100%	
	110 ↔ 129	RED 100% / GREEN 0% / BLUE DOWN	
10	130 ↔ 149	RED 100% / GREEN UP / BLUE UP	
	150 ↔ 169	RED DOWN / GREEN DOWN / BLUE 100%	
	170 ↔ 189	ALL LED AT FULL OUTPUT	
	190 ↔ 199	2700K	
	200 ↔ 209	3200K	
	210 ↔ 219	4200K	
	220 ↔ 229	5600K	
	230 ↔ 239	6500K	
	240 ↔ 255	8000K	
		A SINGLE POINT	
	0 ↔ 7	NO FUNCTION	
	8 ↔ 11	static 1	1
	12 ↔ 15	static 2	2
	16 ↔ 19	static 3	3
	20 ↔ 23	static 4	4
	24 ↔ 27	static 5	5
	28 ↔ 31	static 6	6
11	32 ↔ 35	static 7	7
	36 ↔ 39	static 8	2,3
	40 ↔ 43	static 9	4,5
	44 ↔ 47	static 10	6,7
	48 ↔ 51	static 11	2,5
	52 ↔ 55	static 12	3,6
	56 ↔ 59	static 13	4,7
	60 ↔ 63	static 14	2,3,4
	64 ↔ 67	static 15	5,6,7

3.2 MENU MAP

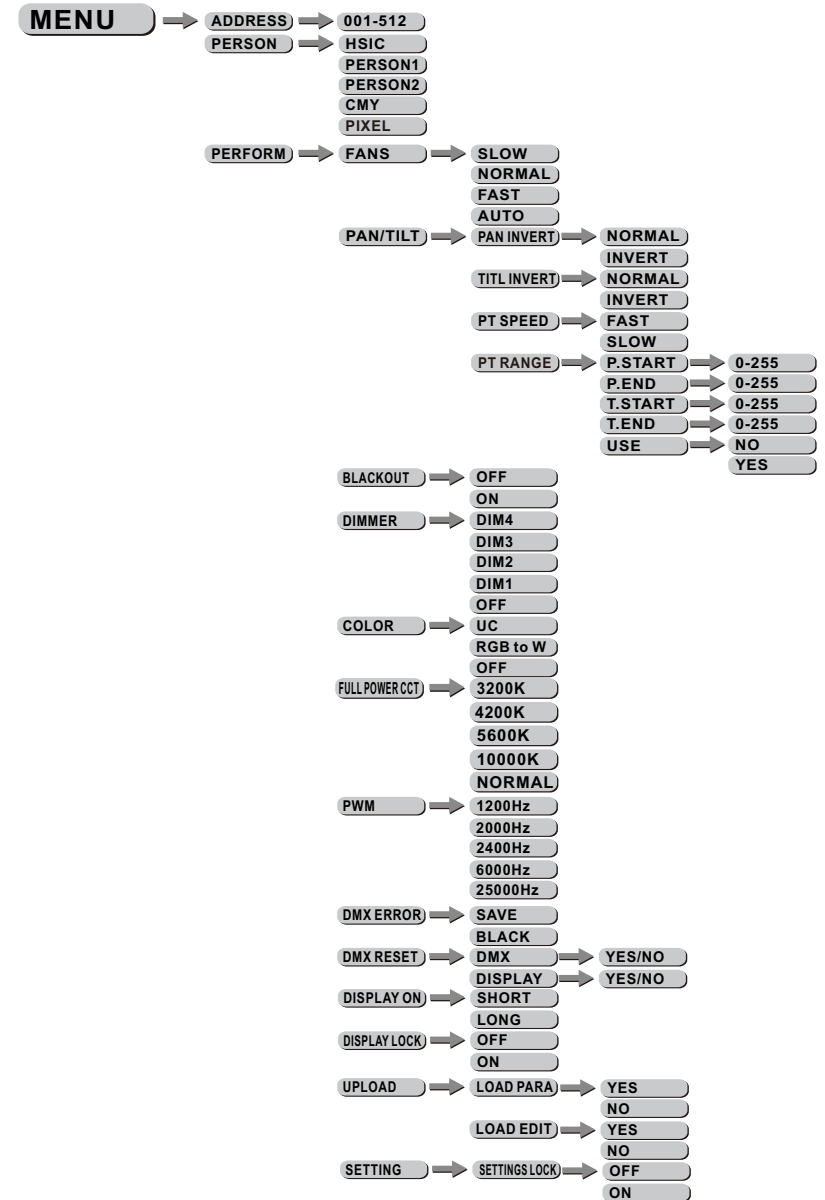

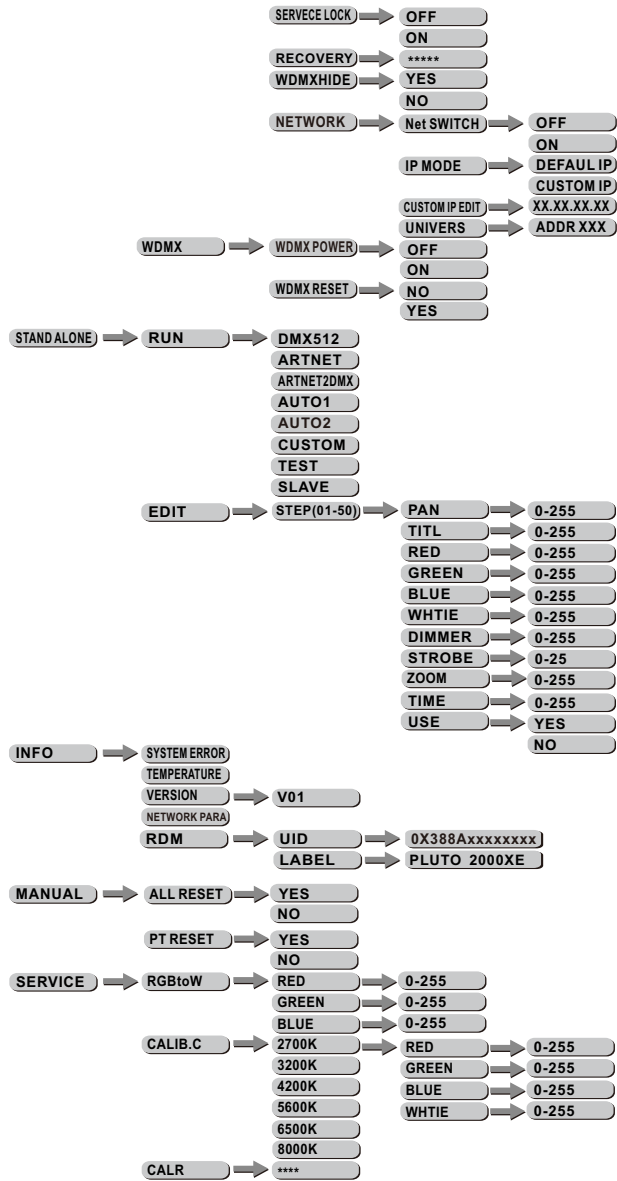

CHANNEL	VALUE	FUNCTION
18		STROBE
	0 ↔ 9	NO FUNCTION
	10 ↔ 99	STROBE FROM (SLOD TO FAST , 0-25Hz)
	100 ↔ 109	NO FUNCTION
	110 ↔ 179	LIGHTNING STROBE
	180 ↔ 189	NO FUNCTION
	190 ↔ 255	RANDOM SROBE
19	0 ↔ 255	ZOOM
		CONTROL
20	0 ↔ 9	NO FUNCTION
	10 ↔ 19	PAN/TILT BLACK ACTIVATED
	20 ↔ 29	PAN/TILT BLACK DEACTIVATED
	30 ↔ 39	FAN SLOW
	40 ↔ 49	FAN NORMAL
	50 ↔ 59	FAN FAST
	60 ↔ 69	FAN AUTO
	70 ↔ 79	AUTO1
	80 ↔ 89	AUTO2
	90 ↔ 99	CUSTOM
	100 ↔ 109	TEST
	110 ↔ 119	RESET
	120 ↔ 129	NO FUNCTION
130 ↔ 139	DIM0	
140 ↔ 149	DIM1	
150 ↔ 159	DIM2	
160 ↔ 169	DIM3	
170 ↔ 179	DIM4	
180 ↔ 255	NO FUNCTION	

CHANNEL	VALUE	FUNCTION	SINGLE POINT CONTROL FUNCTION
	36 ↔ 39	static 8	2,3
	40 ↔ 43	static 9	4,5
	44 ↔ 47	static 10	6,7
	48 ↔ 51	static 11	2,5
	52 ↔ 55	static 12	3,6
	56 ↔ 59	static 13	4,7
	60 ↔ 63	static 14	2,3,4
	64 ↔ 67	static 15	5,6,7
	68 ↔ 71	static 16	1,2,3
	72 ↔ 75	static 17	1,4,5
	76 ↔ 79	static 18	1,6,7
	80 ↔ 83	static 19	1,2,5
	84 ↔ 87	static 20	1,3,6
	88 ↔ 91	static 21	1,4,7
	92 ↔ 95	static 22	3,5,7
	96 ↔ 99	static 23	5,6,7
	100 ↔ 103	static 24	1,3,5,7
	104 ↔ 107	static 25	1,5,6,7
	108 ↔ 111	static 26	1,2,4,5,7
	112 ↔ 115	static 27	1,2,3,5,6
	116 ↔ 119	static 28	1,3,4,6,7
	120 ↔ 123	static 29	2,3,4,5,6,7
	124 ↔ 127	black	DARK
	128 ↔ 135	static ALL	BRIGHT
	136 ↔ 145	RING1 slow-->fast	(2)-(3)-(4)-(5)-(6)-(7)
	146 ↔ 155	RING2A slow-->fast	(2,3)-(4,5)-(6,7)
	156 ↔ 165	RING2B slow-->fast	(2,5)-(3,6)-(4,7)
	166 ↔ 175	RING2C slow-->fast	(1,2)-(1,3)-(1,4)-(1,5)-(1,6)-(1,7)
	176 ↔ 185	RING3A slow-->fast	(2,3,4)-(5,6,7)
	186 ↔ 195	RING3B slow-->fast	(1,2,3)-(1,4,5)-(1,6,7)
	196 ↔ 205	RING3C slow-->fast	(1,2,5)-(1,3,6)-(1,4,7)
	206 ↔ 215	RING3D slow-->fast	(2,5,7)-(1,4,6)
	216 ↔ 225	RING3E slow-->fast	(2,3,4)-(3,4,5)-(4,5,6)-(5,6,7)-(6,7,2)-(7,2,3)
	226 ↔ 235	RING4 slow-->fast	(1,2,3,5,6)-(1,3,4,6,7)-(1,4,5,7)
	236 ↔ 245	RING5 slow-->fast	(1,2,3,5,6)-(1,3,4,6,7)-(1,4,5,7,2)
	246 ↔ 255	GINR6 slow-->fast	(1)-(2,3,4,5,6,7)

17

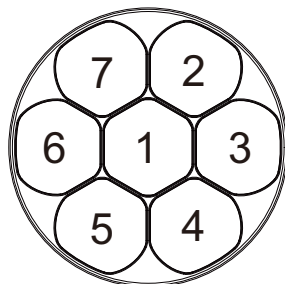

To identify up, middle and down by head which after the fixture electrify & reset

3.3 DMX512 SETTINGS

MENU → **ADDRESS** → 001-512

- Enter the **[DMX]** mode to set the DMX ADDRESS.

3.4 PERSONALITY

MENU → **PERSON** → **HSIC**
PERSON1
PERSON2
CMY
PIXEL

- Enter the **[PERSON]** mode to select DMX mode: **[HSIC]**, **[PERSON1]**, **[PERSON2]**, **[CMY]**, **[PIXEL]**,

3.5 PERFORM

MENU → **PERFORM** → **FANS** → **SLOW**
NORMAL
FAST
AUTO

PAN/TILT → **PANINVERT** → **NORMAL**
INVERT

TITLINVERT → **NORMAL**
INVERT

PT SPEED → **FAST**
SLOW

PT RANGE → **P.START** → 0-255
P.END → 0-255
T.START → 0-255
T.END → 0-255
USE → **NO**
YES

BLACKOUT → **OFF**
ON

DIMMER → **DIM4**
DIM3
DIM2
DIM1
OFF

COLOR → **UC**
RGB to W
OFF

FULL POWER CCT → **3200K**
4200K
5600K
10000K
NORMAL

PWM → **1200Hz**
2000Hz
2400Hz
6000Hz
25000Hz

DMX ERROR → **SAVE**
BLACK

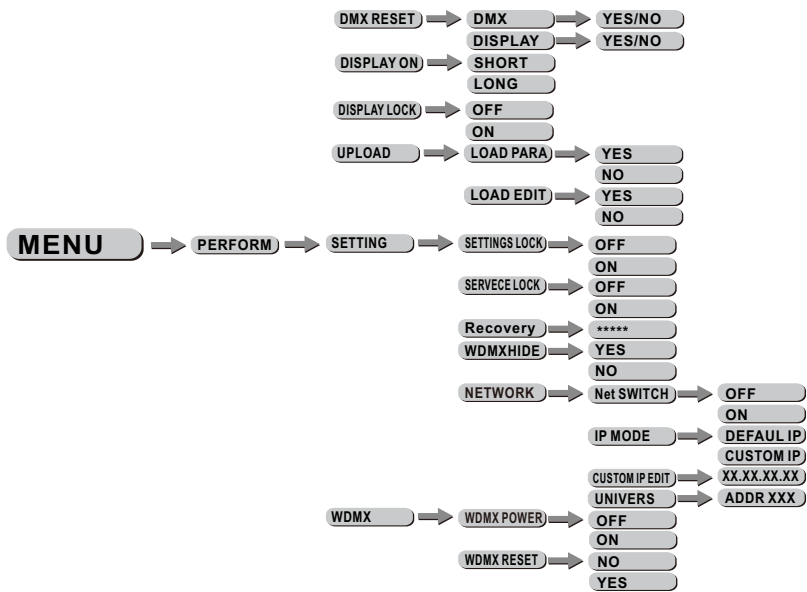

- **【FANS】** menu, select **【Slow/Norm/Fast/Auto】** as required fan speed.
- **【PAN INVERT】** menu, select **【NORM/INVERT】** for normal/inverted control of the PAN function
- **【TILT INVERT】** menu, select **【NORM/INVERT】** for normal/inverted control of the TILT function
- **【PT SPEED】** menu, select **【Slow/Fast】** as required PAN/TILT movement speed.
- **【BLACKD】** menu, select **【OFF】** for immediate activation of PAN/TILT blackout when selected using the control channel or **【ON】** for 3 second delay before activation.
- **【DIMMER】** menu for selection of **【DIM1/DIM2/DIM3/DIM4/OFF】** special dimming curves
- **【COLOR】** is for activate/unactivate the color calibration functions. When **[RGBtoW]** is selected, on RGB = 255,255,255, the color is displayed as calibrated in Service -- RGBtoW. When **[COLOR]** is set **[OFF]**, on RGB = 255,255,255, the RGB values are not adjusted and the output is most powerful. When **[UC]** is selected, the RGB output are adjusted to a standard preset universal color which balances fixtures from different generations.
- **【FULL POWER CCT】** is the color temperature choose bottom, press UP/DOWN to choose, under full power, <3200K>, <4200K>, <5600K>, <10000K> can be chosen, when choose <COLOR>, <3200K>, <4200K>, <5600K>, <10000K> are not work, but choose <NORMAL>.
- **【PWM】** is PWM refresh rate bottom, press UP/DOWN to choose <1200Hz>, <2000Hz>, <2400Hz>, <6000Hz>, <25000Hz>
Note: with refresh rate increased, gray rate of dimmer will be reduced

PERSON2

CHANNEL	VALUE	FUNCTION	SINGLE POINT CONTROL FUNCTION
1	0 ↔ 255	PAN	
2	0 ↔ 255	PAN FINE	
3	0 ↔ 255	TITL	
4	0 ↔ 255	TITL FINE	
5	0 ↔ 255	PT SPEED	
6	0 ↔ 255	RED	
7	0 ↔ 255	RED FINE	
8	0 ↔ 255	GREEN	
9	0 ↔ 255	GREEN FINE	
10	0 ↔ 255	BLUE	
11	0 ↔ 255	BLUE FINE	
12	0 ↔ 255	WHTIE	
13	0 ↔ 255	WHTIE FINE	
14	0 ↔ 255	DIMMER	
15	0 ↔ 255	DIMMER FINE	
		MARCOS	
	0 ↔ 9	NO FUNCTION	
	10 ↔ 29	RED 100% / GREEN UP / BLUE 0%	
	30 ↔ 49	RED DOWN / GREEN 100% / BLUE 0%	
	50 ↔ 69	RED 0% / GREEN 100% / BLUE UP	
	70 ↔ 89	RED 0% / GREEN DOWN / BLUE 100%	
	90 ↔ 109	RED UP / GREEN 0% / BLUE 100%	
	110 ↔ 129	RED 100% / GREEN 0% / BLUE DOWN	
16	130 ↔ 149	RED 100% / GREEN UP / BLUE UP	
	150 ↔ 169	RED DOWN / GREEN DOWN / BLUE 100%	
	170 ↔ 189	ALL LED AT FULL OUTPUT	
	190 ↔ 199	2700K	
	200 ↔ 209	3200K	
	210 ↔ 219	4200K	
	220 ↔ 229	5600K	
	230 ↔ 239	6500K	
	240 ↔ 255	8000K	
		A SINGLE POINT	
	0 ↔ 7	NO FUNCTION	
	8 ↔ 11	static 1	1
	12 ↔ 15	static 2	2
17	16 ↔ 19	static 3	3
	20 ↔ 23	static 4	4
	24 ↔ 27	static 5	5
	28 ↔ 31	static 6	6
	32 ↔ 35	static 7	7

CHANNEL	VALUE	FUNCTION
10		STROBE
	0 ↔ 9	NO FUNCTION
	10 ↔ 99	STROBE FROM (SLOD TO FAST , 0-25Hz)
	100 ↔ 109	NO FUNCTION
	110 ↔ 179	LIGHTNING STROBE
	180 ↔ 189	NO FUNCTION
11	190 ↔ 255	RANDOM SROBE
	0 ↔ 255	ZOOM
12		CONTROL
	0 ↔ 9	NO FUNCTION
	10 ↔ 19	PAN/TILT BLACK ACTIVATED
	20 ↔ 29	PAN/TILT BLACK DEACTIVATED
	30 ↔ 39	FAN SLOW
	40 ↔ 49	FAN NORMAL
	50 ↔ 59	FAN FAST
	60 ↔ 69	FAN AUTO
	70 ↔ 79	AUTO1
	80 ↔ 89	AUTO2
	90 ↔ 99	CUSTOM
	100 ↔ 109	TEST
	110 ↔ 119	RESET
	120 ↔ 129	NO FUNCTION
	130 ↔ 139	DIM0
	140 ↔ 149	DIM1
	150 ↔ 159	DIM2
	160 ↔ 169	DIM3
170 ↔ 179	DIM4	
180 ↔ 255	NO FUNCTION	

- **[DMXERROR]** menu, select **[SAVE]** to maintain last command in case of DMX error or **[BLACK]** for blackout
- **[DMXRESET]** menu, select **[DMX]** to allow remote reset using DMX controller or **[DISPLAY]** for reset only available at on-fixture display
- **[DISPLAY ON]** menu, select **[LONG/SHORT/DISPLAY LOCK]** for length of time for display backlight
- **[UPLOAD]** upload data setting, choose **[LOAD PARA]** to upload data, choose **[NO]** means do not upload data choose **[YES]** means upload data, choose **[LOAD EDIT]** to program, choose **[NO]** means do not upload, choose **[YES]** means upload
- **[SETTING]** is a protect bottom, **[SETTINGS LOCK]** is the menu lock bottom, choose **[OFF]** means the menu lock bottom is off, choose **[ON]** means the menu lock bottom is on **[RECOVERY]** is the recover to default value.Press **[ENTER]** to password setting, press correct password **[UP+DOWN+UP+DOWN]** ,and press **[ENTER]** ,if password is correct, display will show **[OK]** ,
- **[NET SWITCH]** is net switch, OFF adhere to 2.XX.XX.XX , ON adhere to 2.XX.XX.XX, **[IP MODE]** is IP mode setting, "DEFAULT IP" is default IP, CUSTOM IP is user IP, **[CUSTOM IP SET]** is customer IP setting, **[UNIVERS]** is data bulk setting, output series 0-255
- **[WDMX]** setting , choose **[WDMX POWER]** to turn on/off the DMX , choose **[OFF]** to turn off it . **[ON]** to turn on it . Choose **[WDMX RESET]** to reset the DMX , choose **[NO]** , then DMX will not reset , **[YES]** , then DMX will reset

3.6 RUN

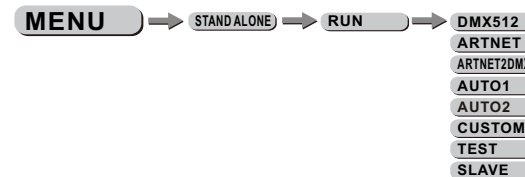

- Enter the **[STAND ALONE]** menu to select from **[DMX512/ARTNET/ARTNET2DMX/AUTO 1/AUTO 2/CUSTOM/TEST/SLAVE]** run modes

3.7 EDIT

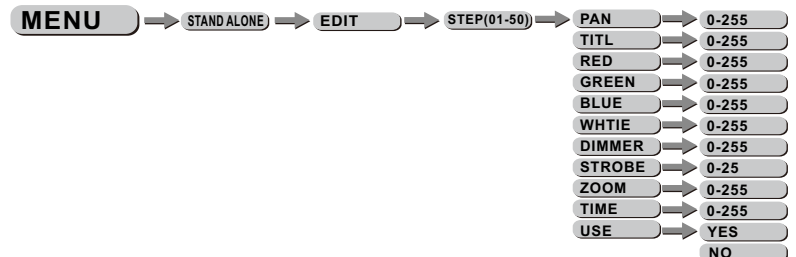

- Enter the **【EDIT】** mode to edit the custom programs by adjusting the value of **【PAN】**, **【TILT】**, **【RED】**, **【GREEN】**, **【BLUE】**, **【WHITE】**, **【DIMMER】**, **【STROBE】**, **【ZOOM】**, **【TIME】**
- Enter **【USE】** and select **【YES】** to run the steps user need.

Note: if user want to circulate the created steps, please set the last step ‘s **【Time】** as 0

For example, there are 3 steps, the setting should be like belowed:

- Step 1 **【Time】** = 4 **【Use】** = Yes
- Step 2 **【Time】** = 5 **【Use】** = Yes
- Step 3 **【Time】** = 0 **【Use】** = Yes

3.8 INFO

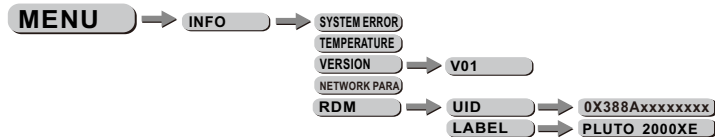

- push **【OK】** button into the information search mode in menu **【INFO】**, push **【up/down】** to choose item.

Choose **【SYSTEM ERROR】** system data error .

Choose **【TEMPERATURE】** LED working temperature

Choose **【VERSION】** software version

Choose **【NETWORK PARA】** check network specification

Choose **【RDM】** check the fixture ID

Choose **【LABEL】** check model name

3.9 MANUAL



- Select **【RESET】** from the **【MANUAL】** menu
- **【ALL RESET】** menu, select **【YES/NO】** to carry out full fixture reset
- **【PT RESET】** menu, select **【YES/NO】** to carry out PAN/TILT reset

CHANNEL	VALUE	FUNCTION	SINGLE POINT CONTROL FUNCTION
	68 ↔ 71	static 16	1,2,3
	72 ↔ 45	static 17	1,4,5
	76 ↔ 79	static 18	1,6,7
	80 ↔ 83	static 19	1,2,5
	84 ↔ 87	static 20	1,3,6
	88 ↔ 91	static 21	1,4,7
	92 ↔ 95	static 22	3,5,7
9	96 ↔ 99	static 23	5,6,7
	100 ↔ 103	static 24	1,3,5,7
	104 ↔ 107	static 25	1,5,6,7
	108 ↔ 111	static 26	1,2,4,5,7
	112 ↔ 115	static 27	1,2,3,5,6
	116 ↔ 119	static 28	1,3,4,6,7
	120 ↔ 123	static 29	2,3,4,5,6,7
	124 ↔ 127	black	DARK
	128 ↔ 135	static ALL	BRIGHT
	136 ↔ 145	RING1 slow->fast	(2)-(3)-(4)-(5)-(6)-(7)
	146 ↔ 155	RING2A slow->fast	(2,3)-(4,5)-(6,7)
	156 ↔ 165	RING2B slow->fast	(2,5)-(3,6)-(4,7)
	166 ↔ 175	RING2C slow->fast	(1,2)-(1,3)-(1,4)-(1,5)-(1,6)-(1,7)
	176 ↔ 185	RING3A slow->fast	(2,3,4)-(5,6,7)
	186 ↔ 195	RING3B slow->fast	(1,2,3)-(1,4,5)-(1,6,7)
	196 ↔ 205	RING3C slow->fast	(1,2,5)-(1,3,6)-(1,4,7)
	206 ↔ 215	RING3D slow->fast	(2,5,7)-(1,4,6)
	216 ↔ 225	RING3E slow->fast	(2,3,4)-(3,4,5)-(4,5,6)-(5,6,7)-(6,7,2)-(7,2,3)
	226 ↔ 235	RING4 slow->fast	(1,2,3,5,6)-(1,3,4,6,7)-(1,4,5,7)
	236 ↔ 245	RING5 slow->fast	(1,2,3,5,6)-(1,3,4,6,7)-(1,4,5,7,2)
	246 ↔ 255	GINR6 slow->fast	(1)-(2,3,4,5,6,7)

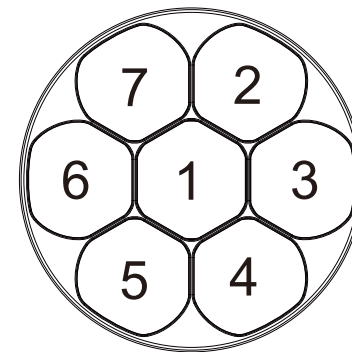

To identify up, middle and down by head which after the fixture electrify & reset

PERSON1

CHANNEL	VALUE	FUNCTION	SINGLE POINT CONTROL FUNCTION
1	0 ↔ 255	PAN	
2	0 ↔ 255	TITL	
3	0 ↔ 255	RED	
4	0 ↔ 255	GREEN	
5	0 ↔ 255	BLUE	
6	0 ↔ 255	WHITE	
7	0 ↔ 255	DIMMER	
8		MARCOS	
	0 ↔ 9	NO FUNCTION	
	10 ↔ 29	RED 100% / GREEN UP / BLUE 0%	
	30 ↔ 49	RED DOWN / GREEN 100% / BLUE 0%	
	50 ↔ 69	RED 0% / GREEN 100% / BLUE UP	
	70 ↔ 89	RED 0% / GREEN DOWN / BLUE 100%	
	90 ↔ 109	RED UP / GREEN 0% / BLUE 100%	
	110 ↔ 129	RED 100% / GREEN 0% / BLUE DOWN	
	130 ↔ 149	RED 100% / GREEN UP / BLUE UP	
	150 ↔ 169	RED DOWN / GREEN DOWN / BLUE 100%	
	170 ↔ 189	ALL LED AT FULL OUTPUT	
	190 ↔ 199	2700K	
	200 ↔ 209	3200K	
	210 ↔ 219	4200K	
	220 ↔ 229	5600K	
	230 ↔ 239	6500K	
240 ↔ 255	8000K		
9		A SINGLE POINT	
	0 ↔ 7	NO FUNCTION	
	8 ↔ 11	static 1	1
	12 ↔ 15	static 2	2
	16 ↔ 19	static 3	3
	20 ↔ 23	static 4	4
	24 ↔ 27	static 5	5
	28 ↔ 31	static 6	6
	32 ↔ 35	static 7	7
	36 ↔ 39	static 8	2,3
	40 ↔ 43	static 9	4,5
	44 ↔ 47	static 10	6,7
	48 ↔ 51	static 11	2,5
	52 ↔ 55	static 12	3,6
	56 ↔ 59	static 13	4,7
	60 ↔ 63	static 14	2,3,4
64 ↔ 67	static 15	5,6,7	

3.10 SERVICE

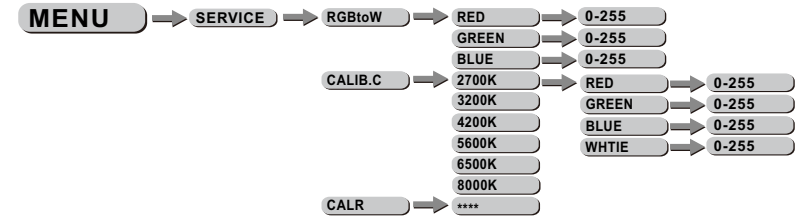

- Enter the **【RGBtoW】** to adjust the RGB parameter to make different whites.
- When the new setting is activated, the DMX controller choose RGB = 255,255,255 the white color will be made by the actual RGB values on the **【RGBtoW】**.
- Enter the **【CALIB】** to select white color of different color temperature.
- There are 11 pre-programmed White colors plus RGB TO WHITE and can be edited by using **【RED】**, **【GREEN】**, **【BLUE】** & **【WHITE】**.
- Press **【ENTER】** to find **【CALR】** CCT reset, press passcode (**Up + Down + Up + Down**), then **【SUCCESS】** will be shown

4 USING A DMX512 CONTROLLER

4.1 CHANNEL ASSIGNMENT

- Note: This product have four DMX512 channel configuration:
【HSIC】 , 【PERSON1】 , 【PERSON2】 , 【CMY】 , 【PIXEL】 .

HSIC

CHANNEL	VALUE	FUNCTION
1	0 ⇔ 255	PAN
2	0 ⇔ 255	PAN FINE
3	0 ⇔ 255	TITL
4	0 ⇔ 255	TITL FINE
5	0 ⇔ 255	PT SPEED
6	0 ⇔ 255	INTENSIYT
7	0 ⇔ 255	HUE
8	0 ⇔ 255	HUE FINE
9	0 ⇔ 255	SATURATION
10		CCT
	0 ⇔ 9	NO FUNCTION
	10 ⇔ 40	2700K
	41 ⇔ 80	3200K
	81 ⇔ 120	4200K
	121 ⇔ 160	5600K
	161 ⇔ 200	6500K
	201 ⇔ 255	8000K
11		STROBE
	0 ⇔ 9	NO FUNCTION
	10 ⇔ 99	STROBE FROM (SLOD TO FAST , 0-25Hz)
	100 ⇔ 109	NO FUNCTION
	110 ⇔ 179	LIGHTNING STROBE
	180 ⇔ 189	NO FUNCTION
	190 ⇔ 255	RANDOM SROBE
12	0 ⇔ 255	ZOOM

CHANNEL	VALUE	FUNCTION
13		CONTROL
	0 ⇔ 9	NO FUNCTION
	10 ⇔ 19	PAN/TILT BLACK ACTIVATED
	20 ⇔ 29	PAN/TILT BLACK DEACTIVATED
	30 ⇔ 39	FAN SLOW
	40 ⇔ 49	FAN NORMAL
	50 ⇔ 59	FAN FAST
	60 ⇔ 69	FAN AUTO
	70 ⇔ 79	AUTO1
	80 ⇔ 89	AUTO2
	90 ⇔ 99	CUSTOM
	100 ⇔ 109	TEST
	110 ⇔ 119	RESET
	120 ⇔ 129	NO FUNCTION
	130 ⇔ 139	DIM0
	140 ⇔ 149	DIM1
	150 ⇔ 159	DIM2
	160 ⇔ 169	DIM3
170 ⇔ 179	DIM4	
180 ⇔ 255	NO FUNCTION	