

PROFESSIONAL SOUND SYSTEMS >>>

TitanTM Series

OPERATING MANUAL AND USER GUIDE

TitanTM 8 Passive
TitanTM 12 Passive
TitanTM 15 Passive
TitanTM 8 Active
TitanTM 12 Active
TitanTM 15 Active
TitanTM Sub A12
TitanTM Sub A15



www.wharfedalepro.com

IMPORTANT WARNINGS & SAFETY INSTRUCTIONS - GENERAL

1. **READ ALL INSTRUCTIONS** carefully and become familiar with the features and functions of these products before operating them.
2. **RETAIN THESE INSTRUCTIONS** for future reference.
3. **COMPLY WITH ALL WARNINGS** – All warnings and instructions for this product should be adhered to.
4. **USE WITH AMPLIFIERS** – In order to avoid damage to drivers and other equipment, it is advisable to establish and follow a routine for powering up and powering down a sound system. With all system components connected, turn on source equipment (mixers, signal processors, record and playback units, etc.) **BEFORE** powering up amplifiers. Transient voltages from powering up source equipment can damage speakers if amplifiers are already turned on. Make sure that amplifier volumes are set to their minimum settings and power up any system amplifiers **LAST**. It is recommended that all system components be allowed to stabilize for several seconds before any source signals are introduced or level setting adjustments are made. Similarly, when shutting systems down, turn all amplifiers off first, before powering down any other system components. This also applies to active or self-powered speakers, Switch them on **LAST** and off **FIRST**.
5. **CABLES** – Do not use shielded or microphone cables for connection between amplifiers and speakers. Use only approved speaker cables with proper connectors.
6. **RIGGING – SUSPENDING – MOUNTING** – Rigging, suspending and mounting of these speaker systems can expose members of the public to serious health risks and even death. **UNDER NO CIRCUMSTANCES ATTEMPT TO RIG, SUSPEND OR OTHERWISE MOUNT THESE SPEAKERS UNLESS YOU ARE FULLY QUALIFIED AND CERTIFIED TO DO SO BY RELEVANT LOCAL, STATE AND NATIONAL AUTHORITIES. ALL RELEVANT SAFETY REGULATIONS MUST BE FOLLOWED. IF YOU ARE NOT PROPERLY QUALIFIED OR DO NOT KNOW OF PERTINENT REGULATIONS, CONSULT QUALIFIED PERSONNEL FOR ADVICE.**
7. **CAUTION** – These professional loudspeaker systems are capable of generating very high sound pressure levels. Use care with placement and operation to avoid exposure to excessive volume levels. Permanent hearing damage can result when operated to extreme levels.
8. **SERVICE** – There are no user serviceable parts inside this product. Users should not attempt to service this product. Warranty nullification could result if this is attempted.

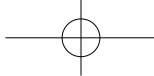

Wall Mounting Titan Speaker System

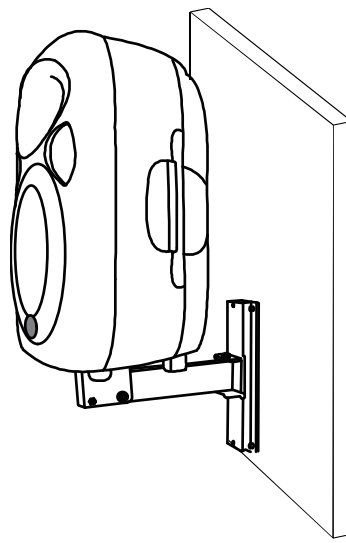

WPB-1 Wall Mounting Bracket (Titan™ 12 / 15)

WHARFEDALE PRO LIMITED WARRANTY

Wharfedale Pro Titan™ Series speakers are warranted of manufacturing or material defects for a period of one year from the original date of purchase. In the event of malfunction, contact your authorized Wharfedale Pro dealer or distributor for information.

*Be aware that warranty details may differ from country to country. Contact your dealers or distributor for information. These terms do not infringe your statutory rights.

TABLE OF CONTENTS

- 1.....Important Warnings & Safety Instructions
- 2.....Important Safety Information Powered Products
- 4.....What about the Titan™ Series?
- 5.....Introduction/Overview
- 6.....Features
- 7.....Setting up/ Speaker Placement
- 7.....Connections/ Wiring - Passive
- 8.....Rear Panel Layout - Passive
- 8.....Connection Diagram Passive
- 12.....Rear Panel Layout - Active
- 15.....Connection Diagram Active
- 16.....Rear Panel Layout - Sub A12
- 17.....Connection Diagram Sub A12
- 19.....Rear Panel Layout - Sub A15
- 20.....Connection Diagram Sub A15
- 22.....Specifications - Titan™ Passive
- 23.....Specifications - Titan™ Active
- 25.....Specifications - Titan™ Subwoofers
- 26.....Dimensional Drawings - Titan™ 8/ 12
- 27.....Dimensional Drawings - Titan™ 15/ 8A
- 28.....Dimensional Drawings - Titan™ 12A / 15A
- 29.....Dimensional Drawings - Titan™ Sub A12/A15
- 30.....Wall Mounting Titan Speaker System
- 30.....Warranty

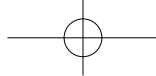

DIMENSIONS

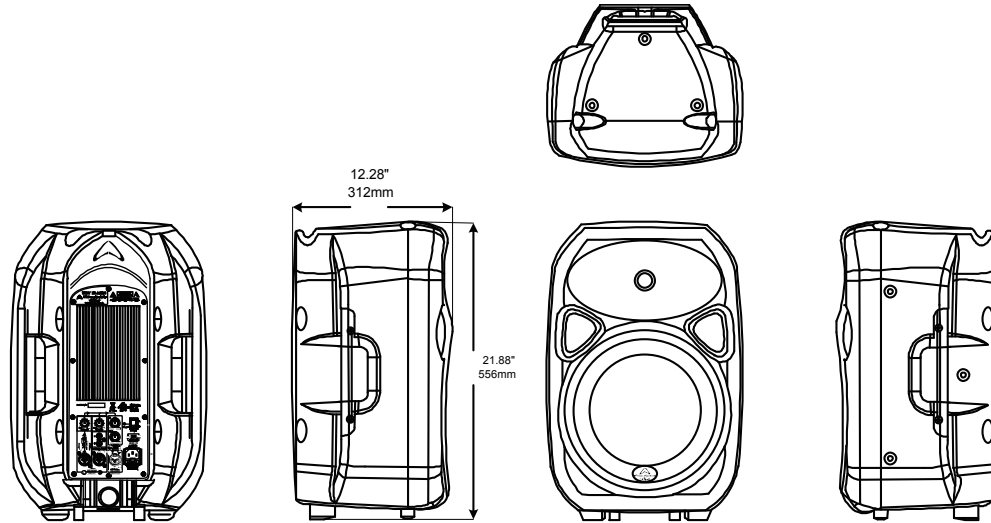

Titan™ 12 A

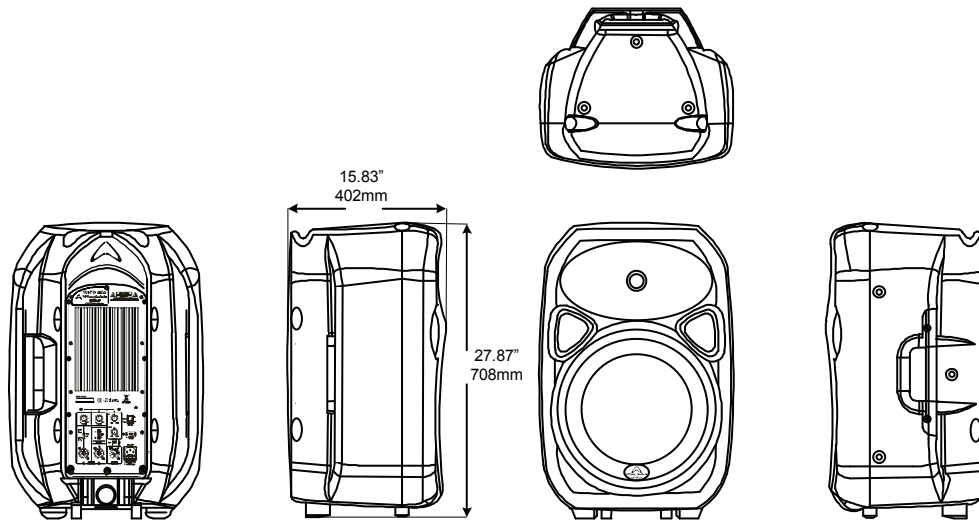
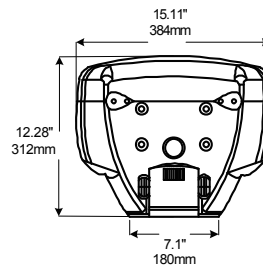

Titan™ 15 A

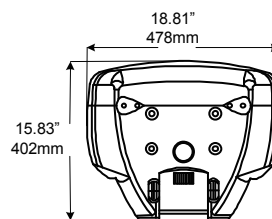

TITAN™ SERIES OVERVIEW

The Titan™ Series are powerful, accurate, high quality loudspeaker systems with low distortion that were designed to deliver high quality sound for the best value. From the Titan™ 8 (passive) to the Titan™ 15 Active models plus two powered subs, you have what it takes to assemble the system that your music deserves.

An important factor in loudspeakers is the smoothness of the sound coverage. Many speakers that may sound acceptable in the horizontal plane have problems in the vertical plane. Due to an integral high frequency Elliptical Wave Guide (EWG), the Titan™ speakers exhibit very smooth and well behaved sound dispersion characteristics in both the horizontal and vertical planes making positioning and set-up less critical. Everyone in the room will hear the same quality sound.

The Titan™ Active Series has many features to allow you greater flexibility in your sound: "BRO™ " Bass Response Optimizer circuit, when engaged, allows for enhanced low frequency response at lower volume levels. This is very similar to a loudness switch on your home stereo amplifier.

Starting with the Titan™ 12 Active speaker, two-band EQ (equalization) is added. These tone controls provide +/-10dB in each frequency range.

Sometimes, in live performance, it is not easy to know if your speakers are working or not; they may be ahead of you when performing or they are not so close to you. To remedy this problem, there is a POWER 'ON' indicator LED on the back panel as well as in the throat of the horn to give you a visual indication that there is power to the speaker. There is also a LIMIT indicator LED on the back panel. The LIMIT LED illuminates when the signal limiter is actively limiting the level of the signal to prevent distortion and overload.

The Titan™ Series rugged cabinet features moulded in handles, feet, cord wrap and cable anchors moulded into the lightweight Polypropylene cabinet. It also accommodates a bottom mounted OmniMount® 60.0 bracket for wall mounting.

To make installation easier and safe, mounting and hanging brackets are available. The diagrams at the end of this manual have rigging / hanging suggestions to get the most out of your system.

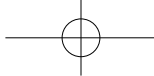

DIMENSIONS

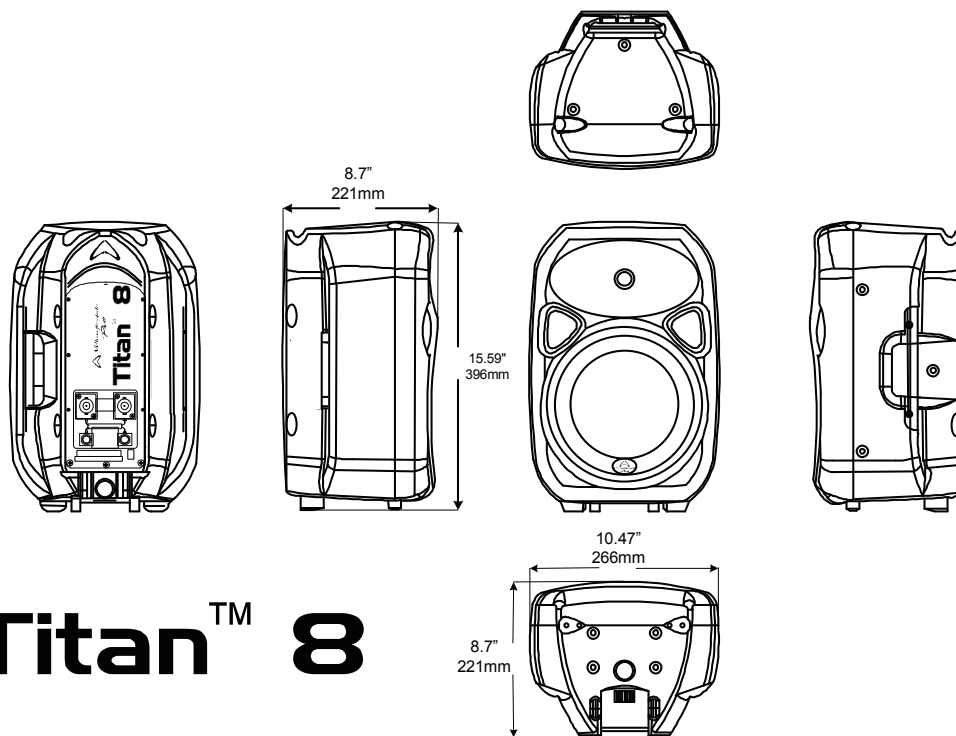

Titan™ 8

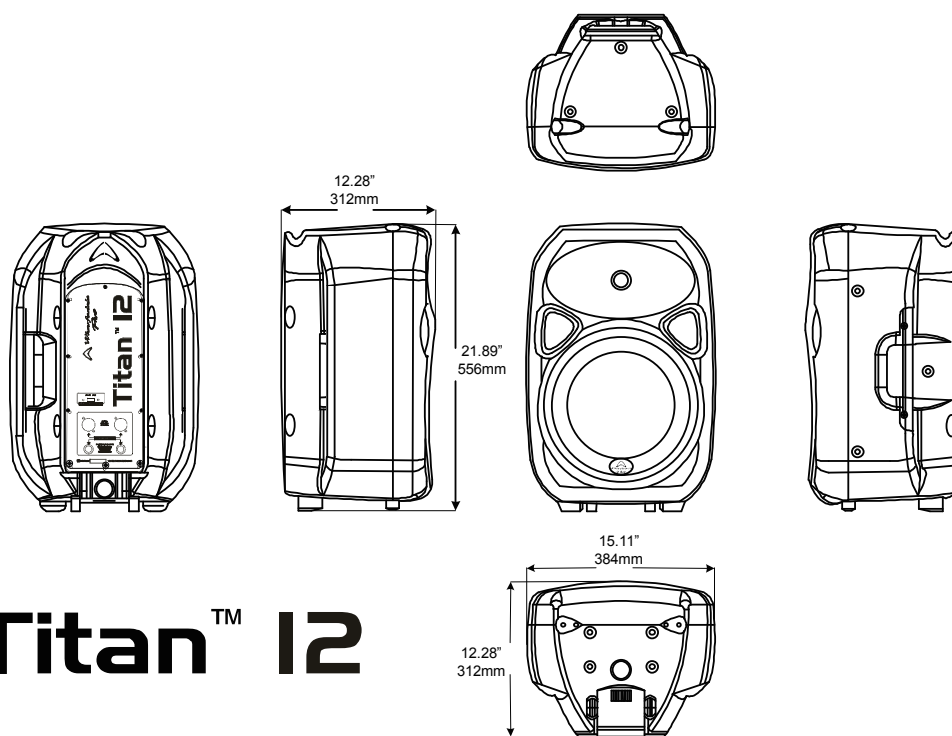

Titan™ 12

SETTING UP/ SPEAKER PLACEMENT

The uniform dispersion of the Titan™ Series makes it easy to place the speakers where you need them, rather than trying to rearrange the room to accommodate the sound system. For the best coverage and highest quality sound, the speakers should be located above head level. Mounting hardware (M6/M8) and an integral tripod stand socket make installation easy and safe. The Titan™ Series accommodates a bottom mounted OmniMount® 60.0 (Titan™ 12, 15) and OmniMount® 30.0 (Titan™ 8) bracket and has optional rigging / hanging brackets.

Before turning on the Titan™ Series, or any powered loudspeaker, be sure that the power switch is in the off position, volume controls are all the way down (at 0 level) and all audio connections are made.

After power-up, speak into your mic or start the CD or MP3 player or other line level device and slowly increase the volume to the desired level. Always remember that a speaker will do what you tell it to do (i.e. deliver sound to the audience), but if the audience is too large and your system too small, you will not achieve the desired sound level without a lot of distortion. Avoid distortion as it can damage your speakers in the long term. If you cannot achieve the desired SPL, you must add more speakers or a subwoofer to the system.

CONNECTIONS/ WIRING

Titan™ 8 / Titan™ 12 / Titan™ 15 Passive

Connecting the Titan™ Series to your system is easy. The rear panels include NL4 and 1/4" phone connectors in parallel. Run your speaker wires from your amplifier to the speaker. You can use either input connector. Use the correct gauge of speaker cable according to the power handling ability of your Titan™ Series cabinet. Use stranded insulated cable for speaker runs. It is always advisable to use heavier gauge (lower number) cables on longer runs. Be sure to connect your speakers in proper polarity (what many refer to erroneously, as phase). This means that in normal operation; connect one end of the same wire to the Red terminal on the amplifier and the other end to the + (tip) connector on the speaker. Black is always the ground or common.

Although the location of the speakers is not often critical to your sound, there are some guidelines to follow, especially with powered speakers, to make the sound the best it can be.

- Try to plug the amplifiers (a/k/a powered speakers) into a circuit that does not have light dimmers or refrigerators on it. When these devices are in the circuit, it is almost certain you will get a 50Hz hum in your system that cannot be removed with a EQ.
- Make sure the speakers are above head level to make the projection of the sound as good as it can be. Keep the speakers out of the corner of the room. Place them away from boundaries and the microphones. Do not place them too far apart.
- When using the hanging bracket or another apparatus, use a cable safety line attached to the speaker and a solid part of the wall - not the bracket. If the bracket fails, the speaker will not fall down.
- If the speakers will be hanging above the audience, it often is a good idea to turn the speakers upside down and aim the horn 2/3 of the way back in the room. This will provide good coverage of the audience.

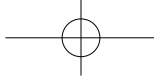

SPECIFICATIONS - Titan™ ACTIVE (Con't)

| | Titan™ 8 ACTIVE | Titan™ 12 ACTIVE | Titan™ 15 ACTIVE |
|---|---|---|---|
| Inputs | | | |
| Input A – type | Switchable balanced mic or line level input | Switchable balanced mic or line level input | Switchable balanced mic or line level input |
| Input Sensitivity | Mic: -36dBu (-38.2dBv or 12.28mVrms) Line: +4dBu (1.78dBv or 1.228Vrms) | Mic: -36dBu (-38.2dBv or 12.28mVrms) Line: +4dBu (1.78dBv or 1.228Vrms) | Mic: -36dBu (-38.2dBv or 12.28mVrms) Line: +4dBu (1.78dBv or 1.228Vrms) |
| Maximum Input Level | +22dBu | +22dBu | +22dBu |
| Input Connector | XLR - 1/4" Combo jack | XLR - 1/4" Combo jack | XLR - 1/4" Combo jack |
| Input Impedance | Balanced: 20k ohms | Balanced: 20k ohms Unbalanced: 10k ohms | Balanced: 20k ohms Unbalanced: 10k ohms |
| Maximum Input Level | +22dBu | +22dBu | +22dBu |
| Input B – type | | Line level input | Line level input |
| Input Sensitivity | | XLR - 1/4" Combo jack: 1.78dBv or 1.228Vrms RCA: 0dBu (-2.2dBv or 0.775Vrms) | XLR - 1/4" Combo jack: 1.78dBv or 1.228Vrms RCA: 0dBu (-2.2dBv or 0.775Vrms) |
| Maximum Input Level | | +22dBu | +22dBu |
| Input Connectors | | Combo jack: 1/4" - XLR / Summed | Combo jack: 1/4" - XLR / Summed dual RCA jacks |
| Line Output | | | |
| Line Output Connector | | Switchable LOOP / MIX Balanced Male XLR | Switchable LOOP / MIX Balanced Male XLR |
| Impedance: | | Balanced: 1k ohm Unbalanced: 500 ohm | Balanced: 1k ohm Unbalanced: 500 ohm |
| Sensitivity | | +4dBu (1.78dBv or 1.228Vrms) | +4dBu (1.78dBv or 1.228Vrms) |
| AC Power details | | | |
| Power Supply | High Efficiency Switching Mode Power Supply | High Efficiency Switching Mode Power Supply | High Efficiency Switching Mode Power Supply |
| AC Power Options | AC100~120V / 220~240V, 50 / 60Hz | AC100~120V / 220~240V, 50 / 60Hz | AC100~120V / 220~240V, 50 / 60Hz |
| Power On Indicator | LED | LED | LED |
| Rigging / Bracket / Mounting Options | 8 M6 threaded inserts including 4 M6 threaded inserts on bottom in OmniMount 30.0-type footprint Pole-mount receptacle with lock screw 1 carry handles (on each side) Optional wall-mount bracket | 10 M8 threaded inserts including 4 M8 threaded inserts on bottom in OmniMount 60.0-type footprint Pole-mount receptacle with lock screw 2 carry handles (one on each side) Optional wall-mount bracket | 10 M8 threaded inserts including 4 M8 threaded inserts on bottom in OmniMount 60.0-type footprint Pole-mount receptacle with lock screw 2 carry handles (one on each side) Optional wall-mount bracket |
| Enclosure Material | Injection Moulded Polypropylene | Injection Moulded Polypropylene | Injection Moulded Polypropylene |
| Colours | Grey or white or black | Grey or white or black | Grey or white or black |
| Dimensions H x W x D (mm) | 396 x 266 x 221 | 556 x 384 x 312 | 708.3 x 477.8 x 401.8 |
| Dimensions H x W x D (in) | 15.6 x 10.5 x 8.7 | 21.9 x 15.1 x 12.3 | 27.9" x 18.8" x 15.8 |
| Net Weight (kg / lbs) | 5.7kg / 12.54lbs | 12.8kg / 28.16lbs | 23.94kg / 52.67lbs |
| Gross Weight (kg / lbs) | 7.70kg / 16.94lbs | 14.8kg / 32.56lbs | 26.94kg / 59.27lbs |

OPERATING MANUAL AND USER GUIDE

CONNECTION DIAGRAM # 2

**Titan™ 8/12/15 MONO SYSTEM
WITH TWO MONITORS**

**CONNECTING MULTIPLE
Titan™ 8/12/15 SPEAKERS TOGETHER
IN A MONO-MAIN AND STAGE
MONITOR CONFIGURATION USING A
SINGLE, DUAL CHANNEL AMPLIFIER**

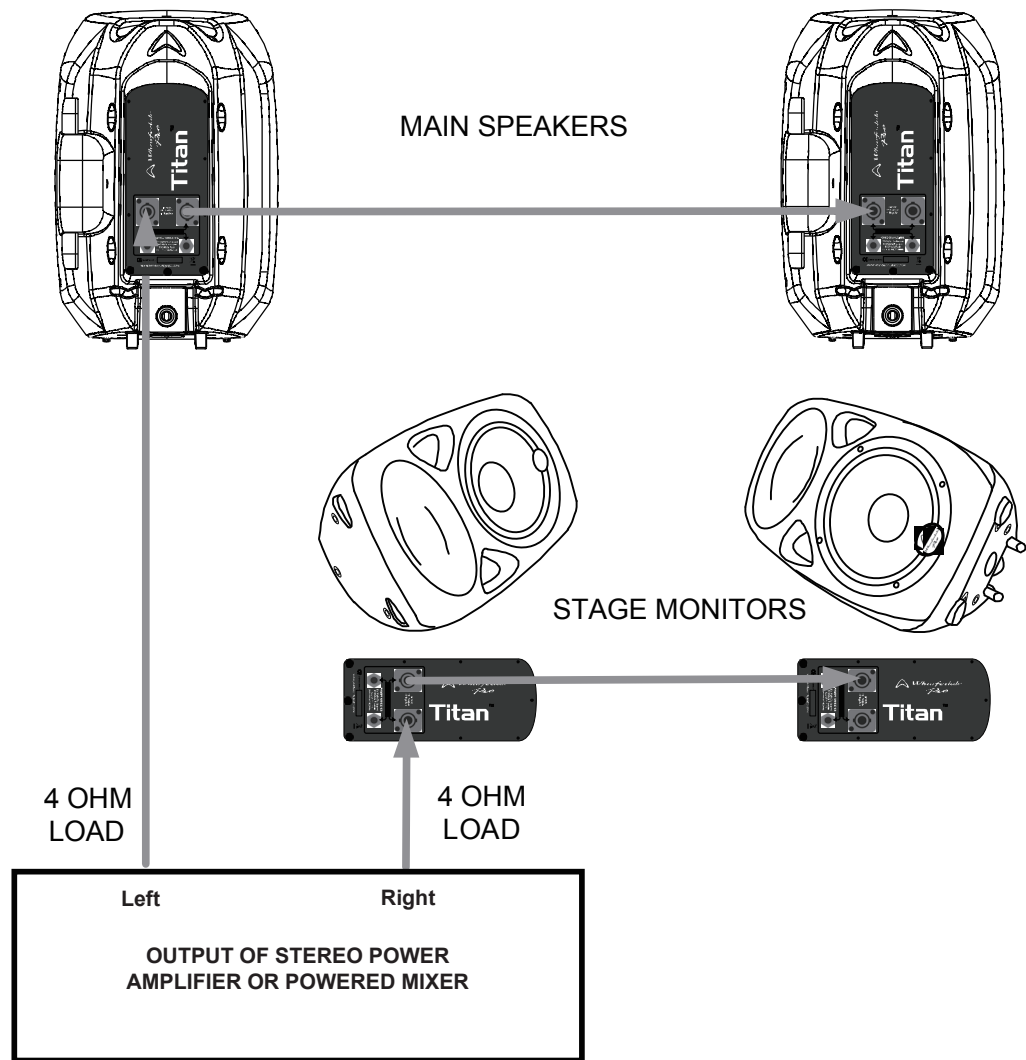

NOTE: This configuration represents a 4 ohm load to each output channel of the amplifier.

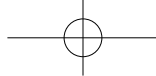

SPECIFICATIONS - Titan™ PASSIVE SERIES

| | Titan™ 8 | Titan™ 12 | Titan™ 15 |
|-------------------------------------|---|---|---|
| Loudspeaker Type: | 8" 2-way | 12" 2-way | 15" 2-way |
| Frequency Response (+/-3dB): | 70 - 20kHz | 55 - 20kHz | 50 - 20kHz |
| Sensitivity (1W@1M): | 96dB | 98dB | 97dB |
| Peak SPL: | 124dB | 128dB | 129dB |
| HF Coverage (H x V): | 90° x 60° | 90° x 60° | 90° x 60° |
| System Impedance: | 8 ohm | 8 ohm | 8 ohm |
| POWER (WATTS) | | | |
| Continuous: | 150W | 250W | 400W |
| Music: | 300W | 500 | 800W |
| Peak: | 600W | 1000 | 1600W |
| LF DRIVER | | | |
| Size: | 203mm/ 8" | 305mm/ 12" | 381mm/ 15" |
| Coil Size: | 38.86mm / 1.53" | 64.26mm / 2.5" | 75mm / 3.0" |
| HF DRIVER/ HORN | Compression Driver | Compression Driver | Compression Driver |
| Coil Size: | 25mm/1" | 44mm/1.75" | 51mm/ 2.0" |
| Exit Size: | 30mm/1.2" | 25mm/1" | 25mm/1" |
| Diaphragm Material: | Cloth | Titanium | Titanium |
| HF Driver Protection: | Bulb | DTF™ Dynamic Thermal Filament | DTF™ Dynamic Thermal Filament |
| Long-Throw EQ Compensation: | N/A | 3dB boost (long-throw) / Flat (near-field) EWG™ - Elliptical Waveguide | N/A |
| Horn Type: | EWG™ - Elliptical Waveguide | | |
| Throat Size: | 25mm/1" | 25mm/1" | 25mm/1" |
| CROSSOVER | | | |
| Type/Frequency/Filter: | 2-way 2.4KHz / Linkwitz-Riley | 2-way 2.2KHz / Linkwitz-Riley | 2-way 1.8KHz / Linkwitz-Riley |
| ENCLOSURE | | | |
| Shape/ Material: | Trapezoidal/ Polypropylene | Trapezoidal/ Polypropylene | Trapezoidal/ Polypropylene |
| Rigging: | (8) M6 threaded rigging points + (4) M6 threaded rigging points on bottom in Omnimount® 30.0-type footprint + Speaker pole-mount receptacle with lock screw + 1 built-in carry handle + Optional wall-mount bracket + Optional dual-unit array speaker stand hardware | (10) M8 threaded rigging points + (4) M8 threaded rigging points on bottom in Omnimount® 60.0-type footprint + Speaker pole-mount receptacle with lock screw + Optional wall-mount bracket + Optional dual-unit array speaker stand hardware | (10) M8 threaded rigging points + (4) M8 threaded rigging points on bottom in Omnimount® 60.0-type footprint + Speaker pole-mount receptacle with lock screw + Optional wall-mount bracket + Optional dual unit array speaker stand hardware |
| COLOURS | Grey or Black or White | Grey or Black or White | Grey or Black or White |
| OUTPUT CONNECTORS | 2 x 1/4" jacks + 2 x NL4 | 2 x 1/4" jacks + 2 x NL4 | 2 x 1/4" jacks + 2 x NL4 |
| DIMENSIONS/WEIGHTS | | | |
| Weight: | 5.5kg / 12.1lbs | 12kg / 26.4lbs | 22kg / 48.4lbs |
| Dimensions (H x W x D): | 396 x 266 x 221mm/ 15.59" x 10.47" x 8.7" | 556 x 384 x 312mm/ 21.88" x 15.1" x 12.3" | 708.3 x 477.8 x 401.77mm/ 27.9" x 18.8" x 15.8" |

CONNECTION DIAGRAM # 4

USING THE Titan™ 8/12/15 WITH A PASSIVE SUBWOOFER

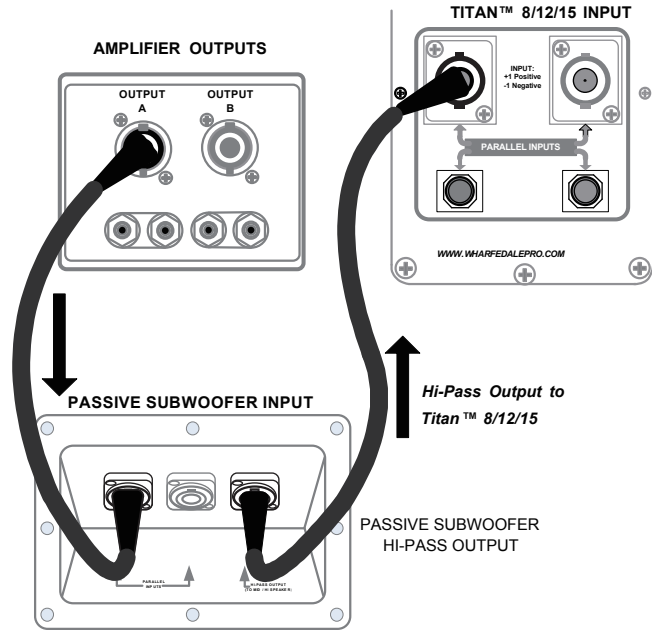

CONNECTION DIAGRAM # 5

USING THE Titan™ 8/12/15 IN A BI-AMP SYSTEM

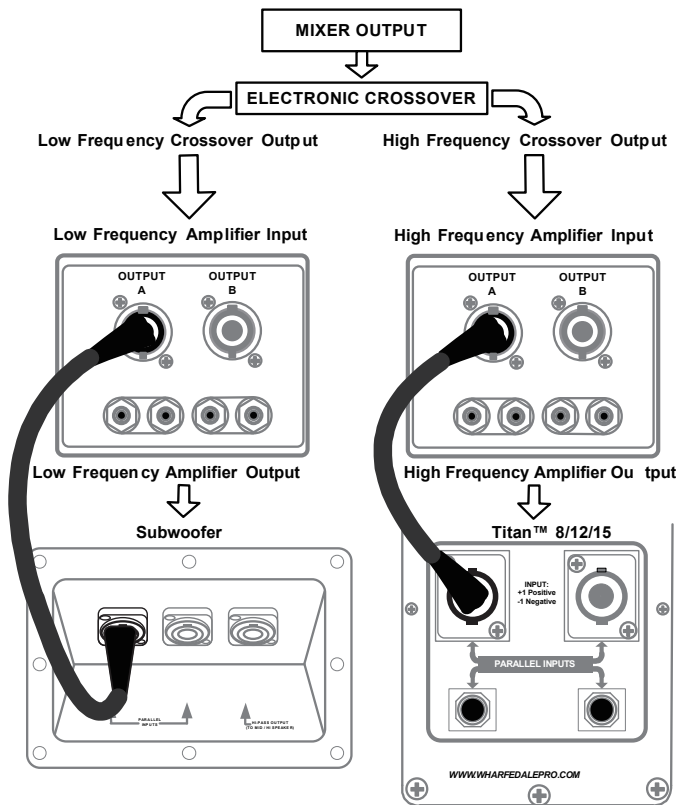

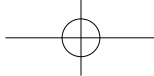

CONNECTION DIAGRAM # 1

**TWO CHANNEL SYSTEM WITH
HIGHPASS OUTPUT**

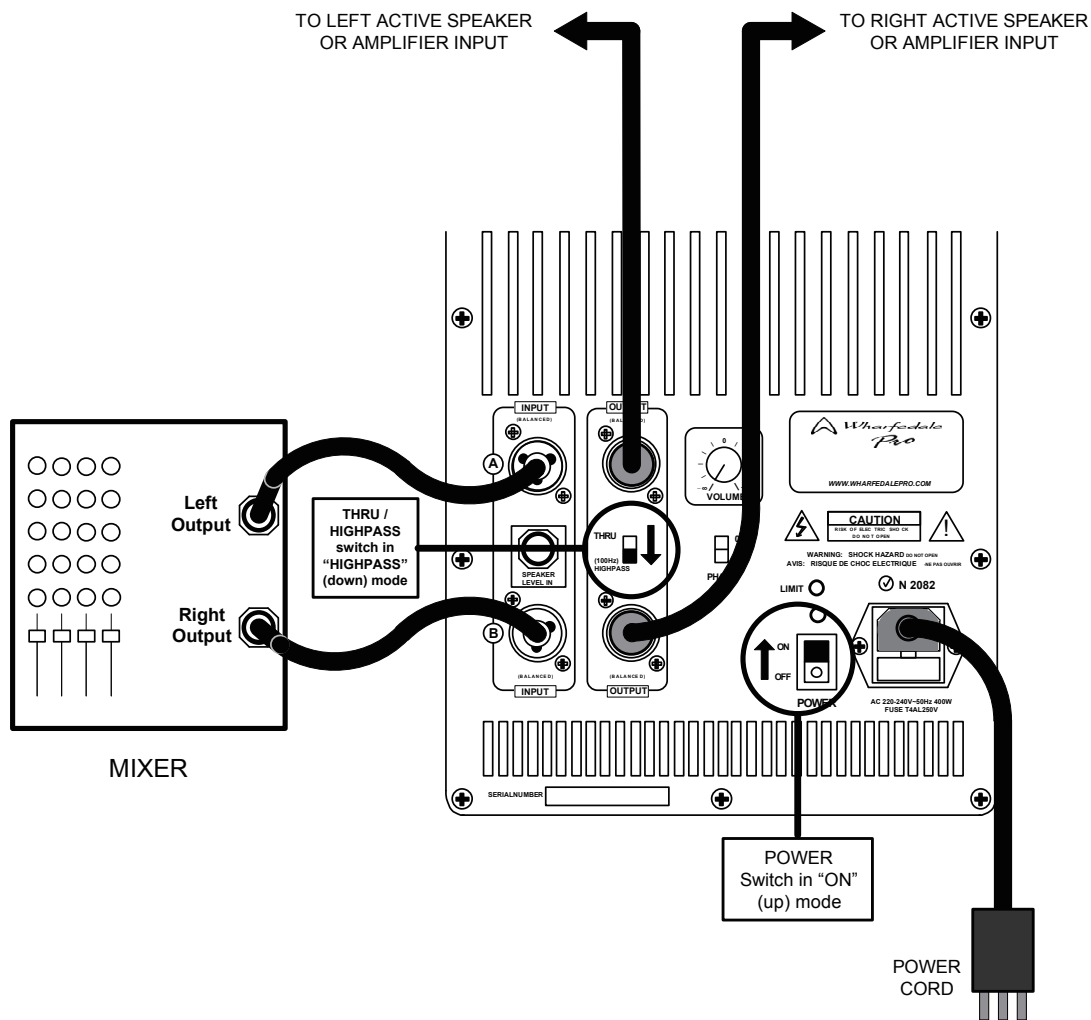

NOTE: This same connection configuration can be used with OUTPUT A and B used in a full-range mode when the THRU/HIGHPASS switch is in the "THRU" (up) position.

OPERATING MANUAL AND USER GUIDE

Titan™ 12/15 ACTIVE REAR PANEL LAYOUT

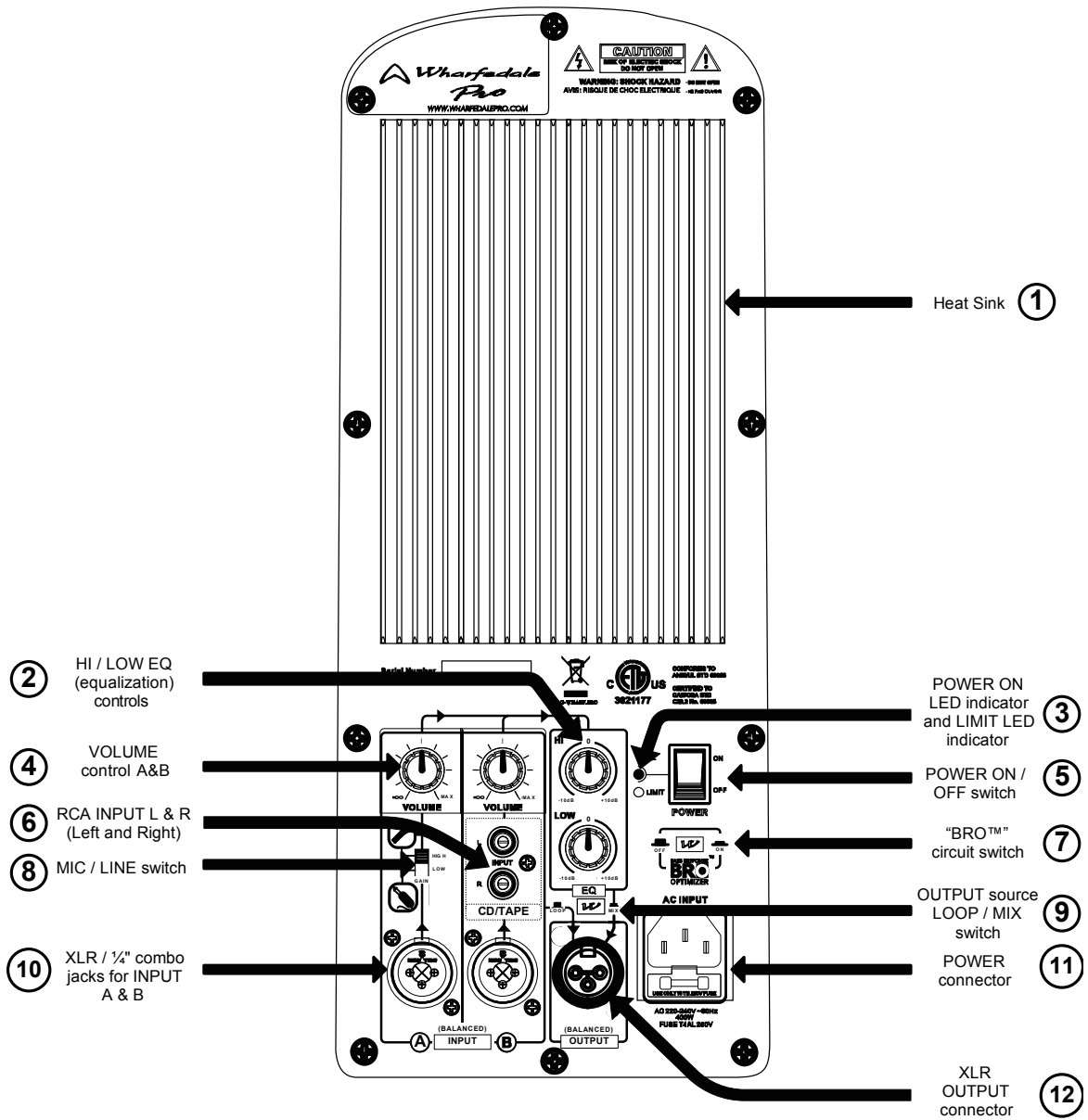

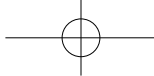

Titan™ Sub-A12 CONNECTION DIAGRAM # 2

USING TWO Titan™ Sub-A12 WITH TWO POWER SPEAKERS

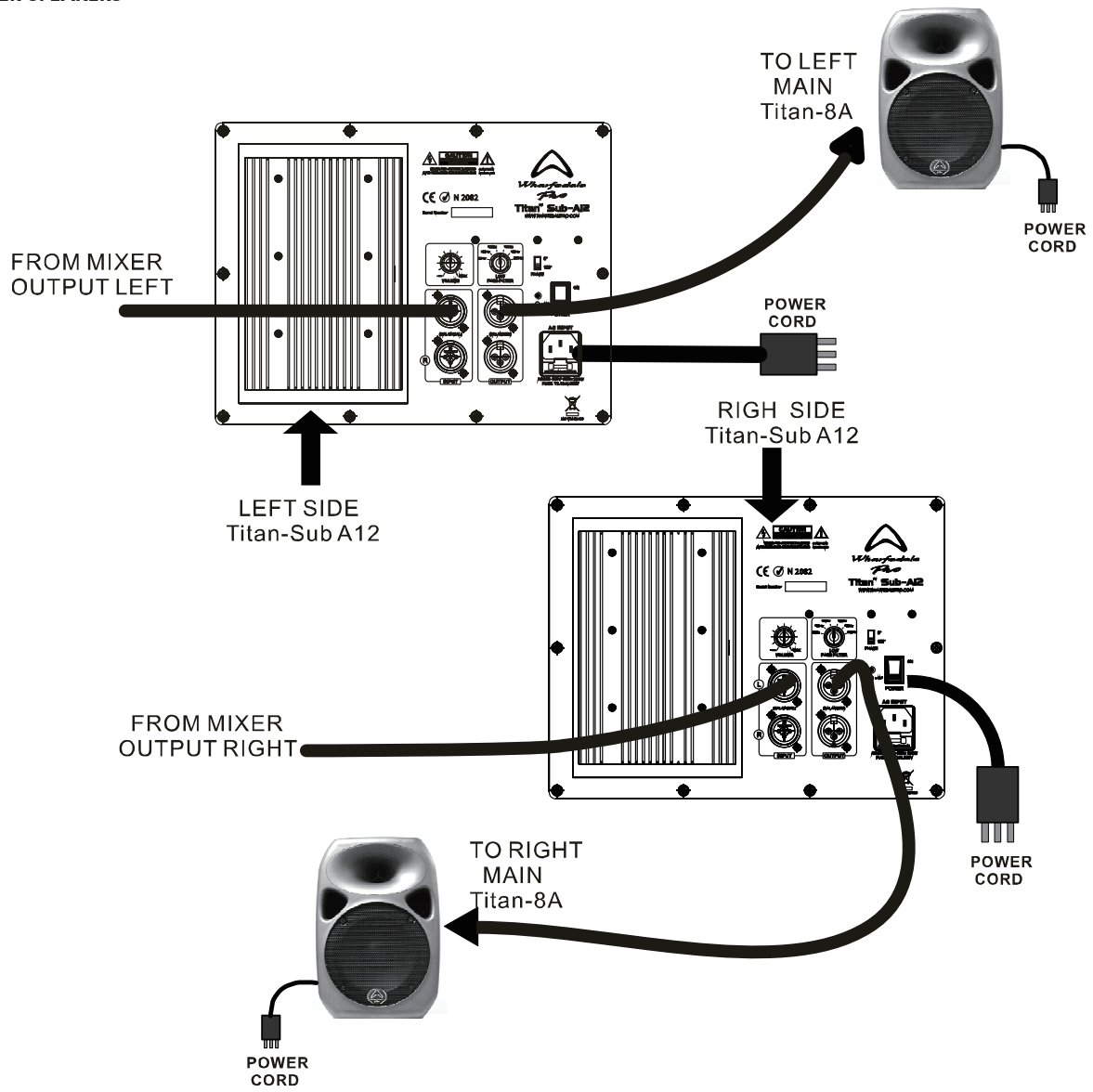

OPERATING MANUAL AND USER GUIDE

Titan™ 12A / 15A CONNECTION DIAGRAM # 1

Basic microphone / playback hookup

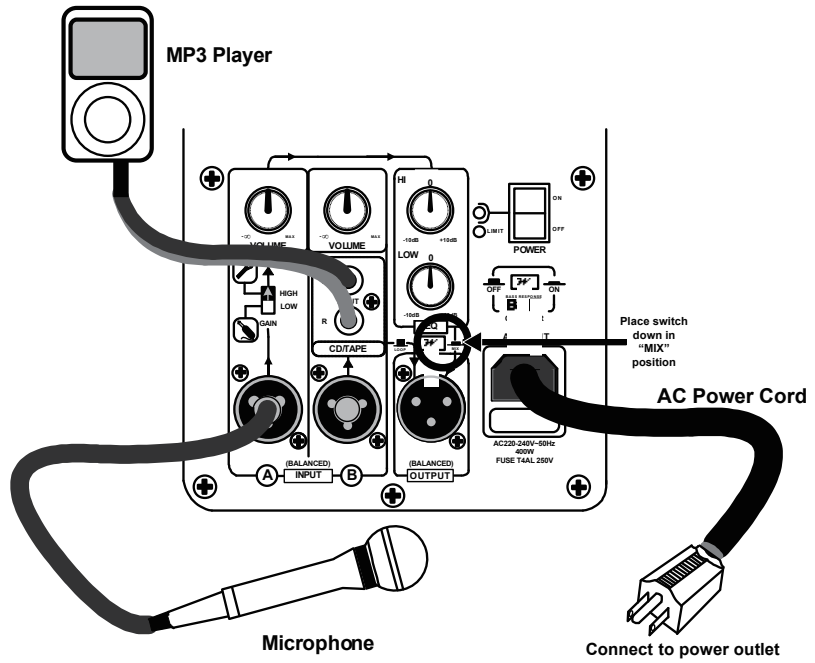

Titan™ 12A / 15A CONNECTION DIAGRAM # 2

Connecting two Titan™ 12 ACTIVE speakers together

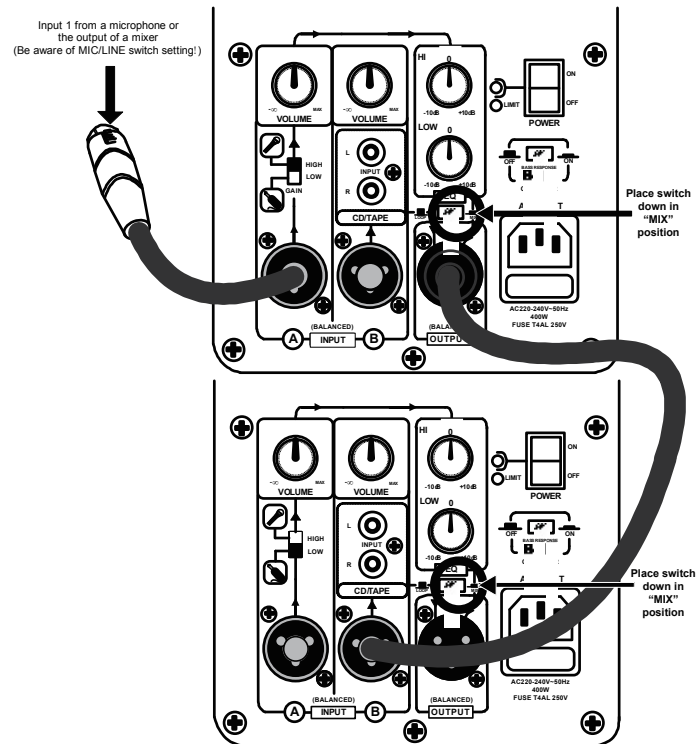



Titan™ Sub A12 Rear Panel Features

1. **HEAT SINK** - Cooling fins for amplifier. Do not obstruct.
2. **VOLUME CONTROL** - Adjusts the volume.
3. **INPUT L** - Balanced line level input via a XLR/ 1/4" combo connector.
4. **INPUT R** - Balanced line level input via a XLR/ 1/4" combo connector.
5. **OUTPUT R** - Balanced male XLR connector provides output HIGHPASS signal.
6. **OUTPUT L** - Balanced male XLR connector provides output HIGHPASS signal.
7. **POWER SOCKET** - This is the connection for the IEC AC power connector.
8. **LIMIT LED** - LED indicator illuminates when the signal limiting function is activated.
9. **POWER LED** - LED indicator illuminates when the unit is powered up
9. **POWER SWITCH** - Turns the power on and off to the subwoofer amplifier module.
10. **PHASE SWITCH** - Selects the polarity of the signal being sent to the subwoofer.
0° selects the signal polarity as it appears at the input.
The 180° selection inverts the polarity of the signal.
11. **CROSSOVER FREQUENCY CONTROL** - Adjustable 80Hz/100Hz/120Hz/150Hz/180Hz/200Hz.

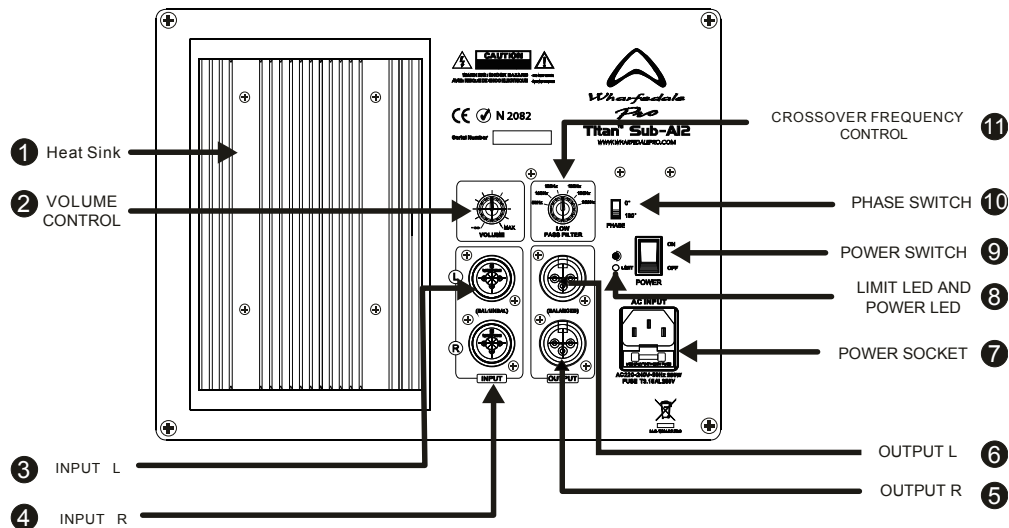

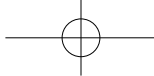

OPERATING MANUAL AND USER GUIDE

Titan™ Sub-A12 CONNECTION DIAGRAM # 1

TWO CHANNEL SYSTEM WITH HIGHPASS OUTPUT

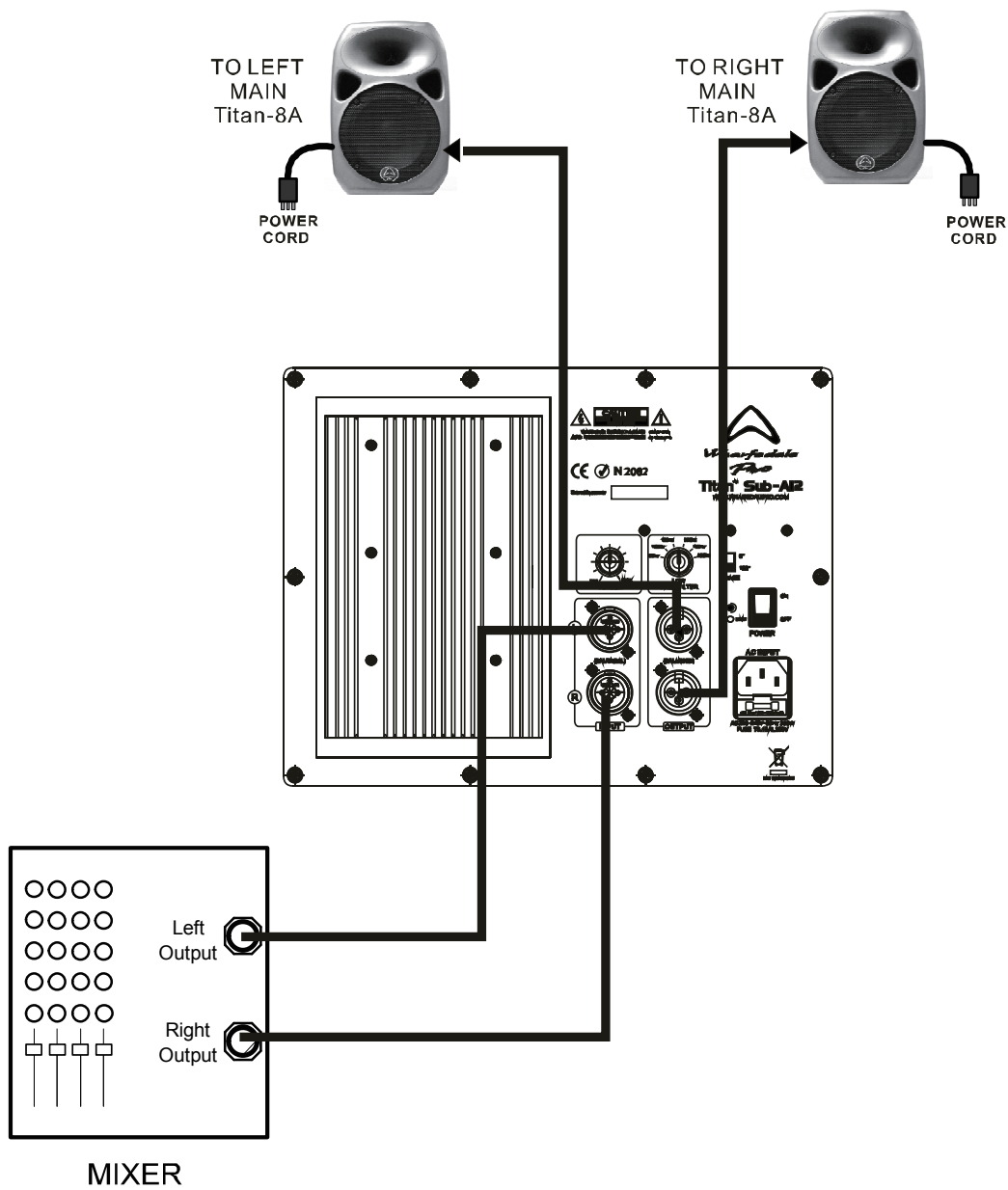

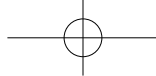

Titan™ 8/12/15 ACTIVE Rear Panel Features

- 1. Heat Sink:** The heat sink allows for dissipation of heat built up from the amplifier via air cooling at the rear of the enclosure.
- 2. HI and LOW EQ (equalization) controls:** These knobs control the equalization of the overall output signal providing +/- 10dB in each frequency range.
- 3. POWER 'ON' indicator LED and LIMIT indicator LED:** The bracketed LED to the left of the POWER switch illuminates when the power switch is in the 'ON' position. The LIMIT LED illuminates when the signal limiter is actively limiting the level of the signal to prevent distortion and overload.
- 4. VOLUME controls for INPUT A and INPUT B:** These knobs control the volume of each input channel (Titan™ 8 VOLUME controls is MAIN) .
- 5. POWER ON / OFF switch:** This switch: turns the power on and off.
- 6. RCA L / R (Left and Right) input jacks:** These jacks provide for the input of a stereo signal (left and right). The signal is actively combined or "summed" providing a mono signal to the amplifier.
- 7. "BRO™" Bass Response Optimizer circuit switch:** The BRO™ circuit, when engaged, allows for enhanced low frequency response at lower volume levels.
- 8. GAIN selection switch:** This switch selects the proper gain structure for INPUT A. If a microphone is connected to INPUT A, use the HIGH selection (up). If the signal source is anything other than a microphone (playback device, keyboard or mixer output, for instance) use the LOW selection (down) .
- 9. Output source "LOOP / MIX" switch:** In the "LOOP" mode, this switch routes the signal of INPUT B to the line level XLR OUTPUT jack, bypassing the EQ section and volume control. When in the MIX mode, this switch routes the combined (or "mixed") signals of both INPUT A and INPUT B to the line level XLR OUTPUT jack.
- 10. XLR / ¼" COMBO input jacks for INPUT A and INPUT B:** These convenient jacks provide for either XLR or ¼" balanced input connections to INPUT A and INPUT B (Titan™ 8 XLR ¼" COMBO input jacks for INPUT) .
- 11. POWER cord jack:** This is a jack for a standard IEC, three prong, grounded AC electrical connection cord. Be sure that you are plugging into the correct source voltage that matches what is indicated just below the power cord jack.
- 12. XLR line level OUTPUT jack:** This jack provides a balanced line level output of INPUT A and INPUT B signals (in MIX mode) or INPUT B signal only (in LOOP mode) for connection to additional Titan™ 12 / 15 ACTIVES, powered subwoofers or amplifiers.

Titan™ Sub-A15 - REAR PANEL FEATURES

1. **INPUT A** - Balanced line level input via a XLR / 1/4" combo connection.
2. **OUTPUT A** - Balanced male XLR connection provides output "THRU" or HIGHPASS signal (depending on switch setting).
3. **SPEAKER LEVEL INPUT** - Allows for connection of the output of an external amplifier to use the Titan™ Sub-A15 as a passivesubwoofer.
NOTE: Disconnect the power cord when using the Titan™ Sub-A15 in this mode.
4. **INPUT B** - Balanced line level input via a XLR / 1/4" combo connection.
5. **OUTPUT B** - Balanced male XLR connection provides output "THRU" or HIGHPASS signal (depending on switch setting).
6. **HEATSINK** - Cooling fins for amplifier. Do not obstruct.
7. **VOLUME CONTROL** - Adjusts volume level of the subwoofer.
8. **THRU / HIGHPASS SWITCH** - Selects the signal type that is routed to the OUTPUT jacks. "THRU" sends the unprocessed signal to the outputs. "HIGHPASS" filters the signal and only sends signals above 100Hz to the outputs.
9. **PHASE SWITCH** - Selects the polarity of the signal being sent to the subwoofer. 0° selects the signal polarity as it appears at the input. The "180°" selection inverts the phase of the signal.
10. **LIMIT LED** - LED indicator illuminates when the signal limiting function is activated.
11. **POWER LED** - LED indicator illuminates when the unit is powered up.
12. **POWER SOCKET** - This is the connection for the IEC AC power connector.
13. **POWER SWITCH** - Turns the power on and off to the subwoofer amplifier module.

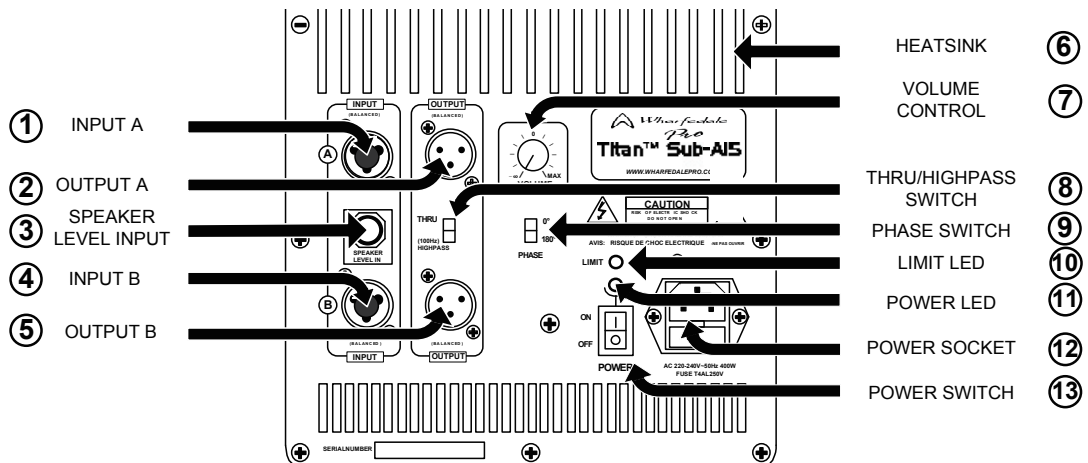

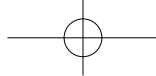

Titan™ 8 / Titan™ 12 / Titan™ 15 ACTIVE

Connecting the Titan™ Active Series to your system is just as easy, with a couple more things to do. Plug in the electrical cable and your audio cables and switch the unit on. Always be sure there is a good electrical ground. The Titan™ Series rear panel has one combo XLR / TRS Jack input. Be sure to use high quality shielded cable and high quality connectors. The volume control is conveniently located above the input sensitivity switch (mic/line). Be sure you have that switch in the correct position.

The Loop / Mix Switch - Titan™ 12A / 15A ONLY

The LOOP/MIX switch allows you to control the signal content going to the XLR OUTPUT jack. In the "LOOP" mode, this switch routes the signal of INPUT B to the line level XLR OUTPUT jack, bypassing the EQ section and volume control. When in the MIX mode, this switch routes the combined (or "mixed") signals of both INPUT A and INPUT B to the line level XLR OUTPUT jack. This signal can then be sent to additional powered speakers or powered subwoofers.

Titan™ 8 ACTIVE - REAR PANEL FEATURES

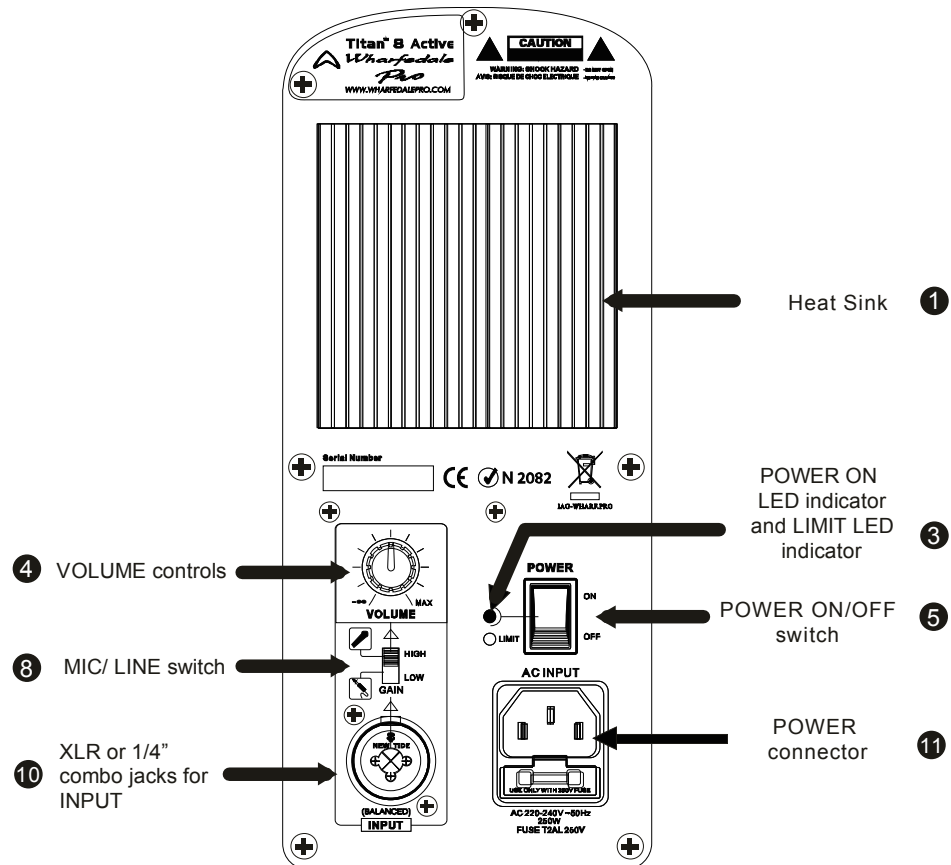

OPERATING MANUAL AND USER GUIDE

CONNECTION DIAGRAM # 2

USING TWO Titan™ Sub-A15's
WITH TWO POWERED SPEAKERS

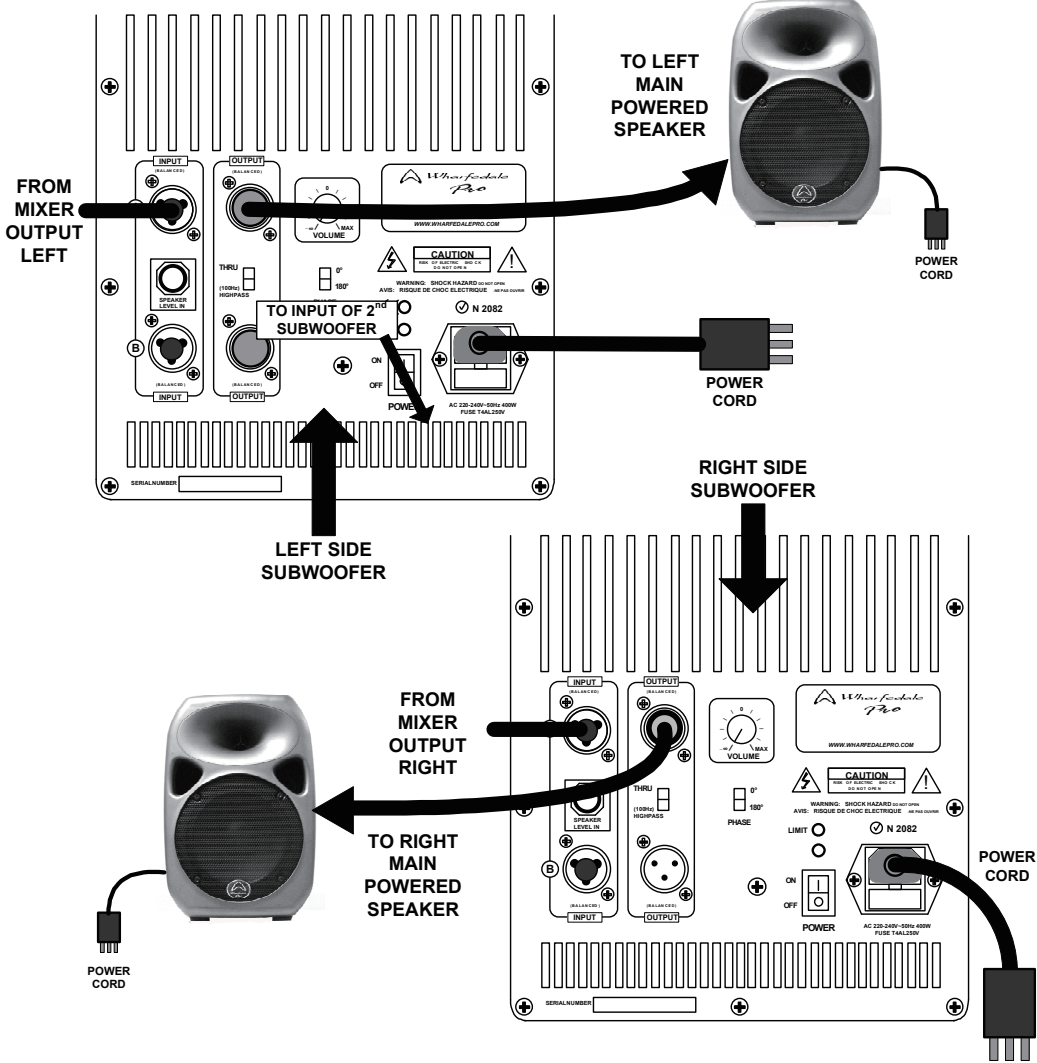

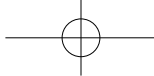

CONNECTION DIAGRAM # 3

Titan™ 8/12/15 MONO MAIN SYSTEM WITH TWO MONITORS
(another view)

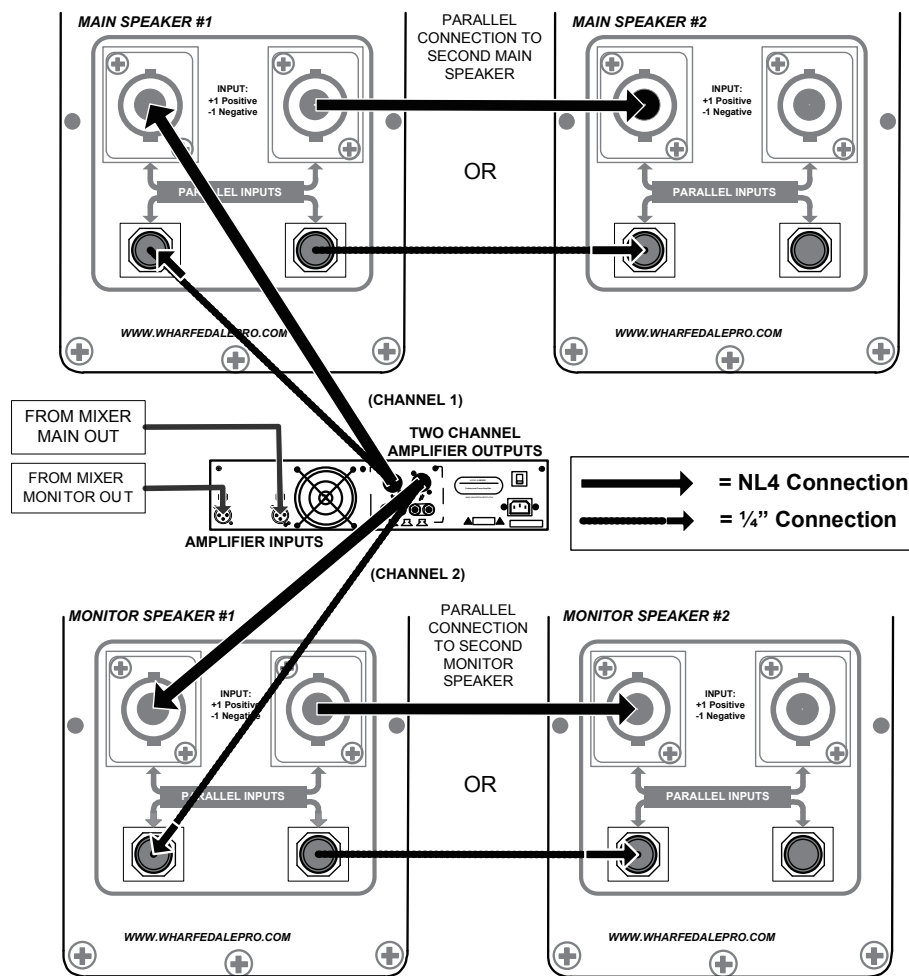

NOTE: This configuration represents a 4 ohm load to each output channel of the amplifier.

SPECIFICATIONS - Titan™ ACTIVE SERIES

| | Titan™ 8 ACTIVE | Titan™ 12 ACTIVE | Titan™ 15 ACTIVE |
|---------------------------------------|--------------------------------|--------------------------------|--------------------------------|
| System Type | Active 8" 2-way Bi-Amplified | Active 12" 2-way Bi-Amplified | Active 15" 2-way Bi-Amplified |
| Frequency Response (+/-3dB) | 70-20kHz | 55-20kHz | 50-20kHz |
| Low Frequency Driver (mm/in.) | 205mm / 8" | 305mm / 12" | 381mm / 15" |
| High Frequency Driver | Compression Driver | Titanium Compression Driver | Titanium Compression Driver |
| Exit Size (mm / inches) | 30mm / 1.2" | 25mm / 1" | 25mm / 1" |
| Dispersion (H x V) | 90° x 60° | 90° x 60° | 90° x 60° |
| Impedance (ohms) | 4Ω | 4Ω | 4Ω |
| Amplifiers | | | |
| Low Frequency (Class D) | Rated 150W RMS, 300W Peak | Rated 250W RMS, 500W Peak | Rated 350W RMS, 700W Peak |
| High Frequency (Class A/B) | Rated 30W RMS, 60W Peak | Rated 50W RMS, 100W Peak | Rated 70W RMS, 140W Peak |
| Electronic Crossover: | 24dB/octave Linkwitz-Riley | 24dB/octave Linkwitz-Riley | 24dB/octave Linkwitz-Riley |
| Crossover Frequency | 2.4kHz | 2.3kHz | 1.8kHz |
| Equalization: | | High (±10dB) 10kHz Shelving | High (±10dB) 10kHz Shelving |
| | | Low (±10dB) 100Hz Shelving | Low (±10dB) 100Hz Shelving |
| Bass Response Optimizer (BRO™) | | +5dB at 60Hz | +5dB at 60Hz |
| circuit | | | |
| Subsonic Filter | 30Hz, Second-order filter | 30Hz, Second-order filter | 30Hz, Second-order filter |
| Amplifier Protection | | | |
| Power On | Power switch on / off mute | Power switch on / off mute | Power switch on / off mute |
| Thermal | Amplifier shutdown, auto reset | Amplifier shutdown, auto reset | Amplifier shutdown, auto reset |
| Low Line Voltage Shut Down | 60% Nominal line voltage | 60% Nominal line voltage | 60% Nominal line voltage |
| Driver Protection | Independent LF and HF limiters | Independent LF and HF limiters | Independent LF and HF limiters |
| DC Protection | Yes | Yes | Yes |
| Short Protection | Yes | Yes | Yes |
| Clip Limiter: | Turns on approx 150W output | Turns on approx 250W output | Turns on approx 350W output |
| Limiter Indicator | Red LED | Red LED | Red LED |
| Power Indicator | Blue LED | Blue LED | Blue LED |



Titan™ REAR PANEL LAYOUT

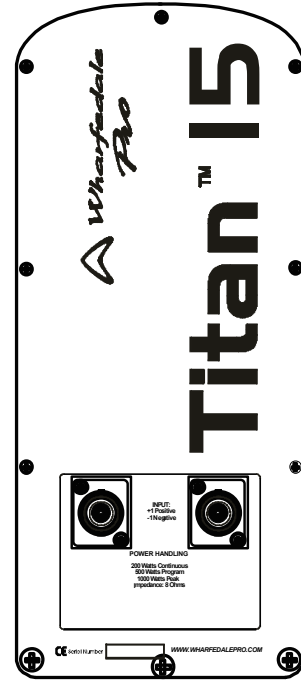
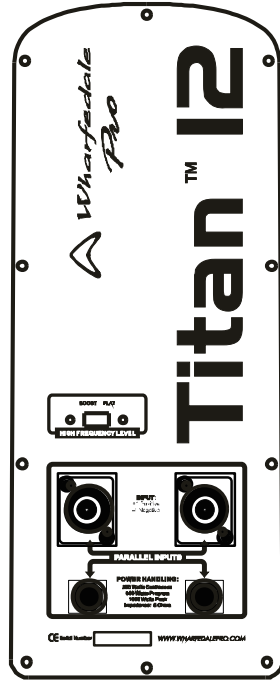
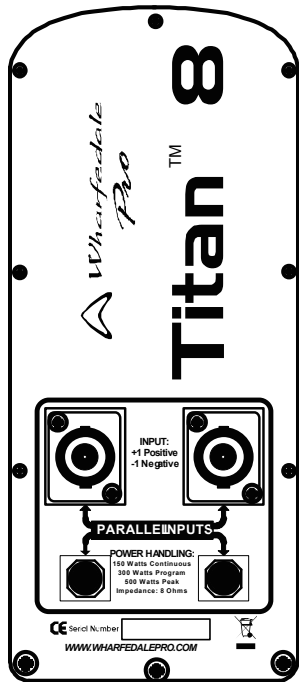

CONNECTION DIAGRAM #1

Titan™ 8/12/15 TWO - CHANNEL SOUND SYSTEM CONNECTION

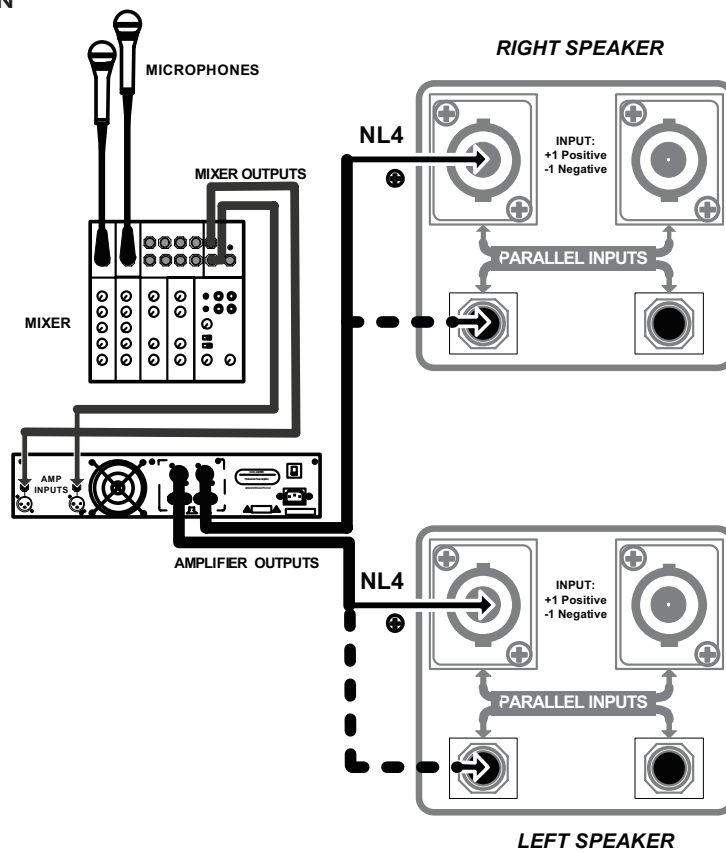

SPECIFICATIONS - Titan™ SUB SERIES

| | TITAN™ Sub-A15 | Titan™ Sub-A12 |
|---|---|---|
| System Type | Band-pass subwoofer | Reflex subwoofer |
| Frequency Response (+/-3dB) | 45-150Hz | 55-200Hz |
| Enclosure Material | 18mm Plywood | 15mm MDF |
| Enclosure Colour | Grey or Black | Grey or Black |
| Frame material | Die-cast aluminium frame | steel frame |
| Size (mm / inches) | 404mm / 15" | 305mm / 12" |
| Coil Size (mm / inches) | 75 / 3" | 64.26mm / 2.5" |
| Impedance | 4 ohm | 4 ohm |
| Speaker Pole Adapter | Yes | Yes |
| Inputs A & B - Type / Connection | Balanced Line Level inputs via two combo connectors | Balanced Line Level inputs via two combo connectors |
| Output A & B Type / Connection | Balanced Line Level inputs via two combo connectors | Balanced Line Level inputs via two combo connectors |
| Input Sensitivity | 0.775V | 0.37V |
| High Pass Frequency Selection | 100Hz | 150Hz |
| Phase Switch Selection | 0° / 180° | 0° / 180° |
| Crossover Frequency (HZ) | 150 | 80/ 100/ 120/ 150/ 180/ 200 (adjustable) |
| Speaker Level Input Impedance | 1/4" TS Phone input | |
| Speaker Level Input Connection | 4Ω | |
| Amplifier Power: Continuous | 400W | 250W |
| Amplifier Power: Peak | 600W | 500W |
| Power On Indicator | LED | LED |
| Power On Protection | Power switch on / off mute | Power switch on / off mute |
| Thermal Protection | Amplifier shutdown, auto reset | Amplifier shutdown, auto reset |
| Low Line Voltage Shut Down | 60% Nominal line voltage | 60% Nominal line voltage |
| Driver Protection | Independent LF limiters | Independent LF limiters |
| DC Protection | Yes | Yes |
| Short Protection | Yes | Yes |
| Clip Limiter: | Turns on approx 400W output | Turns on approx 250W output |
| Limiter Indicator | Red LED | Red LED |
| Power Indicator | Blue LED | Blue LED |
| Dimensions H x W x D: (mm) | 630.0 x 478.0 x 640.0 | 360.0 x 493 x 431.0 |
| Dimensions H x W x D (in) | 24.8 x 18.8 x 25.2 | 14.2 x 19.4 x 16.9 |
| Weight (Net) kg / lbs | 45.48kg / 100.0lbs | 22.31kg /49.0lbs |

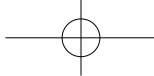

FEATURES

- ◆ 2-way reflex systems
- ◆ Passive (3) and Active (3) + Powered Subs (2)
- ◆ Low distortion, high power woofers
- ◆ 25.4mm Titanium high frequency compression drivers
- ◆ BRO™ Bass Response Optimizer (Titan™ 12/15 Active)
- ◆ Class D Low Frequency Amplifier (Active)
- ◆ Class A/B High Frequency Amplifier (Active)
- ◆ XLR output for connecting to another powered speaker
- ◆ RCA inputs for MP3, CD or other inputs
- ◆ Integral Elliptical Wave Guide (EWG) 90° x 60°
- ◆ Power On LED indicator in horn throat and back panel
- ◆ Active signal limiting system with LED indicator
- ◆ DTF™ Dynamic Thermal Filament HF driver protection (Titan™ 8,12,15 Passive)
- ◆ Light weight, high strength Polypropylene cabinet
- ◆ Integral 35mm (1-3/8") stand socket
- ◆ M6, M8 hanging points
- ◆ NL4 & 1/4" speaker inputs (Passive)
- ◆ Combo XLR/ 1/4" input jacks (Active)
- ◆ Internal crossover passive outputs (Sub-A12/15)
- ◆ Accommodates OmniMount® 60.0 bracket

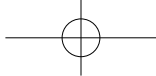

DIMENSIONS

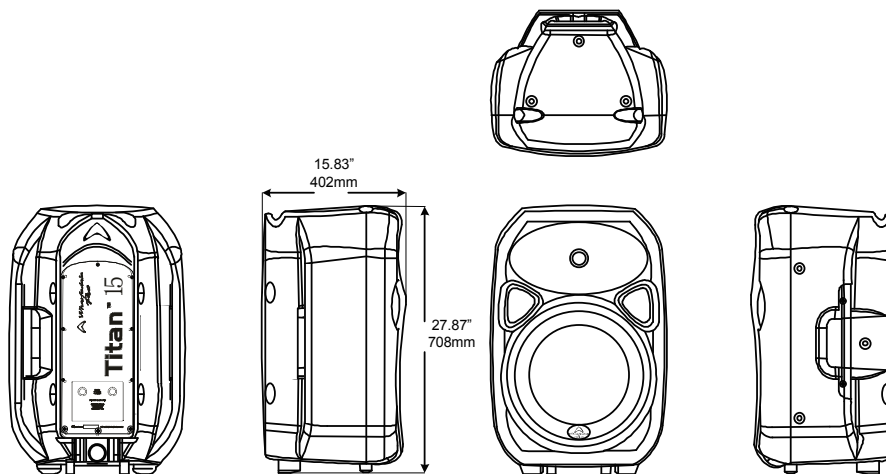

Titan™ 15

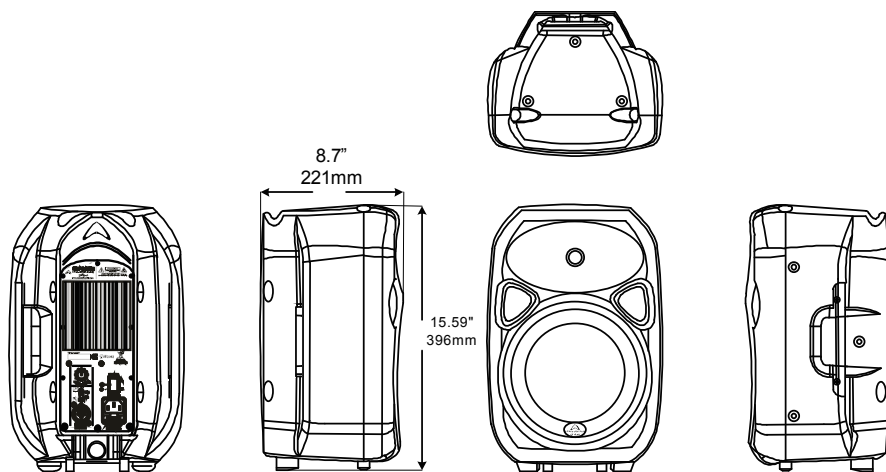
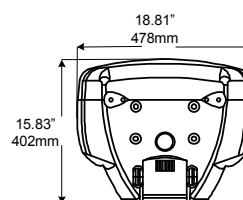

Titan™ 8A

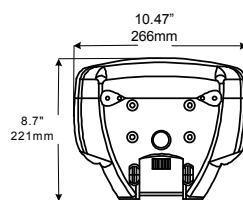

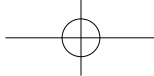

WHAT ABOUT THE Titan™ SERIES?

Wharfedale Pro Titan™ Series of passive and self-powered foreground/back-ground music and sound reinforcement speakers are designed for demanding professional applications such as reproduction and reinforcement of music and sound in venues as diverse as live performance venues, airports, houses of worship, A/V presentations, schools, retail shops, restaurants and public houses.

The Titan™ Series loudspeakers are high quality speaker systems designed to provide the best sound in a compact, feature laden, easy to use package. It is designed to provide transparent and accurate sound reproduction or reinforcement. The 25mm Exit Titanium high frequency drivers project crystal clear high frequencies. A proprietary 90° x 60° Elliptical Wave Guide (EWG) delivers the high frequencies in a well defined, even coverage pattern. Dynamic passages, such as the crack of a snare drum or the report of a cannon, come through just like the real thing.

The Titan™ Series are also ideal in Audio/Visual applications. The rich accurate sound is a great complement to any visual performance or presentation. Easy to transport and quick to set up, the Titan™ Active Series is the ideal choice for the serious professional.

Accessory wall brackets and rigging components available.

INTRODUCTION

Wharfedale Pro Titan™ Series loudspeakers are the result of many years of experience in the use, design and manufacturing of professional loudspeaker products. We take great pride in engineering and building every Wharfedale Pro loudspeaker and wish to thank you for entrusting us with your sound.

From the time Gilbert Briggs built his first loudspeaker in 1932, to the present, Wharfedale Loudspeakers have maintained the same standard of quality in components, workmanship and performance. Actually, Wharfedale is one of a few present day manufacturers that design, engineer and build all of their own transducers.

Please take a few minutes to read this manual completely in order to ensure that you get the most out of your Titan™ Series Loudspeaker system.

DIMENSIONS

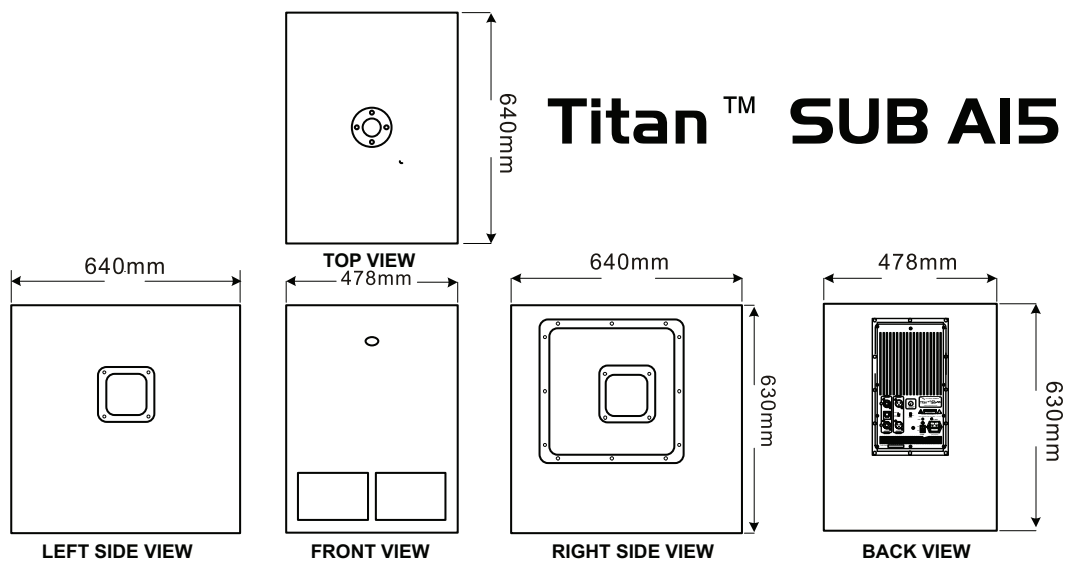
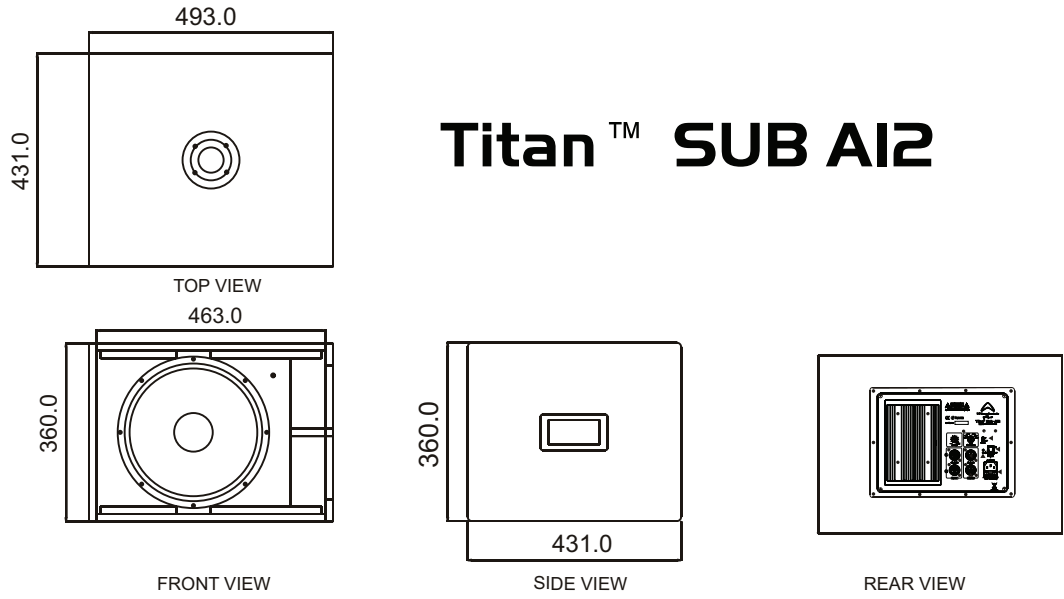

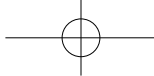

IMPORTANT SAFETY INFORMATION POWERED PRODUCTS

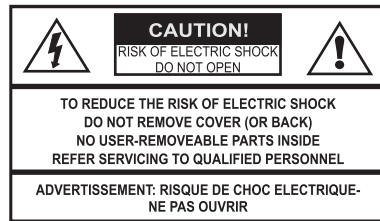

This symbol indicates that there are important operating and maintenance instructions in the literature accompanying this unit.



This symbol indicates that dangerous voltage constituting a risk of electric shock is present within this unit.

- Read these instructions.
- Keep these instructions.
- Head all warnings.
- Follow all instructions.
- Do not use this apparatus near water.
- Clean only with dry cloth.
- Do not block any ventilation openings.
- Install in accordance with the manufacturer's instructions.
- Do not install near any heat sources such as radiators, heat registers, Stoves, or other apparatus(including amplifiers) that produce heat.

Do not defeat the safety purpose of the polarized or grounding type plug. A polarized plug has two blades with one wider than the other. A grounding type plug has two blades and a third grounding prong. The wider blade or the third prong are provided for your safety. If the provided plug does not fit into your outlet, consult an electrician for replacement of the obsolete outlet.

Protect the power cord from being walked on or pinched, particularly at Plugs, convenience receptacles, and the point where they exit from the apparatus.

Use only attachments/accessories specified by the manufacturer.

Unplug this apparatus during lightning storms or when unused for long periods of time.

Refer all servicing to qualified service personnel.



Use only with a cart, stand, tripod, bracket, or table specified by the manufacturer, or sold with the apparatus. When a cart is used, use caution when moving the cart/apparatus combination avoid injury from tip-over.

Servicing is required when the apparatus has been damaged in any way, such as power supply cord or plug is damaged, liquid has been spilled or objects have fallen into the apparatus, the apparatus has been exposed to rain or moisture, does not operate normally, or has been exposed to rain or moisture, does not operate normally, or has been dropped.

Warning: To reduce the risk of fire or electrical shock, do not expose this product to rain or moisture. The product must not be exposed to dripping and splashing and no object filled with liquids such as a vase of flowers should be placed on the product.

No naked flame sources such as candles should be placed on the product.

Caution: Changes or modifications not expressly approved by the manufacturer could void the user's authority to operate this device.

Warning: The mains power switch for this appliance is located on the rear panel. To permit free access to this switch, the apparatus must be located in an open area without any obstructions.

ESSENTIAL INFORMATION FOR UK USERS

The power cord on your subwoofer may be supplied with a plug incorporating a fuse, the value of which is indicated on the pin face of the plug. Should the fuse need to be replaced, an ASTA or BSI approved BS1362 fuse must be used of the same rating. If the plug is cut off it must NOT be re-used. Dispose of any such plug safely. There is a danger of electric shock if a cut-off plug is inserted into a mains socket.

The wires in the mains lead are coloured in accordance with the following code: Green and Yellow - Earth: Blue - Neutral: Brown - Live.

As the colours of the wires in the mains lead may not correspond with the markings identifying the terminals in the replacement mains plug, proceed as follows:

The wire coloured Blue must be connected to the terminal marked with the letter "N" or coloured Black. The wire coloured Brown must be connected to the terminal marked with the letter "L" or coloured Red. The wire coloured Green and Yellow must be connected to the terminal marked with the letter "E" , or coloured Green, or Green and Yellow, or marked with the Earth symbol.

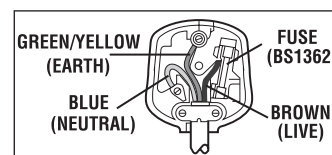

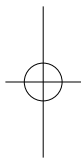
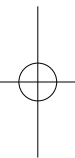
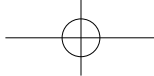

Wharfedale Professional
IAG HOUSE Sovereign Court, Ermine Business Park Huntingdon, Cambs, PE29 6XU, England

www.wharfedalepro.com

Wharfedale Professional reserves the right to alter or improve specifications without notice
All rights reserved © 2008 Wharfedale Pro. Wharfedale Pro is a member of the International Audio Group (IAG).

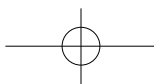

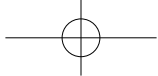

排版方式

| 封底 | 封面 |
|----|----|
| 30 | 1 |
| 28 | 3 |
| 26 | 5 |
| 24 | 7 |
| 22 | 9 |
| 20 | 11 |
| 18 | 13 |
| 16 | 15 |
| 14 | 17 |
| 12 | 19 |
| 10 | 21 |
| 8 | 23 |
| 6 | 25 |
| 4 | 27 |
| 2 | 29 |