

DN44BOB

DIGITAL MATRIXES

DANTE® Digital Audio Interface



USER MANUAL

INDEX

1. IMPORTANT REMARK	3
2. IMPORTANT SAFETY INSTRUCTIONS	3
3. IMPORTANT NOTE	5
4. INTRODUCTION	5
5. INSTALLATION	6
5.1. AC connection and powering on.....	6
5.2. Audio input connections	6
5.3. Audio output connections.....	7
5.4. Ethernet / DANTE® port for programming and control	7
5.5. GPI remote control ports.....	8
5.6. GPO remote control ports.....	8
6. FRONT PANEL LED INDICATORS	9
7. LOCATION, SET UP, VENTILATION.....	9
8. CLEANING.....	9
9. TECHNICAL CHARACTERISTICS	10

1. IMPORTANT REMARK



WARNING: SHOCK HAZARD - DO NOT OPEN
AVIS: RISQUE DE CHOC ÉLECTRIQUE - NE PAS OUVRIR



The lightning flash with arrowhead symbol, within an equilateral triangle, is intended to alert the user to the presence of uninsulated “dangerous voltage” within the product’s enclosure that may be of sufficient magnitude to constitute a risk of electric shock to persons.



The exclamation point within an equilateral triangle is intended to alert the user to the presence of important operating and maintenance (servicing) instructions in the literature accompanying the appliance.

WARNING (If applicable): The terminals marked with symbol of “” may be of sufficient magnitude to constitute a risk of electric shock. The external wiring connected to the terminals requires installation by an instructed person or the use of ready-made leads or cords.

WARNING: To prevent fire or shock hazard, do not expose this equipment to rain or moisture.

WARNING: An apparatus with Class I construction shall be connected to a mains socket-outlet with a protective earthing connection.

2. IMPORTANT SAFETY INSTRUCTIONS

1. Read these instructions.
2. Keep these instructions.
3. Heed all warnings.
4. Follow all instructions.
5. Do not use this apparatus near water.
6. Clean only with dry cloth.
7. Do not block any ventilation openings. Install in accordance with the manufacturer’s instructions.

8. Do not install near any heat sources such as radiators, heat registers, stoves, or other apparatus (including amplifiers) that produce heat.
9. Do not defeat the safety purpose of the polarized or grounding type plug. A polarized plug has two blades with one wider than the other. A grounding type plug has two blades and a third grounding prong. The wide blade or the third prong are provided for your safety. If the provided plug does not fit into your outlet, consult an electrician for replacement of the obsolete outlet.
10. Protect the power cord from being walked on or pinched particularly at the plugs, convenience receptacles, and at the point where they exit from the apparatus.
11. Only use attachments/accessories specified by the manufacturer.
12. Unplug the apparatus during lightening sorts or when unused for long periods of time.
13. Refer all servicing to qualified personnel. Servicing is required when the apparatus has been damaged in any way, such as power supply cord or plug is damaged, liquid has been spilled or objects have fallen into the apparatus, the apparatus has been exposed to rain or moisture, does not operate normally, or has been dropped.
14. Disconnecting from mains: Switching off the POWER switch all the functions and light indicators of the amplifier will be stopped, but fully disconnecting the device from mains is done unplugging the power cord from the mains input socket. For this reason, it always shall remain readily operable.
15. Equipment is connected to a socket-outlet with earthing connection by means of a power cord.
16. The marking information is located at the bottom of apparatus.
17. The apparatus shall not be exposed to dripping or splashing and that no objects filled with liquids, such as vases, shall be placed on apparatus.

NOTE: This equipment has been tested and found to comply with the limits for a Class A digital device, pursuant to part 15 of the FCC Rules. These limits are designed to provide reasonable protection against harmful interference when the equipment is operated in a commercial environment. This equipment generates, uses, and can radiate radio frequency energy and, if not installed and used in accordance with the instruction manual, may cause harmful interference to radio communications. Operation of this equipment in a residential area is likely to cause harmful interference in which case the user will be required to correct the interference at his own expense.



WARNING: This product must not be discarded, under any circumstance, as unsorted urban waste. Take to the nearest electrical and electronic waste treatment centre.

NEEC AUDIO BARCELONA, S.L. accepts no liability for any damage that may be caused to people, animal or objects due to failure to comply with the warnings above.

3. IMPORTANT NOTE

Thank you for choosing our Ecler **DN44BOB DANTE® Digital Audio Interface!**

It is **VERY IMPORTANT** to carefully read this manual and to fully understand its contents before any connection in order to maximize your use and get the best performance from this equipment.

To ensure optimal operation of this device, we strongly recommend that its maintenance be carried out by our authorised Technical Services.

Ecler **DN44BOB** comes with a **3-year warranty**.

4. INTRODUCTION

DN44BOB is a digital interface for Dante® audio over IP protocol. Its main features are:

- Ethernet interface.
- Digital audio transmission and reception in Dante® format.
- EclerNet compatibility.
- 4 balanced MIC/LINE inputs, phantom power and 3 levels of sensitivity, converted to Dante® format and sent to the network.
- 4 balanced line outputs, converted from 4 Dante® channels fed by the network
- Euroblock connectors for analogue audio inputs and outputs.
- 4 GPI ports (0-10VDC) on Euroblock connector.
- 4 GPO ports (NO/NC) on Euroblock connector.

To setup the DN44BOB, you have to use the EclerNet Manager* application. See the EclerNet Manager Application manual for more information.

* The EclerNet Manager application is available for download from www.ecler.com

To setup Dante® transmission and reception channels, the Audinate® Dante Controller application has to be used. See the EclerNet Manager Application manual for more information.

5. INSTALLATION

5.1. AC connection and powering on

The audio interface is powered by alternating current (AC) through its external power supply: 100-240 VAC, 50-60Hz.

The power supply must be correctly grounded (ground resistance, $R_g = 30\Omega$ or less). The operating environment should be dry and be totally free of dust. Do not expose the unit to dripping or splashing. Do not place incandescent objects like candles on top of it.



If the device requires any intervention and/or connection/disconnection, it must be powered off first. There are no user-serviceable parts within the unit.

To avoid buzzing, do not allow the power cable to intertwine with audio shielded cables.

5.2. Audio input connections

The DN44BOB rear panel provides 4 balanced analogue signal inputs labelled "IN" (7), supporting line or mic levels. The input signal type selection and handling is managed with EclerNet Manager Application. See the EclerNet Manager manual for more information.

Signal inputs use 3-position screw terminal blocks. The wiring is as follows:

Hot or direct signal > + terminal

Cold or inverted signal > – terminal

Ground > ⊥ terminal

For UNBALANCED connection, short circuit the terminal – to ground.

5.3. Audio output connections

The DN44BOB rear panel provides 4 balanced analogue line outputs labelled "OUT" (6).

Signal outputs use 3-position screw terminal blocks. The wiring is as follows:

Hot or direct signal	>	+ terminal
Cold or inverted signal	>	- terminal
Ground	>	⊥ terminal

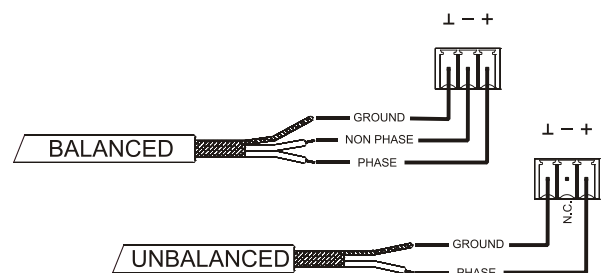

For unbalanced connection, don't connect the terminal -.

5.4. Ethernet / DANTE® port for programming and control

A RJ45 connector (11) allows to connect the device to an Ethernet network:

- Management from the EclerNet Manager application. See the EclerNet Manager application manual for more information.
- Direct connection (point-to-point) of a computer to a DN44BOB unit.
- Transmission and reception of 4 Dante® channels
- Connection to WPmSCREEN units (remote control of an entire network of EclerNet devices through custom UCP (User Control Panels), even from third-party devices, Android®, iOS®, etc.)

5.5. GPI remote control ports

The DN44BOB rear panel provides 4 GPI inputs (9) for 0-10VDC continuous voltage control. Each of these inputs can be connected to an external physical device (potentiometer, contact closure, variable 0-10V voltage, etc.) and assigned to a DN44BOB function, such as:

- Remote volume control of an input or output channel by external Ecler WpM series hardware like a WpMVOL potentiometer or a WpMVOL-IR remote control. For muting and unmuting, use a contact closure instead of potentiometer.
- Preset recall using a five-way selector, like a WpMVOL-SR

GPI connectors use 3-position screw terminal blocks. The wiring is as follows:

Positive, +10 VDC	>	+ terminal
Variable voltage, 0-10VDC	>	- terminal
Ground	>	⊥ terminal

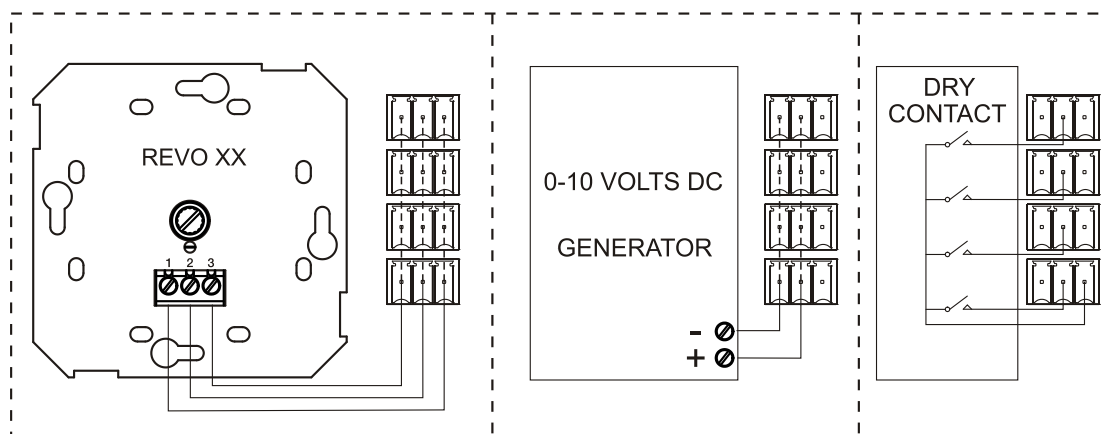

Connection examples

Connecting cables can be up to 500 meters long with a minimum section of 0,5 mm².

Please consult your ECLER dealer or www.ecler.com about the WpM series remote control wall panels.

5.6. GPO remote control ports

The DN44BOB rear panel provides 4 NO/NC (normally open/normally closed) relay outputs (8). The open or closed status of each relay can be saved in a DN44BOB preset. So loading a preset will restore the GPO status (open/closed) as it was when saved. It is then possible to interact with external equipment such as motorized projection screens or movable partitions, lights, sirens, GPI inputs of other equipment, etc.

6. FRONT PANEL LED INDICATORS

The DN44BOB front panel provides the following elements :

- POWER LED indicator (5): lights up when the unit is on.
- DANTE LED indicator (3):
 - Red LED: Ethernet network disconnected.
 - Green LED: Ethernet network connected and device operating as master (transmitting Dante® clock on the network).
 - Amber LED: Ethernet network connected and device operating as slave (synchronized with the clock of the Dante® Master unit on the network).
- DATA LED indicator (3): off when there is no connection with EclerNet Manager even if connected to Ethernet. Lit when connected to EclerNet Manager. Blinking to indicate data traffic with EclerNet Manager or other.
- Audio input (analogue) LED indicators (1): indicate the presence of an audio signal at the unit inputs and its intensity level (green, amber and red colours which correspond, in this order, to an increasing level of intensity).
- Audio output (analogue) LED indicators (2): indicate the presence of an audio signal at the unit outputs and its intensity level (green, amber and red colours which correspond, in this order, to an increasing level of intensity).

7. LOCATION, SET UP, VENTILATION

DN44BOB has been especially designed to be installed in a standard 19" rack, taking up 1U (height) and only half the width. It includes the PUM3 adapter, which allows two rack width media devices to be mounted on racks of 1 standard unit of measure (19").

The DN44BOB being a heat generator, it should not be enclosed or exposed to extreme temperatures.

If multiple amplifiers are installed in the same rack or in a cabinet with closed doors, it is highly recommended to install fans in their upper and lower ends for a forced air flow from the bottom up. This upward air flow will favour the dissipation of heat generated inside.

8. CLEANING

The casing should not be cleaned with solvents or abrasive materials since they can damage the screen printing. To clean the product, please used a cloth dampened with a mild liquid detergent and water, and wipe it off with a dry and clean cloth. Be careful that water never gets into the unit through its holes.

9. TECHNICAL CHARACTERISTICS

DSP	
DSP	32bit
Sampling Rate	44.1/ 48 / 88.2 / 96 kHz
Latency (fs = 48kHz)	1ms
AD/DA Converters	
Resolution	24bit AKM
Dynamic Range	AD:110dB; DA: 115dB
Latency (fs = 48kHz)	AD 0,81ms; DA: 0,56
Analog Input/Output	
4 Input/Output	Phoenix connector (Symmetrical)
Analog Input headroom	+27dBV = +30dBu
Max. output level	+18dBV = +21dBu
Input sensitivity @ 0dBV out	From -50dBV to +10dBV in 0.5dB step
Input Impedance	Balanced, >4k Ω
Phantom power	+18VDC, 5mA max. software switched
Frequency response (-3dB)	5Hz to 24kHz
Flatness	better than ± 0.1 dB
THD+Noise @ 1kHz, 0dBV input (line)	<0.004%
THD+Noise @ 1kHz, -40dBV input (mic.)	<0.008%
Output Noise floor FFT (20Hz - 20kHz)	better than 115dB
Interchannel crosstalk (20Hz - 20kHz)	better than 90dB (100dB typ.)
Channel Leakage (20Hz - 20kHz)	better than 100dB (115dB typ.)
CMRR 20Hz- 20kHz	65dB typ.
DANTE® Audio Interface	
DANTE® Network Inputs/Outputs	4 / 4
Latency	1 / 2 / 5ms (selectable)
Connector	1 x RJ45
Cable length between devices	100m CAT5 or CAT5e/CAT6

Processing	
Input Level (x4)	Range: from Off to 0 dB Mute: Yes Signal Polarity reverse: Yes Metering: VU+clip pre & post fader
Output Level (x4)	Range: from Off to 0 dB Mute: Yes Solo: Yes Signal Polarity reverse: Yes Metering: VU+clip pre & post fader
Output Gain (x4)	Range: from 0 to +6dB
Built in Signal Generator	Sine: from 20Hz to 20kHz Polarity: from 20Hz to 20kHz White noise Pink noise
Output Limiter (x8)	Bypass On-Off
Mechanical	
Dimensions (WxHxD)	241x44x152mm
Weight	1.1kg
Supply	
DC supply	24 VDC
Mains (Using supplied DC adapter)	100-240VAC 50-60Hz
Power consumption	6.5 W
Miscellaneous	
Management Connectivity	Ethernet Base-Tx 10/100Mb; Auto X-Over CAT5 up to 100m.
GPI	4, from 0 to 10VDC or TTL level
GPO	4, 3 poles isolated relay; 1A, 48 VDC max
Software	
EclerNet Manager	From v3.05r2 version
Operating System	Windows® 10; W8.1; W8; W7; Vista (SP1); XP Prof. (SP3); W2000 Prof. (SP4)
Minimum EclerNet System Requirements	Pentium IV @ 1GHz
	512MB RAM
	40MB HDD free space
	800x600 pixels & 16bits colour display
	10/100/1G Ethernet Network card

All product characteristics are subject to variation due to production tolerances. **NEEC AUDIO BARCELONA S.L.** reserves the right to make changes or improvements in the design or manufacturing that may affect these product specifications.

Motors, 166-168 08038 Barcelona - Spain - (+34) 932238403 | information@ecler.com | www.ecler.com