

M - 1

Welcome to Bowers & Wilkins and M-1

Thank you for choosing Bowers & Wilkins. When John Bowers first established our company he did so in the belief that imaginative design, innovative engineering and advanced technology were keys that could unlock the enjoyment of audio in the home. His belief is one that we continue to share and it inspires every product we design.



1 Contents

Check that you have:

1. Speaker on table stand
2. Wall bracket cover
3. Wall bracket

The wall bracket and cover are supplied clipped together. Pull them apart if required for installation.

If you peel off the rubber mat on the underside of the table stand, you will find a Torx key that you will need when making adjustments to the way the speaker is mounted.

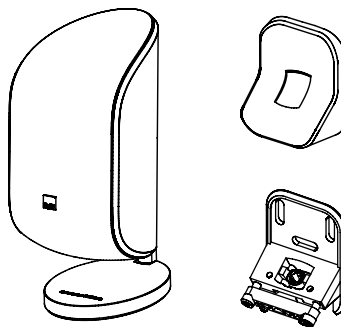

Figure 1

2 Positioning

The speakers may be used in distributed audio applications, where they are typically mounted more than 2.5m (8 ft) high on the wall pointing down. (see Sections 3 & 5)

For other applications, choose where you are going to place the speakers, using figures 2-6 according to the type of installation you want.

2.1 2- and 2.1-channel (stereo)

Figure 2 shows a range of angles to a central listener.

If the angle is less than 40°, you will not get sufficient left to right separation.

If the angle is greater than 60°, you may begin to detect a 'hole in the middle' effect, especially if listening away from the centre line. To reduce this effect, try toeing the speakers in to point towards a central listener. (See Section 6 on how to adjust the direction in which the speakers face.)

Either mount the speakers close to ear height or angle them to point to ear height at the centre of the listening area.

2-channel

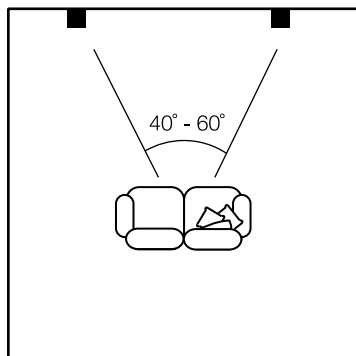

Figure 2

2.2 Multi-channel home theatre

Mount the front three speakers as shown in Figure 3. The height of the left and right speakers should be as close to the centre of the screen as possible. Their distance from the sides of the screen affects the scale of the acoustic image. 0.5m (20 in) is a good starting point, but experiment before fixing the speakers permanently in place.

The centre speaker should be near the bottom or top of the screen, whichever is closest to ear height.

Surround speakers are best placed at least 0.6m (2 ft) above head height, just like in a commercial cinema, to achieve a more diffuse effect

2.2.1 5.1-channel

For the two surround speakers, stick as close as possible to the angle specified in Figure 4. The proportions of the room will dictate whether the speakers should go on the side walls or the rear wall.

2.2.2 6.1-channel

In this case (Figure 5), two of the surround speakers should be placed in line with the centre of the listening area and the third directly behind.

2.2.3 7.1-channel

Figure 6 shows the optimum positions if you have four surround speakers.

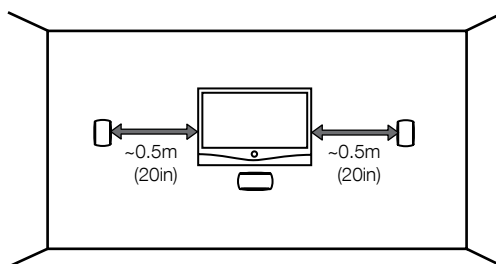

Figure 3

5.1-channel

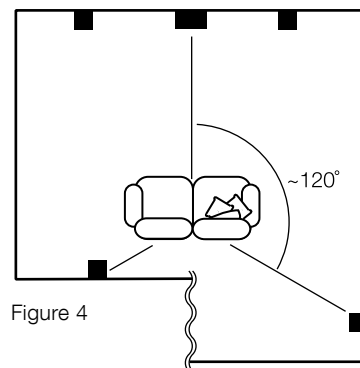

Figure 4

6.1-channel

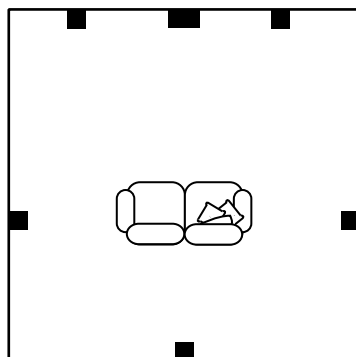

Figure 5

7.1-channel

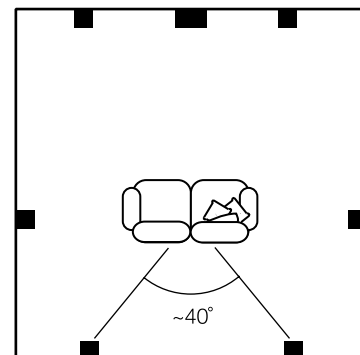

Figure 6

3 Moving the ball socket position

You can skip all of Section 3 completely if you are going to use the speaker in portrait orientation on its table stand as supplied, or you want to mount it high on the wall with maximum downward tilt (Figure 7).

Note: To achieve maximum tilt, it is necessary to invert the mounting of the wall bracket. (far right)



WARNING! This method of fixing is potentially less secure, because gravity will allow the product to fall if the stem is not properly fitted to the bracket. It is essential that the tapered ridge of the clamp bar engages the groove of the stem as shown in Section 5.

You are advised to avoid this method of fixing unless the degree of tilt is absolutely necessary. B&W Group cannot accept responsibility for any damage or injury arising as a result of using this method.

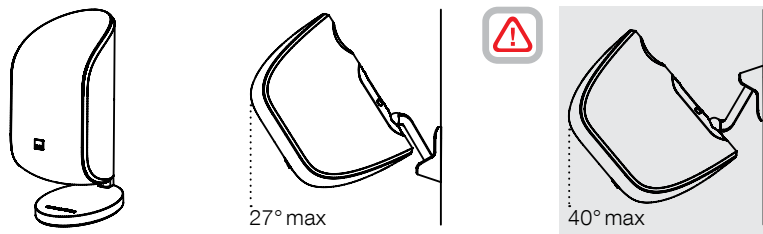

Figure 7

However, if you want to use it in landscape orientation – perhaps for centre channel use – or mount it on the wall in portrait orientation with the bracket hidden behind the speaker (Figure 8), you will need to change the position of the ball socket from the bottom to the centre of the speaker.

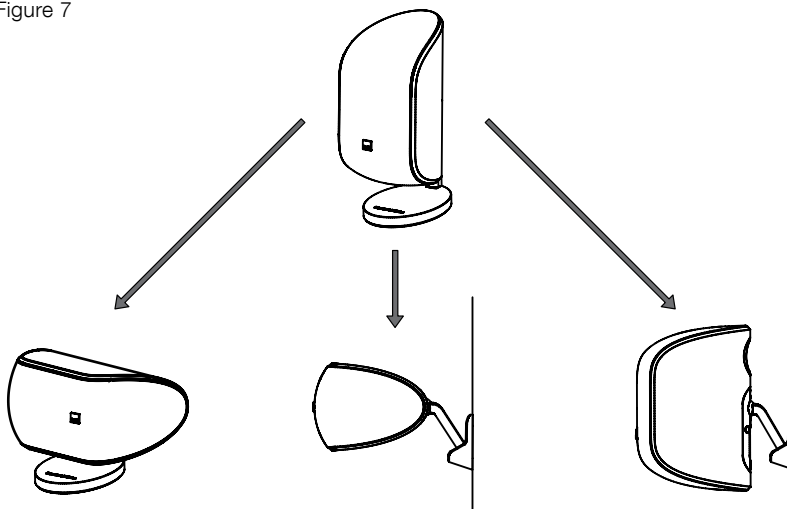

Figure 8

3.1 Removing the table stand base

Peel off the rubber mat from the underside of the base and remove the Torx key.

Locate the key in the cam-lock device and turn it anti-clockwise to unlock the stem (Figure 9).

Part the base from the speaker (Figure 10).

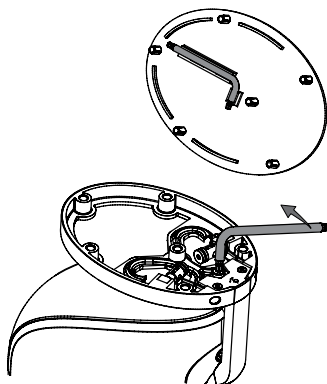

Figure 9

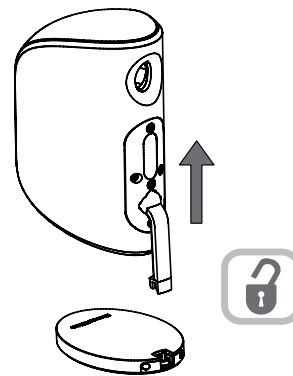

Figure 10

3.2 Removing and turning the back cover

Remove the three screws as shown in Figure 11 and pull the cover away from the back of the speaker.

Rotate the cover through 180° and re-assemble it to the back of the speaker, now with the ball joint positioned at the centre (Figure 12). Take care not to trap any wires.

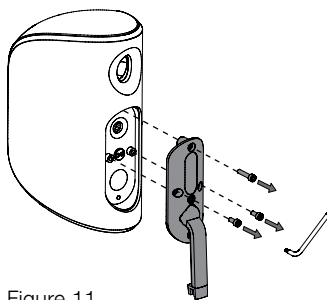

Figure 11

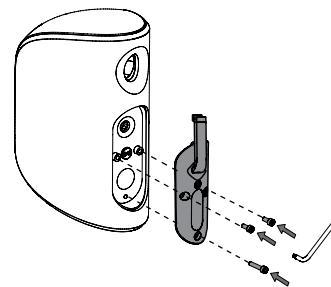

Figure 12

3.3 Rotating the stem

In all cases, loosen the accessible ball joint securing screw (A), rotate the stem through 90° and tighten the screw again. For landscape orientation, leave the stem in that position (Figure 13).

For wall-mount portrait orientation, where you do not need maximum downward tilt and want to hide the wall bracket as much as possible behind the speaker, loosen the other ball joint securing screw (B), rotate the stem a further 90° and tighten the screw (Figure 14).

Use the supplied Torx key.

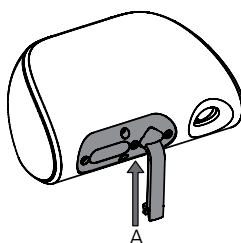

Figure 13

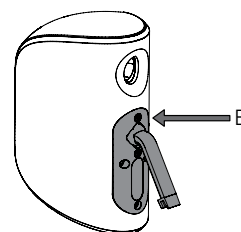

Figure 14

4 Connecting using the table stand

Remove the rubber mat from the underside of the base (Figure 15).

Strip back the outer sheath of the cable by 75mm (3 in) to expose the two inner sheathed wires.

Strip back the positive and negative wires to expose 10mm (3/8 in) of bare wire. If using multi-strand wire, twist the strands to obtain a neat end.

Feed each wire through the appropriate hole in the back of the base, observing the polarity coding as indicated. The wires will follow a channel and emerge in line with the side holes in the spring terminals.

Press the ends of the terminals fully and push the wire into the terminals. Then release the terminal ends to clamp the wire.

Replace the rubber mat.

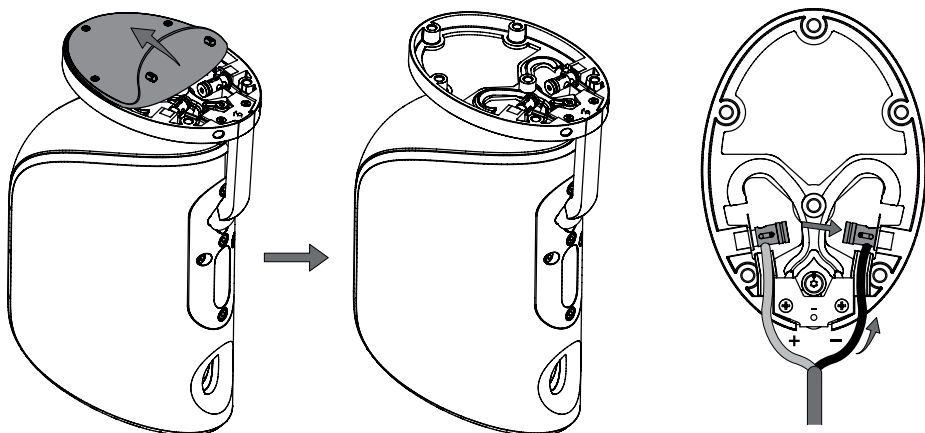

Figure 15

5 Fitting and connecting using the wall bracket

WARNING!

Do not attach the speaker to the ceiling. Decide how the cable is to be routed to the wall bracket – on the wall surface (from underneath only), chased into the plasterwork, or inside hollow (drywall) construction.

If routing the cable inside the wall or in the plaster layer, install it before fixing the wall bracket in place and leave 50mm (2 in) showing with the outer sheath stripped back.

Take care to route the cable clear of where the bracket fixing screws will be. For example, if the cable is chased into the plaster from above, omit the centre fixing screw.

If laying the cable on the wall surface, fit the wall bracket first. Cable cannot be routed around the support platform of the bracket when the cover is in place. There is only one knock-out in the cover as shown, so the cable must approach from this direction.

Using a spirit level, offer the wall bracket to the wall and mark out the fixing holes.

Drill and plug the wall as appropriate to the type of construction (screws and plugs not supplied).

If laying the cable on the wall surface from below, remove the knock-out at the bottom of the bracket cover to accommodate the cable.

Strip back the ends of the inner cores of the cable to expose 10mm (3/8 in) of bare wire and neatly twist if multi-strand. Connect the wires to the screw terminals, observing the correct polarity as shown.

Remove the table stand base, following the instructions in Section 3.1.

Slide the cover up the stem. Make sure the securing clamp is clear of the stem aperture in the bracket and push the end of the speaker stem fully into the aperture. Tighten the two screws through the securing clamp evenly using the Torx key supplied until the slack is taken out of the fit of the stem. Check that the tapered ridge of the clamp engages the groove in the stem. Do not over-tighten.

Slide the cover back down the stem and click into place on the wall bracket.

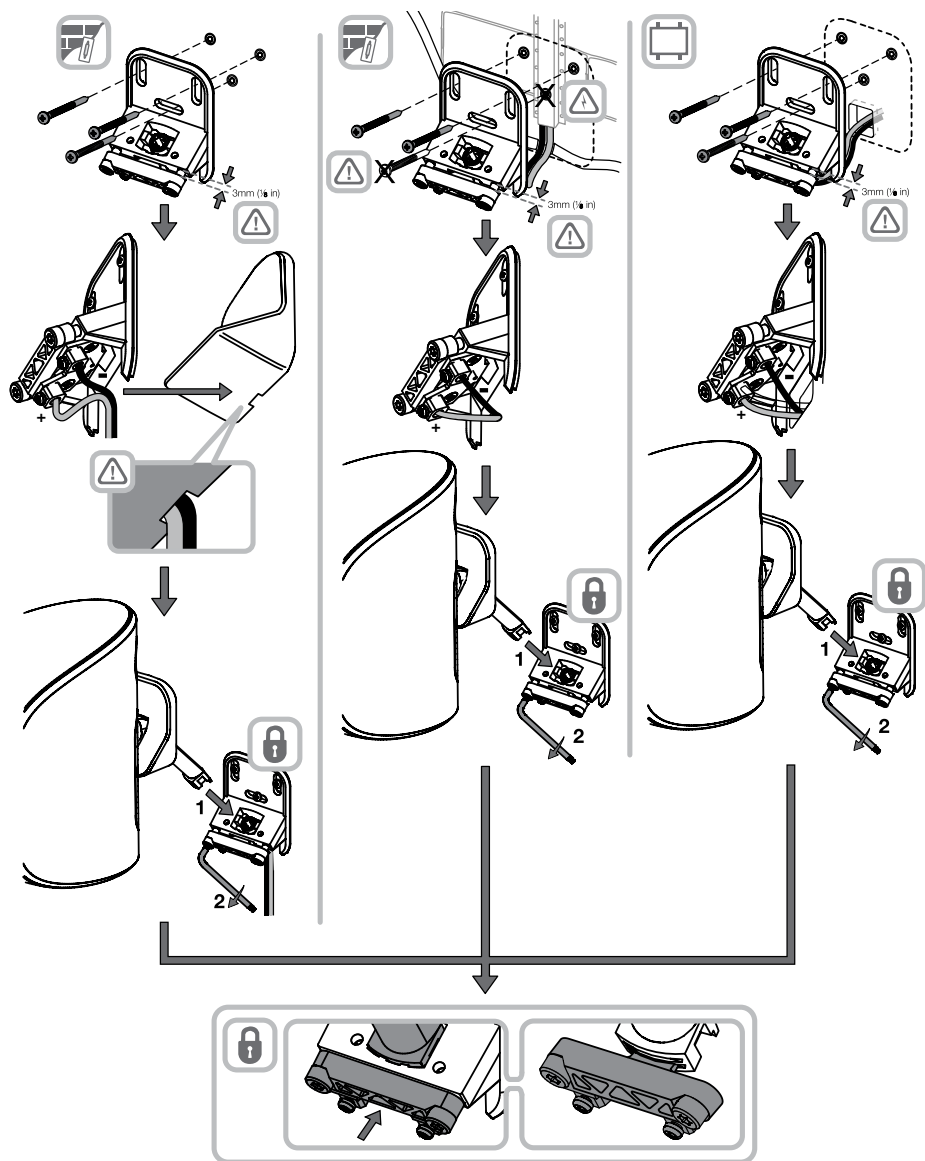

Figure 16

6 Adjusting the angle of the speaker

There are two screws next to the ball socket joint at the back of the speaker that tighten the joint to hold the speaker in place. It is only necessary to loosen one of these to free the joint. Indeed, in portrait orientation, only one screw will be accessible (Figure 17).

Use the supplied Torx key to loosen and tighten the screws.

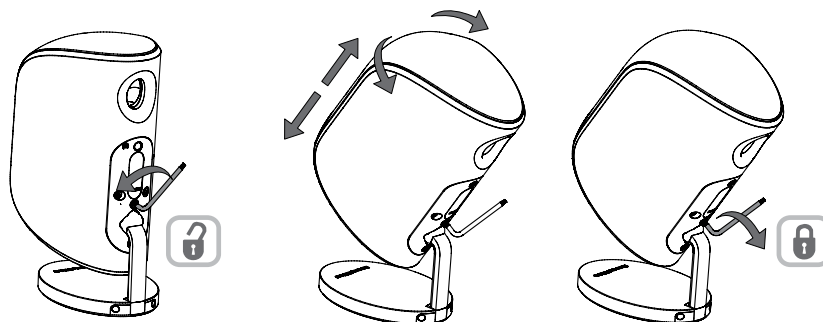

Figure 17

7 Rotating the badge

If using the speaker in landscape orientation, you will need to rotate the logo badge through 90°. The badge is spring loaded. Use the plastic film fitted to the rear of the badge to pull it out and rotate it. After doing so, remove the film (Figure 18).

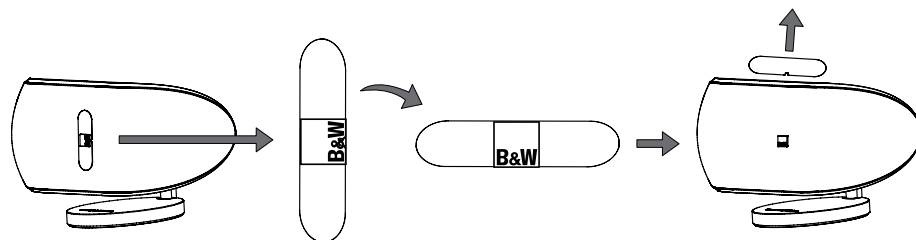

Figure 18

8 Environmental Information

This product complies with international directives, including but not limited to:

- i. the **R**estriction of **H**azardous **S**ubstances (RoHS) in electrical and electronic equipment,
- II. the **R**egistration, **E**valuation, **A**uthorisation and restriction of **C**hemicals (REACH)
- iii. the disposal of **W**aste **E**lectrical and **E**lectronic Equipment (WEEE).

Consult your local waste disposal authority for guidance on how properly to recycle or dispose of this product.