



User's Manual

DR active series



Antes de utilizar el equipo, lea la sección "Precauciones de seguridad" de este manual. Conserve este manual para futuras consultas.

Before operating the device, please read the "Safety precautions" section of this manual. Retain this manual for future reference.



Cajas acústicas activas / Self-powered loudspeaker enclosures

El signo de exclamación dentro de un triángulo indica la existencia de importantes instrucciones de operación y mantenimiento en la documentación que acompaña al producto. Conserve y lea todas estas instrucciones. Siga las advertencias.



The exclamation point inside an equilateral triangle is intended to alert the users to the presence of important operating and maintenance (servicing) instructions in the literature accompanying the product. Heed all warnings. Follow all instructions. Keep these instructions.

Equipo de Clase I.

Class I device.

El signo del rayo con la punta de flecha, alerta contra la presencia de voltajes peligrosos no aislados. Para reducir el riesgo de choque eléctrico, no retire la cubierta.



The lightning and arrowhead symbol warns about the presence of uninsulated dangerous voltage. To reduce the risk of electric shock, do not remove the cover.

La posición de encendido está indicada en el interruptor mediante los correspondientes símbolos normalizados (IEC 60417-1:1998 y IEC 60417-2:1998).

The ON position is indicated in the switch by means of the corresponding standardized symbols (IEC 60417-1:1998 and IEC 60417-2:1998).

No exponga este equipo a la lluvia o humedad. No use este aparato cerca del agua (piscinas y fuentes, por ejemplo). No exponga el equipo a salpicaduras ni coloque sobre él objetos que contengan líquidos, tales como vasos y botellas. Equipo IP-20.

Do not expose this device to rain or moisture. Do not use this apparatus near water (for example, swimming pools and fountains). Do not place any objects containing liquids, such as bottles or glasses, on the top of the unit. Do not splash liquids on the unit. IP-20 equipment.

Este símbolo indica que el presente producto no puede ser tratado como residuo doméstico normal, sino que debe entregarse en el correspondiente punto de recogida de equipos eléctricos y electrónicos.



This symbol on the product indicates that this product should not be treated as household waste. Instead it shall be handed over to the applicable collection point for the recycling of electrical and electronic equipment.

Equipo diseñado para funcionar entre 15°C y 35°C con una humedad relativa máxima del 75%, con un rango de ±10% de la tensión nominal de alimentación indicada en la etiqueta trasera (según IEC 60065:2001).

Working temperature ranges from 15°C to 35°C with a relative humidity of 75%, with ±10% of the rated main voltage value indicated on the rear label (according to IEC 60065:2001).

El cableado exterior conectado al equipo requiere de su instalación por una persona instruida o el uso de cables flexibles ya preparados.

The outer wiring connected to the device requires installation by an instructed person or the use of a flexible cable already prepared.

Si el aparato es conectado permanentemente, la instalación eléctrica del edificio debe incorporar un interruptor multipolar con separación de contacto de al menos 3mm en cada polo.

If the apparatus is connected permanently, the electrical system of the building must incorporate a multipolar switch with a separation of contact of at least 3mm in each pole.

Desconecte este aparato durante tormentas eléctricas, terremotos o cuando no se vaya a emplear durante largos periodos.

Unplug this apparatus during lightning storms, earthquakes or when unused for long periods of time.

No emplace altavoces en proximidad a equipos sensibles a campos magnéticos, tales como monitores de televisión o material magnético de almacenamiento de datos.



Do not place loudspeakers in proximity to devices sensitive to magnetic fields such as television monitors or data storage magnetic material.

Para las cajas con vaso para trípode, la altura máxima de seguridad desde el suelo a la base de la caja montada sobre trípode modelo TRD-2 con pies a su máxima extensión es:

For enclosures with tripod socket, maximum safety height from floor to bottom of enclosure when mounting on a TRD-2 tripod with legs fully open:

DR-108A ----->150 cm
DR-112A ----->140 cm
DR-15A, DR-115A ----->130 cm

DR-108A ----->150 cm
DR-112A ----->140 cm
DR-15A, DR-115A ----->130 cm

No existen partes ajustables por el usuario en el interior de este equipo. Cualquier operación de mantenimiento o reparación debe ser realizada por personal cualificado. Es necesario el servicio técnico cuando el equipo se haya dañado de alguna forma, como que haya caído líquido o algún objeto en el interior del aparato, haya sido expuesto a lluvia o humedad, no funcione correctamente, haya recibido un golpe o su cable de red esté dañado.

No user serviceable parts inside. Refer all servicing to qualified service personnel. Servicing is required when the apparatus has been damaged in any way, such as power-supply cord or plug is damaged, liquid has been spilled or objects have fallen into the apparatus, the apparatus has been exposed to rain or moisture, does not operate normally or has been dropped.

Limpie con un paño seco. No use limpiadores con disolventes.

Clean only with a dry cloth. Do not use any solvent based cleaners.

No instale el aparato cerca de ninguna fuente de calor como radiadores, estufas u otros aparatos que produzcan calor. Debe instalarse siempre sin bloquear la libre circulación de aire por las aletas del radiador.

Do not install near any heat sources such as radiators, heat registers, stoves or other apparatus that produce heat. The circulation of air through the heatsink must not be blocked.

GARANTÍA

Todos nuestros productos están garantizados por un periodo de 24 meses desde la fecha de compra.

Las garantías sólo serán válidas si son por un defecto de fabricación y en ningún caso por un uso incorrecto del producto.

Las reparaciones en garantía pueden ser realizadas, exclusivamente, por el fabricante o el servicio de asistencia técnica autorizado.

Otros cargos como portes y seguros, son a cargo del comprador en todos los casos.

Para solicitar reparación en garantía es imprescindible que el producto no haya sido previamente manipulado e incluir una fotocopia de la factura de compra.

WARRANTY

All D.A.S. products are warrantied against any manufacturing defect for a period of 2 years from date of purchase.

The warranty excludes damage from incorrect use of the product.

All warranty repairs must be exclusively undertaken by the factory or any of its authorised service centers.

To claim a warranty repair, do not open or intend to repair the product.

Return the damaged unit, at shippers risk and freight prepaid, to the nearest service center with a copy of the purchase invoice.



DECLARACIÓN DE CONFORMIDAD DECLARATION OF CONFORMITY

D.A.S. Audio, S.A.

C/ Islas Baleares, 24 - 46988 - Pol. Fuente del Jarro - Valencia. España (Spain).

Declara que la *serie DR active*:

Declares that *DR active series*:

Cumple con los objetivos esenciales de las Directivas:

Abide by essential objectives relating Directives:

- Directiva de Baja Tensión (Low Voltage Directive) 2006/95/CE
- Directiva de Compatibilidad Electromagnética (EMC) 2004/108/CE
- Directiva RoHS 2002/95/CE
- Directiva RAEE (WEEE) 2002/96/CE

Y es conforme a las siguientes Normas Armonizadas Europeas:

In accordance with Harmonized European Norms:

- EN 60065:2002 Audio, video and similar electronic apparatus. Safety requirements.
- EN 55103-1:1996 Electromagnetic compatibility. Product family standard for audio, video, audio-visual and entertainment lighting control apparatus for professional use. Part 1:Emission.
- EN 55103-2:1996 Electromagnetic compatibility. Product family standard for audio, video, audio-visual and entertainment lighting control apparatus for professional use. Part 2:Immunity.

CONTENTS

INTRODUCTION	3
General information	
Features	
AMPLIFIER DESCRIPTION	4
Models: <i>DR-15A</i> and <i>DR-108A</i>	
Models: <i>DR-112A</i> and <i>DR-115A</i>	
CONNECTIONS	6
Signal wiring	
Full range connection	
Reinforcement with powered subwoofer	
Passive subwoofer reinforcement	
Loop thru	
INSTALLATION	7
Placement	
Tripod use	
Stage monitor use	
Mounting to walls and ceilings. Hanging	
USE	8
Switch ON/OFF	
Limiter indicators (Limit)	
Equalisation	
Overheating	
Low mains voltage	
TROUBLESHOOTING	9
BLOCK DIAGRAMS	10
LINE DRAWINGS	11
SPECIFICATIONS	11
APPENDIX	12

Line connections: unbalanced and balanced

INTRODUCTION

General information

Thank you for purchasing **D.A.S. Audio S.A.** products. The *DR series* represents more than 30 years of expertise in transducer and enclosure design, achieving a system that utilises the most advanced sound reinforcement technology to deliver outstanding audio performance and maximum reliability.

This manual contains the required information to make the best use of the system you have purchased. Please take the time to read it.

Our Web site at **www.dasaudio.com** contains further support information such as enclosure and system drawings, data for modelling software, architectural specifications and specification sheets.

General features

DR-15A / DR-15AW

- 15" woofer.
- High frequency compression driver with 1.34" coil.
- Medium power.
- Medium sensitivity.
- Medium throw.
- Hanging points (M8): 2 upper, 2 lower and 4 rear.
- Optional mounting accessory.
- Optional "W" version.

DR-108A

- 8" woofer.
- High frequency compression driver with 1" coil.
- Medium / low power.
- Medium sensitivity.
- Medium throw.
- Hanging points (M8): 3 lower.
- Optional mounting accessory.

DR-112A

- 12" woofer.
- High frequency compression driver with 1.34" coil.
- Medium power.
- Medium sensitivity.
- Medium throw.
- Hanging points (M8): 3 upper and 2 lower.
- Optional mounting accessory.

DR-115A

- 15" woofer.
- High frequency compression driver with 1.34" coil.
- Medium power.
- Medium sensitivity.
- Medium throw.
- Hanging points (M8): 3 upper and 2 lower.
- Optional mounting accessory.

Amplifier features

(Models: DR-15ADR-15AW and DR-108A)

- DMAT (Discrete Monolithic Amplifier Technology) 150W amplifier for the low frequencies and 50W for the high frequencies.
- Active limiter system.
- Linkwitz-Riley crossovers for greater vocal clarity.
- Plug & play self-powered systems.
- Power, signal presence and overload indicator lights (LEDs) let you know what is going on.
- Built-in 2-channel mixer with line and microphone inputs allows all-in-one operation for the most compact applications.
- Balanced line output for daisy-chaining as many units as needed.

Amplifier features

(Models: DR-112A and DR-115A)

- State of the Art amplifier technology including class-D high efficiency low weight amplifiers.
- Plug & play self-powered systems.
- XLR (Cannon) balanced input.
- XLR (Cannon) parallel output.
- Line and microphone use.
- 300W amplifier for lower frequencies and 100W for upper frequencies.

AMPLIFIER DESCRIPTION

DR-15A and DR-108A amplifier

A) LINE :

Controls the level for the LINE input.

B) MIC:

Controls the level for the MIC (microphone) input.

C) LEVEL:

Controls the system's main level, acting on the microphone and line mix.

D) LINE OUT :

This 1/4" (6.35 mm) line output is used to send the built-in mixer output signal. As many units as required can be daisy-chained. It can also be used to feed a power amplifier. It is located before the main LEVEL control, and thus this control can be used as the level control for each system within a group of daisy-chained systems. This balanced connector has three pins for which pin assignments are as follows :

Sleeve = GND (Ground).

Tip = (+) non-inverted signal.

Ring = (-) inverted signal.

E) LINE INPUT :

1/4" (6.35 mm) and XLR (Cannon) combo line input. Plug in line sources such as mixers, keyboards, CD players, audiocassette or video players. This input has two sets of three pins for which pin assignments are as follows:

1 or Sleeve=GND (Masa).

2 or Tip=(+) non-inverted signal.

3 or Ring=(-) inverted signal.

F) MIC :

Microphone input via an XLR (Cannon) connector. Plug in any microphone that does not require phantom powering. This input has three pins for which pin assignments are as follows :

1 = GND (Ground).

2 = (+) non-inverted signal.

3 = (-) inverted signal.

G) SIGNAL :

Signal presence indicator led. Shows signal presence at the mixer output but before the main LEVEL control. Thus, it is dependent on the position of the microphone (MIC) and LINE controls.

H) OVERLOAD :

Clip indicator red led. Amplifier saturation (clip) indicator.

I) MIC GAIN:

Controls the input gain for the microphone input to accommodate different microphone sensitivities. Factory set to mid position.

J) AC INPUT :

Standard IEC male connector, fuse holder and power switch. Plug the unit mains cable here. Replace fuse on the fuse holder with a same type fuse, if the fuse is blown.

Power switch (with standard symbols):

Turns the unit on = 'I'

Turns the unit off = 'O'

K) Power-on indicator red led (at the front of the box).

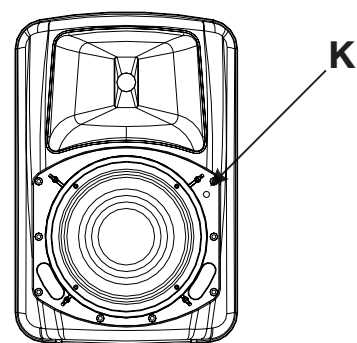
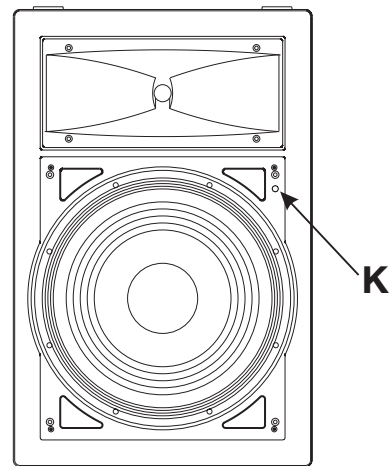
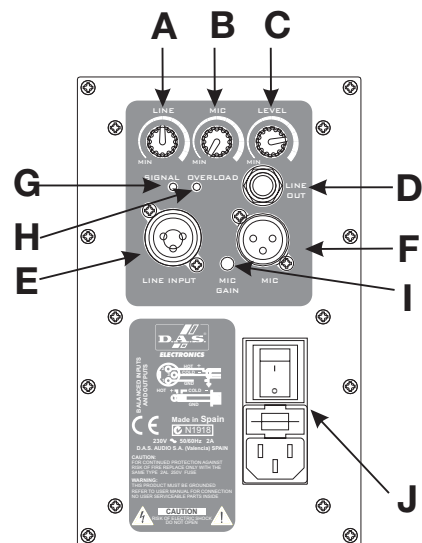

DR-112A and DR-115A amplifier

A) MIC/LINE :

Switches between microphone and line modes. The indicator light on the left hand side of the switch is lit when the microphone mode is activated.

B) LOW CUT:

Switches a 100 Hz high-pass filter on and off.

C) LEVEL:

Controls the level of the system.

D) LOOP THRU :

Used for paralleling several units, which will share the same input. This balanced connector has three pins for which pin assignments are as follows :

- 1 = GND (Ground).
- 2 = (+) non-inverted signal.
- 3 = (-) inverted signal.

E) LINE INPUT :

Balanced signal XLR. Pin assignments as follows :

- 1 = GND (Ground).
- 2 = (+) Non-inverted signal.
- 3 = (-) Inverted signal.

F) ON :

Power-on indicator green led.

G) SIGNAL :

Signal presence indicator green led.

H) LIMIT :

Limiter indicator leds for each of the frequency bands, LF and HF.

I) AC INPUT :

Standard IEC male connector, fuse holder and power switch. Plug the unit mains cable here. Replace fuse on the fuse holder with a same type fuse, if the fuse is blown.

Power switch (with standard symbols):

- Turns the unit on = 'I'
- Turns the unit off = 'O'

J) Power-on indicator red led (at the front of the box).

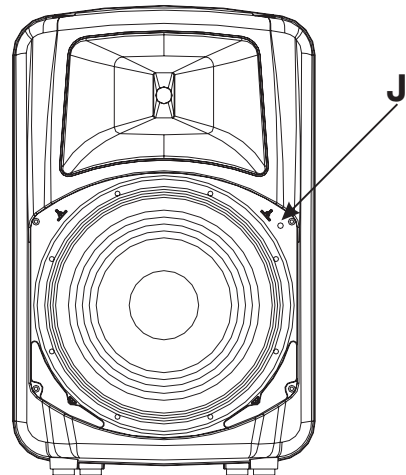
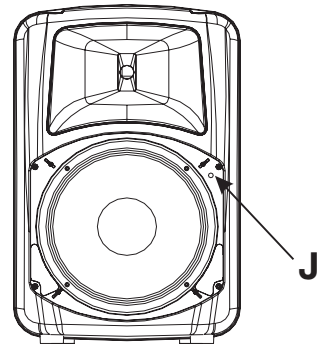
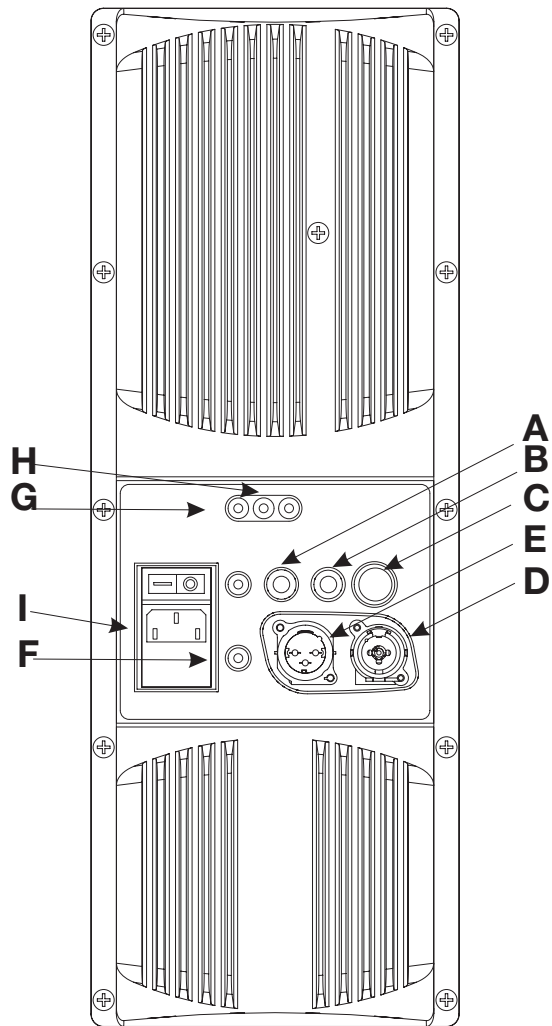

CONNECTIONS

Signal wiring

There are two basic ways to transport an audio signal with microphone or line level:

Unbalanced line: Utilising a two-conductor cable, it transports the signal as the voltage between them. Electro-magnetic interference can get added to the signal as undesired noise. Connectors that carry un-balanced signals have two pins, such as RCA (Phono) and 1/4" (6.35 mm, often referred to as jack) mono. 3-pin connector such as XLR (Cannon) may also carry un-balanced signals if one of the pins is unused.

Balanced line: Utilising a three-conductor cable, one of them acts as a shield against electro-magnetic noise and is the ground conductor. The other two have the same voltage with respect to the ground conductor but with opposite signs. The noise that cannot be rejected by the shield affects both signal conductors in the same way. At the device's input the two signals get summed with opposite sign, so that noise is cancelled out while the programme signal doubles in level. Most professional audio devices use balanced inputs and outputs. Connectors that can carry balanced signal have three pins, such as XLR (Cannon) and 1/4" (6.35 mm) stereo.

We recommend the use of balanced wiring with the *DR active series*. The illustrations on Appendix of this manual show the recommended connection with different types of connectors to balanced processor or amplifier inputs.

The system can be used as a full range system, or with subwoofer reinforcement:

Stand alone full-range use connection

Simply plug the mixer output into the enclosure's input. If you have more than one box per channel, use the LOOP THRU output to link the signal from one box to the next as shown.

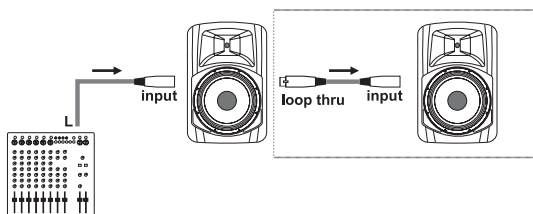

Powered sub-woofer reinforcement connection

To use it in combination with a self-powered subwoofer (such as the *sub-18HA*), plug the mixer into the subwoofer, and connect the satellite output to the *DR-112A/115A*. If you have more boxes per channel, simply daisy chain *DR-112A/115A*s and subwoofers as shown.

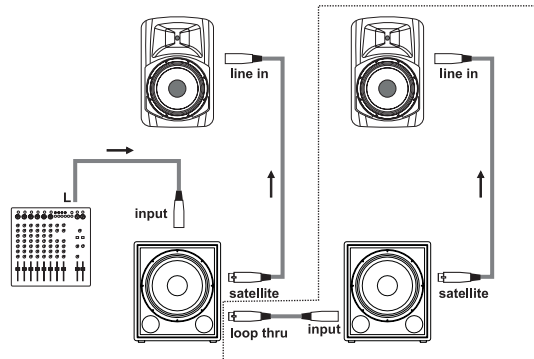

Passive sub-woofer reinforcement connection

The system can be complemented by a passive subwoofer unit such as the *sub-18HF*. You will need a power amplifier and a two-way stereo electronic crossover unit, such as a *DSP-26*, crossing over at a frequency in the 100-160 Hz range. The graph shows an example of a connection using a passive (non-powered) subwoofer.

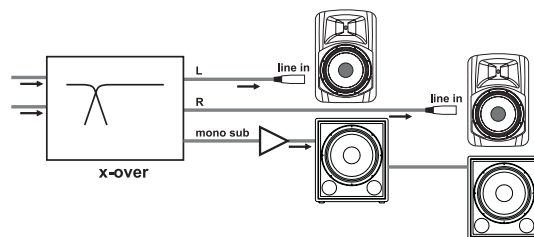

Loop thru

The LOOP THRU output is an output XLR in parallel with the input connector and is useful for daisy chaining the input signal to a number of boxes, connecting them in parallel.

The number of units that can be linked this way depends on the output impedance of the equipment driving the enclosure, such as the mixer or processor. Typically, to avoid signal degradation, the maximum number that can be daisy chained is given by the formula $(1250/Z)$, where Z is the output impedance of the equipment driving the enclosure. For instance, a 100 ohm output impedance allows daisy chaining 12 boxes.

INSTALLATION

Placement

Place the speakers ahead of the microphones. Feedback (howling) occurs when the microphones pick up the sound that comes out of the speakers and feeds it back to the system. Feedback can cause damage to your unit. If space is limited, direct the speakers towards areas where there are no microphones to minimise feedback.

When using a turntable, place the speakers far from the turntables. If the speaker signal is picked up by the stylus and re-amplified, low frequency howling will occur. The use of a very heavy base for the turntable is recommended.

Note: The angle on the back of models *DR-112A* and *DR-115A* allows for floor monitor use without extra accessories. The illustrations show box operation angles.

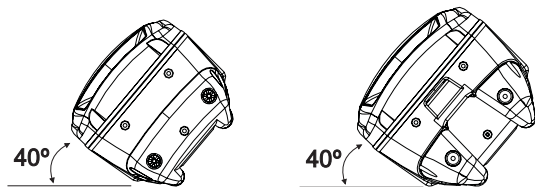

Tripod use

The unit is equipped with a built-in tripod socket for use with standard 35-mm tripods such as the *TRD-2*. The socket has a locking screw to fix the orientation of the box; make sure it is unscrewed enough before mounting the box onto the tripod, so that the screw is not in the way of the tripod and does not protrude from the tripod socket. Be careful not to raise the box too high on the tripod, as it may become unstable.

Place the speakers as high as possible. For best results, try to place the high frequency unit above the audience's heads. If the loudspeakers are located too low, the listeners at the end of the room will not hear quality sound.

Mounting to walls and ceilings. Hanging

Optional wall and/or ceiling mounting brackets are available for all full-range models. These are detailed on the "Specifications" section.

Hanging hardware should be regularly inspected and suspect units replaced if in doubt. This is important to avoid injury and absolutely no risks should be taken on this respect. The units can only be flown individually, but up to three *DR-112A/115A*s can be flown vertically from one another.

The *ANL-1* set is a set of four eyebolts and four carabiners for flying that is available separately. The following illustration shows the detail of the *ANL-1*'s components.

Use on top of *sub-18H/ sub-18HF*

The model *sub-18H/sub-18HF* is equipped with a built-in upper 35 mm socket (this is the standard tripod diameter). Then, with the *TRD-4* accessory (optional), one *DR active* unit can be used on top of one *sub-18H/sub-18HF* unit.

Do not use mounted systems on irregular floors or with slopes.

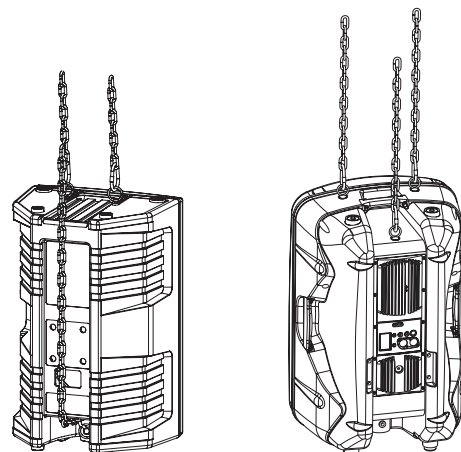
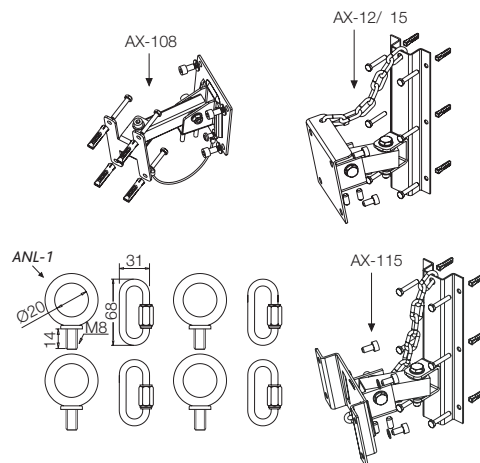
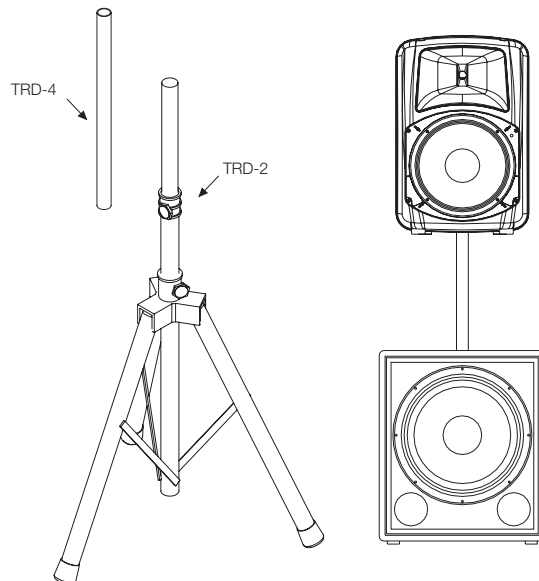

USE

Switch ON/OFF

A sound system should be switched on sequentially. Switch on the self-powered unit last in your sound system. Switch on the sound sources such as CD players or turntables, then the mixer and finally the self-powered unit. If you have several units, it is recommended that you switch them on sequentially one at a time.

Follow the inverse order when switching off, turning self-powered units off before any other element in the sound system.

Mute all signal sources before switching the unit on or off.

Limiters indicators (LIMIT)

It is recommended that the red LIMIT LED indicators are not lit continuously; at most they should blink only occasionally.

If you wish to have a visual indication at the mix position of whether the LIMIT LEDs are lighting, during equipment set-up, closely observe what mixer VUmeter level corresponds to the level that lights the enclosure's LIMIT LEDs. That level should not be exceeded during the event.

Equalisation

The units do not need extreme settings of equalisation to produce quality sound. Avoid high levels of gain on the equalisers. Gain values above +6 dB on a console's EQ are not recommended.

For speech applications the LOW CUT is recommended to filter out low frequency excess. It can also be useful if we need to drive the boxes at very high levels, relieving some of the excursion off the cone.

Overheating

Due to their high efficiency, the *DR series* amplifiers generate very little residual heat and therefore do not need a fan for cooling. In normal use, the amplifier panel will be warm to the touch.

If the unit stops playing (or just the mid-high or the bass sections), the amplifier's overheating protection may be activated to protect the components from thermal damage.

Overheating may be due to insufficient cooling, or to very aggressive use in extremely hot conditions. Do not use the unit in proximity to high power lights.

Once the amplifier cools down, it switches back on automatically. If the unit should shut down again, try reducing the volume a notch to avoid overheating.

Low mains voltage

If mains voltage falls below the shutdown voltage for the unit, it will stop playing. When acceptable levels are regained, the unit will switch back on automatically.

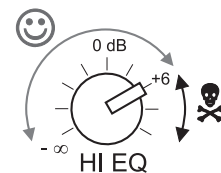
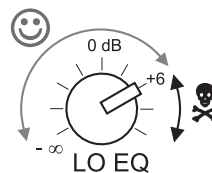

AC = 230 V

Current consumption (A)	DR-15A & DR-108A	DR-112A & DR-115A
Max. Power	1,1	2,9
1/3 Power	0,5	0,66
1/8 Power	0,25	0,2
Idle	0,1	0,1

Heat emission (BTU/h)	DR-15A & DR-108A	DR-112A & DR-115A
Max. Power	860	2270
1/3 Power	390	515
1/8 Power	195	155
Idle	80	80

TROUBLESHOOTING

PROBLEM	CAUSE	SOLUTION
No sound from the unit. The power on LED indicator (on the front of the unit) does not light up when the power switch is at the on ("I") position.	<ol style="list-style-type: none"> 1 - Bad or loose AC connection to the unit or the mains outlet. 2 - Faulty AC cable. 3 - Blown Fuse. 	<ol style="list-style-type: none"> 1 - Check you connections. Insert the IEC plug securely into the unit's AC socket. 2 - Check the cables, connectors and AC power with a suitable mains tester. 3 - Replace fuse on fuse holder under AC input with a same fuse type only. If it blows again, take the unit to a service centre.
No sound from the unit. The power on LED indicator (on the front of the unit) lights up when the power switch is at the on ("I") position.	<ol style="list-style-type: none"> 1 - The channel (MIC or LINE) or the main (LEVEL) volume controls are set too low. 2 - The signal source is sending no signal. 3 - Defective cable. 	<ol style="list-style-type: none"> 1 - Turn up the volume for the channel you are using (MIC or LINE) as well as the main LEVEL control. 2 - Check that the mixer or sound source is sending signal to the unit. 3 - Check that the cable from the sound source to the unit is connected correctly. Replace the cable if defective.
Full power cannot be obtained. The OVERLOAD or LIMIT indicators never lights up.	<ol style="list-style-type: none"> 1 - The channel (MIC or LINE) or the main (LEVEL) volume controls are not at maximum. 2 - The signal source does not have a hot enough output. 	<ol style="list-style-type: none"> 1 - Turn the channel (MIC or LINE) or the main (LEVEL) volume controls up. 2 - If using a mixer, use the balanced output if available. Use a professional mixer with a hotter output, or use a preamplifier between the sound source and the unit.
Feedback appears when the LEVEL is turned up.	<ol style="list-style-type: none"> 1 - The microphone is pointing towards the speakers. 2 - The microphone is not directional enough or the talker/performer is too far from the microphone. 3 - Incorrect EQ. 	<ol style="list-style-type: none"> 1 - Place the speakers in front of the microphones. 2 - Use quality directional microphones such as cardioid, super-cardioid or hyper-cardioid and/or nicely ask the talker/performer to talk. 3 - Avoid high gain settings on the equaliser.
Sound is distorted, but LIMIT or OVERLOAD indicators do not light up.	<ol style="list-style-type: none"> 1 - The mixer is distorting. 2 - The signal reaching the unit is too hot. 	<ol style="list-style-type: none"> 1 - Turn the down the main out or the channel gains on the mixer. Check the signal source. 2 - Set the LEVEL control no lower than ten o'clock. Lower the main mixer output level.
Sound is distorted and very loud. The OVERLOAD (or LIMIT) LED indicator lights up.	<ol style="list-style-type: none"> 1 - The system is overloaded and has reached maximum power. 	<ol style="list-style-type: none"> 1 - Turn the mixer level down. 2 - Turn the channel (MIC or LINE) or the main (LEVEL) volume controls down. 3 - If the LIMIT LED lights up, press the LOW CUT button.
The microphone can hardly be heard with the LEVEL control at maximum.	<ol style="list-style-type: none"> 1 - The unit is not being used in microphone mode. 	<ol style="list-style-type: none"> 1 - Set the LEVEL control to 9 o'clock approximately and press the MIC/LINE button. Adjust the LEVEL control further to get the desired level. 2 - Adjust the MIC GAIN control further to get the desired level.
When speaking into a microphone, voices are heavy.	<ol style="list-style-type: none"> 1 - Microphone proximity effects. Bass gets dramatically louder when speaking too close to the microphone. 	<ol style="list-style-type: none"> 1 - Speak a little further away from the microphone. Press the LOW CUT button and /or turn down the low frequency equalisation if available.

PROBLEM	CAUSE	SOLUTION
Hum or buzz when a mixer is connected to the unit.	<p>1 - The console probably has unbalanced outputs. You may be using an incorrect un-balanced to balanced cable.</p> <p>2 - The mixer and powered speaker are not plugged into the same mains outlet.</p> <p>3 - The audio signal cable is too long or too close to an AC cable.</p>	<p>1 - Read the Appendix A of this manual to make a correct un-balanced to balanced cable.</p> <p>2 - Connect the mixer and the powered speaker to the same mains outlet.</p> <p>3 - Use a cable that is as short as possible and/or move the audio signal cable away from mains cables.</p>
Hum or buzz when a CD, cassette, VCR or keyboard is connected to the unit.	<p>1 - The equipment and powered speaker are not plugged into the same mains outlet.</p> <p>2 - The audio signal cable is too long or too close to an AC cable.</p> <p>3 - The mains cable has only two conductors and therefore has not a ground terminal and the chassis is not grounded adequately.</p> <p>4 - The cable is defective and has an open shield.</p>	<p>1 - To determine if the hum is coming from the equipment connected to the powered speaker set the main LEVEL control to minimum and check if the hum goes away. If that is the case, connect the mixer and the powered speaker to the same mains outlet.</p> <p>2 - Use a cable that is as short as possible and/or move the audio signal cable away from mains cables.</p> <p>3 - Replace the mains cord with one that has a ground conductor.</p> <p>4 - Replace the cable.</p>
Hum or buzz when using lighting controls in the same building.	<p>1 - The audio signal cable is too long or too close to the lighting cable.</p> <p>2 - On a sound system with three-phase AC, the lighting equipment and the unit are connected to the same phase.</p>	<p>1 - Move the audio signal cable away from lighting cables. Try to find out at what point the noise is leaking into the system.</p> <p>2 - Connect the sound system to a different phase than the lights. You may need the help of an electrician.</p>

BLOCK DIAGRAMS

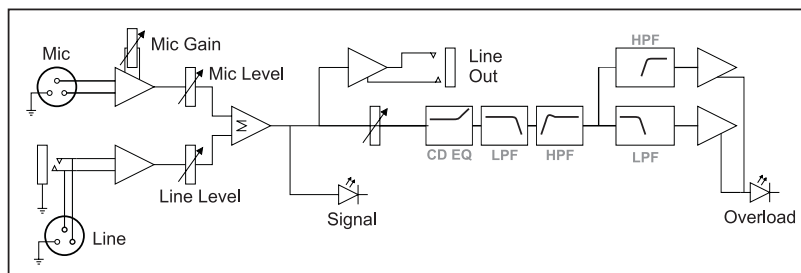

DR-108A and DR-15A amplifier

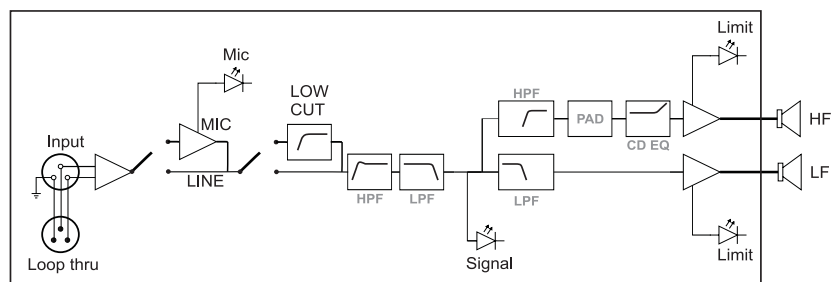

DR-112A and DR-115A amplifier

LINE DRAWINGS

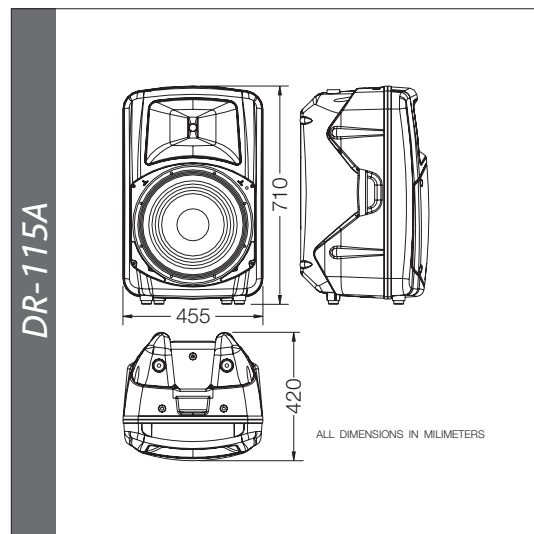
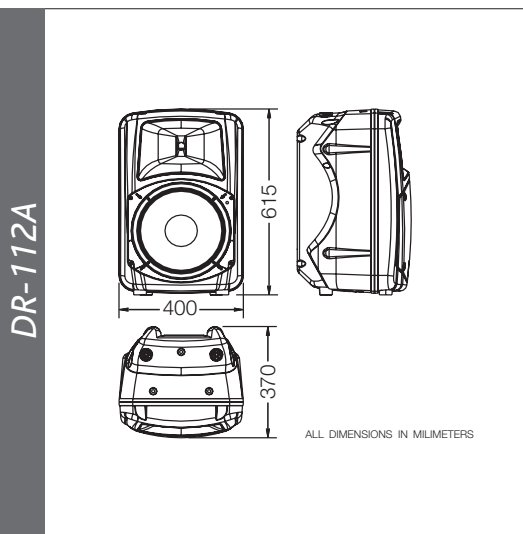
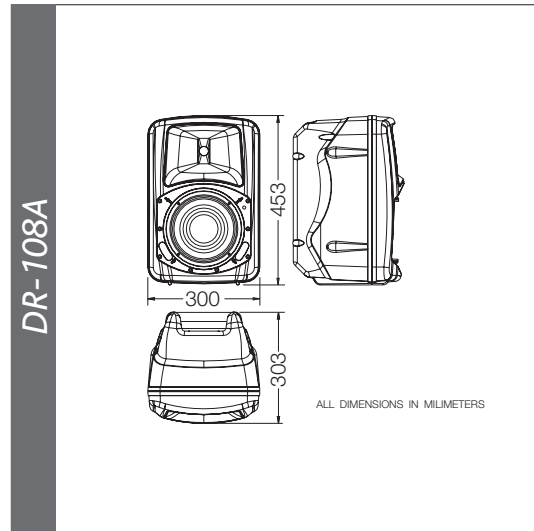
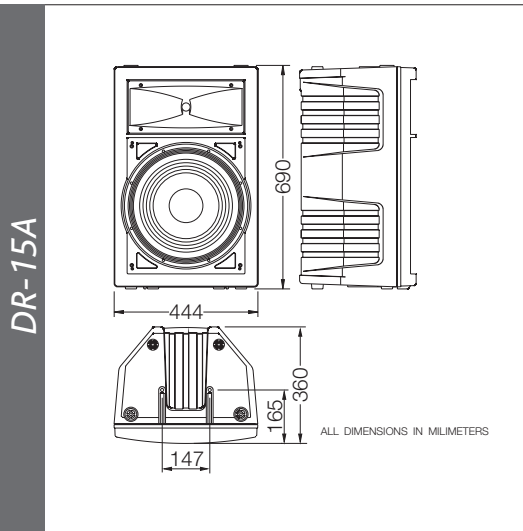

SPECIFICATIONS

MODEL	DR-15A/DR-15AW	DR-108A	DR-112A	DR-115A
Nominal LF Power Amplifier	150 W (AB)	150 W (AB)	300 W (D)	300 W (D)
Nominal HF Power Amplifier	50 W (AB)	50 W (AB)	100 W (AB)	100 W (AB)
Input Type	Balanced Differential Line	Balanced Differential Line	Balanced Differential Line	Balanced Differential Line
Input Impedance	Line: 20 kohms; Mic: 2 kohms	Line: 20 kohms; Mic: 2 kohms	Line: 20 kohms	Line: 20 kohms
Sensitivity	Line: 0.75 V (-0.28 dBu) Mic: 3mV, 150mV (-48dBu, -14dBu)	Line: 0.75 V (-0.28 dBu) Mic: 3mV, 150mV (-48dBu, -14dBu)	Line: 1.23 V (+4 dBu)	Line: 1.23 V (+4 dBu)
Frequency Range(-10 dB)	45 Hz-20 kHz	60 Hz-18 kHz	50 Hz-20 kHz	45 Hz-20 kHz
Rated Maximum Peak SPL at 1 m ⁽¹⁾	127 dB	120 dB	128 dB	130 dB
HF Horn Coverage Angles (-6 dB)	90° H x 70° V	90° H x 45° V	90° H x 45° V	90° H x 45° V
Enclosure Material	Polypropylene	Polypropylene	Polypropylene	Polypropylene
Finish/Color	Black or White (W)	Black	Black	Black
Transducers/Replacement Parts	LF: 15Mi/GM 15Mi HF: M-34/GM M-34	LF: 8B/8B HF: M-26/GM M-26	LF: 12Mi4/GM 12Mi4 HF: M-34/GM M-34	LF: 15Mi4/GM 15Mi4 HF: M-34/GM M-34
Connectors INPUT	Female XLR-Jack	Female XLR-Jack	Female XLR	Female XLR
LOOP THRU	Jack	Jack	Male XLR	Male XLR
MIC	XLR	XLR		
AC INPUT	Male IEC	Male IEC	Male IEC	Male IEC
Dimensions(H x W x D)	70 x 45 x 36 cm 28 x 18 x 15 in	45 x 30 x 30 cm 18 x 12 x 12 in	62 x 40 x 37 cm 24 x 16 x 14.5 in	71 x 46 x 42 cm 28 x 18 x 16.5 in
Weight	23.4 kg (51.5lb)	12.2 kg (26.8lb)	19.7 kg (43.5lb)	22.1 kg (48.5lb)
Accessories	ANL-2 FUN-15 TRD-2	ANL-1 AX-M FUN-DS-108 TRD-2	ANL-1 AX-115 TRD-2 FUN-DS-112	ANL-1 AX-115 FUN-DS-115 TRD-2

Notes: (1), Maximum calculated Peak SPL based on sensitivity and RMS amplifier power.

APPENDIX: Line connections: unbalanced and balanced

There are two basic ways to transport an audio signal with microphone or line level:

Unbalanced line: Utilising a two conductor cable, it transports the signal as the voltage between them. Electromagnetic interference can get added to the signal as undesired noise. Connectors that carry unbalanced signals have two pins, such as RCA (Phono) and ¼" (6.35mm, often referred to as jack) mono. 3 pin connector such as XLR (Cannon) may also carry unbalanced signals if one of the pins is unused.

Balanced line: Utilising a three conductor cable, one of them acts as a shield against electromagnetic noise and is the ground conductor. The other two have the same voltage with respect to the ground conductor but with opposite signs. The noise that cannot be rejected by the shield affects both signal conductors in the same way. At the device's input the two signals get summed with opposite sign, so that noise is cancelled out while the programme signal doubles in level. Most professional audio devices use balanced inputs and outputs. Connectors that can carry balanced signal have three pins, such as XLR (Cannon) and ¼" (6.35mm) stereo.

The graphs that follow show the recommended connection with different types of connectors to balanced processor or amplifier inputs. The connectors on the left-hand side come from a signal source, and the ones on the right hand side go to the inputs of the processor or amplifier. Note that on the unbalanced connectors on the left-hand side, two terminals are joined in side the connector. If hum occurs with balanced to balanced connections, try disconnecting the sleeve (ground) on the input connector. Note that the illustrations show what should be connected to what, but that pin locations on an actual XLR connector are different. Also, pin 2 hot is assumed on XLR connectors.

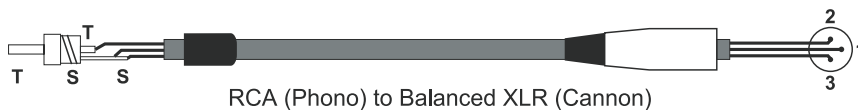
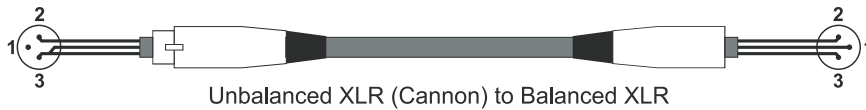
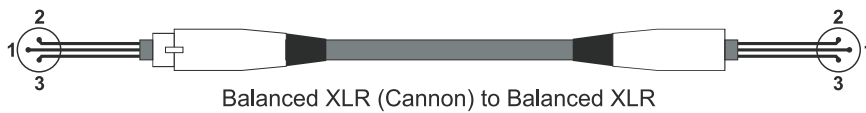

EN

www.dasaudio.com



D.A.S. AUDIO, S.A.

C/. Islas Baleares, 24
46988 Fuente del Jarro
Valencia, SPAIN
Tel. 96 134 0525
Tel. Intl. +34 96 134 0860
Fax 96 134 0607
Fax Intl. +34 96 134 0607

D.A.S. AUDIO OF AMERICA, INC.

Sunset Palmetto Park
6816 NW 77th Court.
Miami, FL. 33166 - U.S.A.
TOLL FREE: 1-888DAS4USA
Tel. +1 305 436 0521
Fax +1 305 436 0528

D.A.S. AUDIO ASIA PTE. LTD.

25 Kaki Bukit Crescent #01-00/02-00
Kaki Bukit Techpark 1
Singapore 416256
Tel. +65 6742 0151
Fax +65 6742 0157