

INSTRUCTION MANUAL

SONANCE CINEMA® SERIES IN - WALL SPEAKERS



Introduction

Thank you for purchasing Sonance Cinema® Series in-wall speakers. When properly installed, these speakers will deliver film soundtracks and music with outstanding clarity and realism, even in the largest home theater rooms. This manual covers the Sonance Cinema Series LCR1, LCR2, SUR1 and SUR2 models.

Box Contents

Each Sonance Cinema Series speaker box contains the following:

- (1) Cinema Series LCR or SUR speaker
- (1) Paintable grille
- (1) Allen wrench
- (1) Mounting cutout template

Speaker Placement

NOTE: CINEMA SPEAKERS CAN BE ORIENTED EITHER VERTICALLY OR HORIZONTALLY WITH NEARLY IDENTICAL PERFORMANCE. WHEN ORIENTING THE CINEMA SUR1 AND SUR2 HORIZONTALLY, ROTATE THE MIDRANGE/TWEETER PANEL 90° (SEE STEP 5, ON PAGE 2).

Left, Center & Right Channels

- Place the left & right speakers on either side of the video screen, anywhere from 6 feet to 10 feet apart and 38 – 42 inches from the floor. The speakers should be at least 18 inches away from the side walls.
- If possible, locate the center speaker at the same height as the left & right channel speakers (38 – 42 inches from the floor).
- If you must place the center speaker above or below a video screen, place it no more than 2 feet above or below the center of the left and right speakers. This will maintain consistent tonality between all 3 front channel speakers.
- The main listening position should be between 8 and 12 feet away from the speakers.

Use *Figure 1* as a guide.

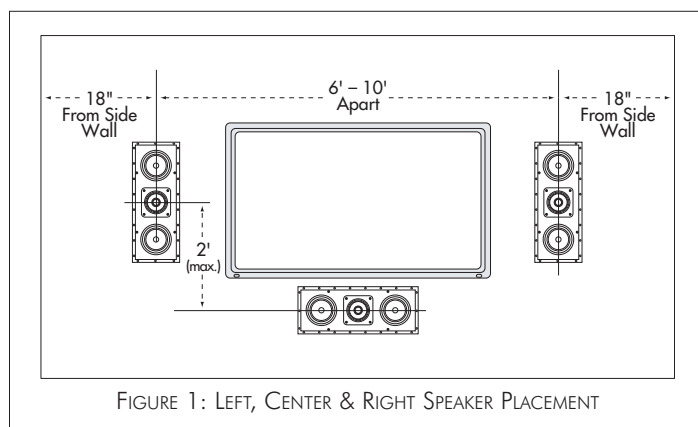

FIGURE 1: LEFT, CENTER & RIGHT SPEAKER PLACEMENT

Left & Right Surround Speakers

Place the left & right surround speakers directly to the sides of the listening position, between 5 and 7 feet off the floor.

Use *Figure 2* as a guide.

Surround Back Channel Speakers

The surround back speakers in a 6.1- or 7.1-channel system should be placed on the rear wall between 4 feet and 8 feet apart, at least 5 feet from the floor. Use *Figure 3* as a guide.

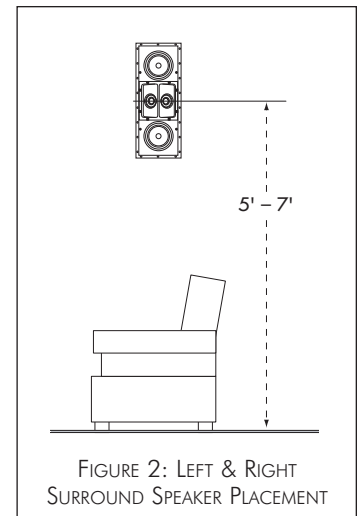

FIGURE 2: LEFT & RIGHT SURROUND SPEAKER PLACEMENT

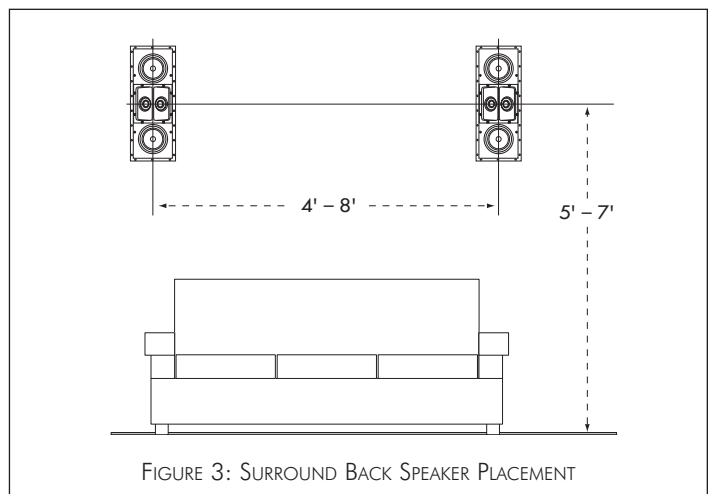

FIGURE 3: SURROUND BACK SPEAKER PLACEMENT

Before Installation

- Determine the location for the speaker (see *Speaker Placement*).
- Perform an obstruction survey to be certain that there are no studs, conduit, pipes, heating ducts, pocket doors or air returns in the wall cavity that will interfere with the speaker.
- The cutout for Cinema LCR1 and SUR1 speakers is 7½" x 20½" (191mm x 521mm). The cutout for Cinema LCR2 and SUR2 speakers is 7½" x 33½" (191mm x 851mm). There must be at least 37/8" (98mm) depth within the wall cavity for the speaker.
- Position the included cutout template where the speaker is to be located and pencil an outline on the wall.
 - If you are unsure about obstructions, drill 2 – 4 small holes along the outline's centerline and insert a coat hanger wire into each hole to feel-around for possible obstructions.

5. Cut the mounting hole using a keyhole or drywall saw, and run the speaker wire from the mounting hole to the amplifier location.
 - Consult local building codes before running speaker wires through walls.

Installation

Sonance Cinema Series speakers features an integral RotoLock® mounting system for quick mounting directly into existing walls.

1. Strip ¼" – ½" of insulation from each speaker lead. Twist the strands or tin the exposed wire with solder to ensure that there are no stray strands. (Stray strands that touch each other can cause a short-circuit that can damage the amplifier.)
2. The speaker's connector posts are spring-loaded. Push the top of each connector post down to open the connector and insert the exposed wires into the holes in the posts.
 - The speaker's positive post is labeled with a red dot; the negative post is labeled with a black dot. Double-check that you connected amplifier "+" to speaker "+" and amplifier "-" to speaker "-". (See Figure 4.)

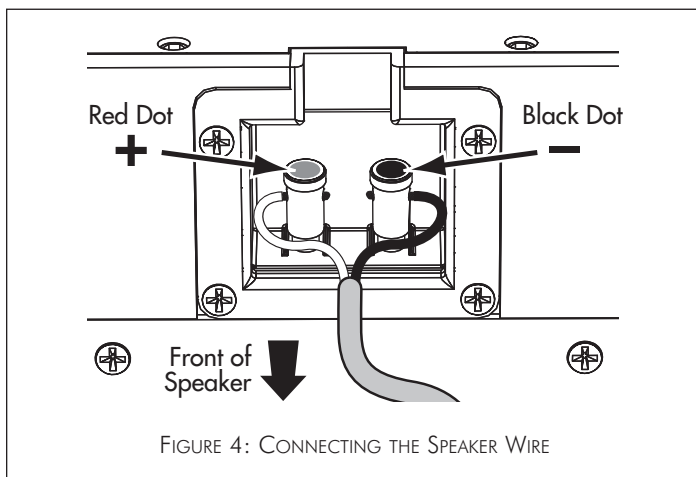

FIGURE 4: CONNECTING THE SPEAKER WIRE

3. Make sure all the RotoLock clamps are fully retracted into their recesses in the speaker box. Insert the speaker into the hole in the wall (see Figure 5, next column). The RotoLock system can accommodate a maximum wall material thickness of 1¼".
4. Using the supplied allen wrench, tighten the screws on the front of the speaker baffle. (The LCR1 and SUR1 each have four screws; the LCR2 and SUR2 each have 8 screws — see Figure 6, next column.) The RotoLock clamps will automatically rotate into position and begin clamping the speaker.
 - When you notice resistance on the screws the speaker has been clamped successfully.

IMPORTANT: Always use low-torque settings when tightening RotoLock clamps; NEVER over-tighten.

NOTE: ADJUSTING THE TENSION OF THE ROTOLOCK CLAMPS SO THAT THE SPEAKER FRAME IS FLAT WILL HELP ENSURE THAT THE GRILLE CONTACTS THE WALL ALL THE WAY AROUND THE SPEAKER FOR A PROPER FIT.

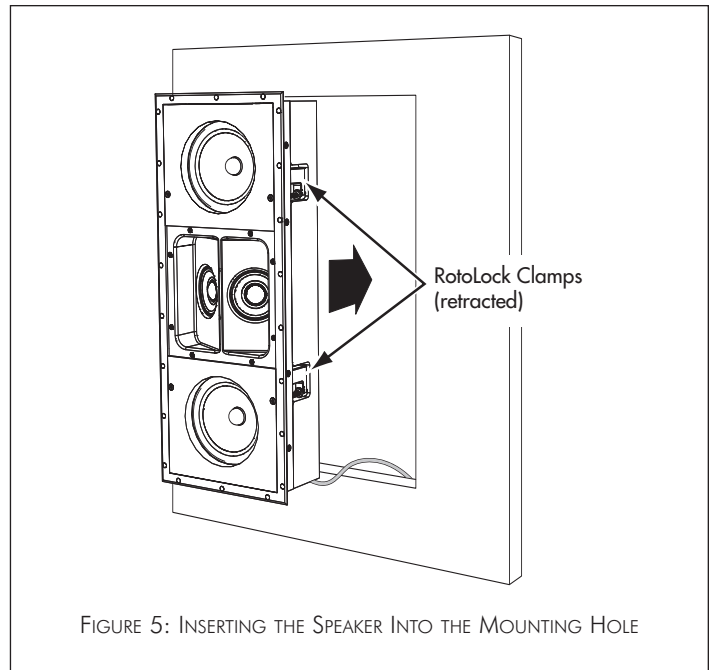

FIGURE 5: INSERTING THE SPEAKER INTO THE MOUNTING HOLE

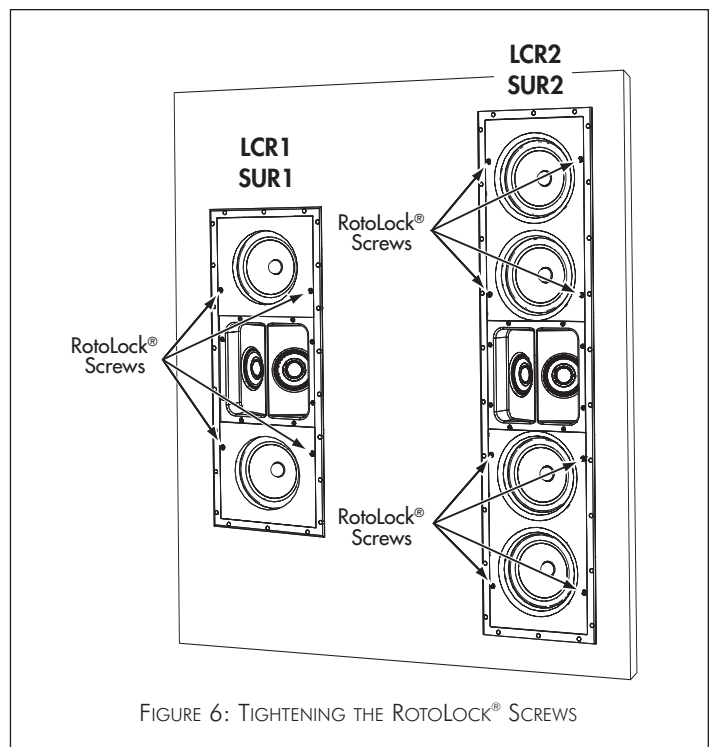
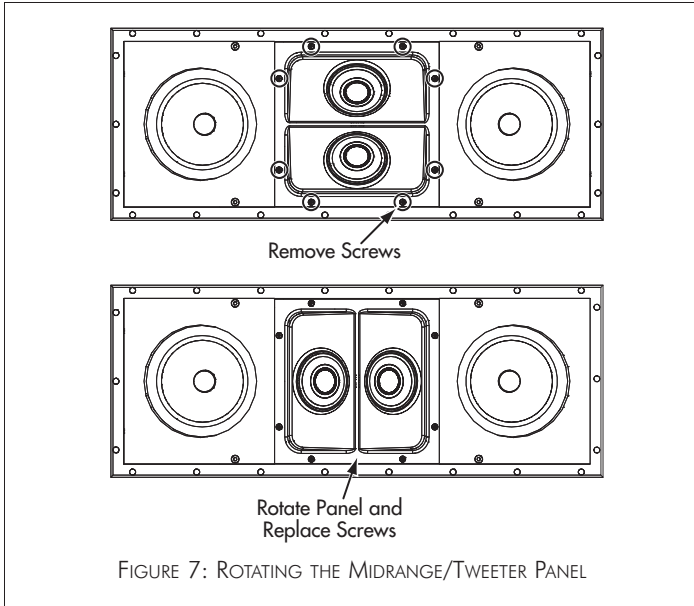

FIGURE 6: TIGHTENING THE ROTOLOCK® SCREWS

5. If you have installed Cinema SUR1 or Cinema SUR2 speakers horizontally, you must rotate the speaker's midrange/tweeter panel to maintain proper performance:
 - a) Remove the six screws that attach the midrange/tweeter panel to the speaker baffle.
 - b) Pull the midrange/tweeter panel away from the speaker baffle.
 - c) Rotate the panel 90°, re-install it on the speaker baffle and replace the six screws.

See Figure 7, on page 3.



- The new micro flange grille is held in place by several small, powerful magnets on the speaker frame. Place the grille against the speaker and the magnets will hold it firmly in place. When properly installed, the grille flange should make contact with the wall all the way around the speaker.

Painting the Speakers and Grilles

Please refer to the included *Painting Instructions* sheet.

Specifications

LCR1

Tweeter:	1" (25mm) silk dome, ferrofluid-cooled
Midrange:	4" (100mm) carbon fiber/Rohacell® laminated cone with a rubber surround
Woofers:	Two 5¼" (133mm) carbon fiber/Rohacell® laminated cones with rubber surrounds
Frequency Response:	70Hz – 20kHz ±3dB
Impedance:	6 ohms nominal; 4 ohms minimum
Power Handling:	5 watts minimum; 150 watts maximum
Sensitivity:	90dB SPL (2.83V/1 meter)
Grille Material:	Perforated steel
Dimensions (W x H x D):	8 7/8" x 21 3/4" x 3 7/8" (225mm x 553mm x 98mm)
Cutout Dimensions (W x H):	7 1/2" x 20 1/2" (191mm x 521mm)
Shipping Weight:	19 lbs (8.6kg) each

Specifications (continued)

SUR1

Tweeter:	Two 1" (25mm) silk domes, ferrofluid-cooled
Midrange:	Two 3" (76mm) carbon fiber/Rohacell® laminated cones with rubber surrounds
Woofers:	Two 5¼" (133mm) carbon fiber/Rohacell® laminated cones with rubber surrounds
Frequency Response:	70Hz – 20kHz ±3dB
Impedance:	6 ohms nominal; 4 ohms minimum
Power Handling:	5 watts minimum; 150 watts maximum
Sensitivity:	90dB SPL (2.83V/1 meter)
Grille Material:	Perforated steel
Dimensions (W x H x D):	8 7/8" x 21 3/4" x 3 7/8" (225mm x 553mm x 98mm)
Cutout Dimensions (W x H):	7 1/2" x 20 1/2" (191mm x 521mm)
Shipping Weight:	19 lbs (8.6kg) each

LCR2

Tweeter:	1" (25mm) silk dome, ferrofluid-cooled
Midrange:	4" (100mm) carbon fiber/Rohacell® laminated cone with a rubber surround
Woofers:	Four 5¼" (133mm) carbon fiber/Rohacell® laminated cones with rubber surrounds
Frequency Response:	70Hz – 20kHz ±3dB
Impedance:	6 ohms nominal; 4 ohms minimum
Power Handling:	5 watts minimum; 200 watts maximum
Sensitivity:	92dB SPL (2.83V/1 meter)
Grille Material:	Perforated steel
Dimensions (W x H x D):	8 7/8" x 34 7/8" x 3 7/8" (225mm x 886mm x 98mm)
Cutout Dimensions (W x H):	7 1/2" x 33 1/2" (191mm x 851mm)
Shipping Weight:	29 lbs (13.2kg) each

SUR2

Tweeter:	Two 1" (25mm) silk domes, ferrofluid-cooled
Midrange:	Two 3" (76mm) carbon fiber/Rohacell® laminated cones with rubber surrounds
Woofers:	Four 5¼" (133mm) carbon fiber/Rohacell® laminated cones with rubber surrounds
Frequency Response:	70Hz – 20kHz ±3dB
Impedance:	6 ohms nominal; 4 ohms minimum
Power Handling:	5 watts minimum; 200 watts maximum
Sensitivity:	92dB SPL (2.83V/1 meter)
Grille Material:	Perforated steel
Dimensions (W x H x D):	8 7/8" x 34 7/8" x 3 7/8" (225mm x 886mm x 98mm)
Cutout Dimensions (W x H):	7 1/2" x 33 1/2" (191mm x 851mm)
Shipping Weight:	29 lbs (13.2kg) each

Technical Assistance and Service

If you have questions about the operation or installation of this product, please call our Technical Assistance Department on any business day at 949.492.7777 from 7am to 5pm, pacific time.

If your speakers should need repair or service, contact your Sonance Authorized Dealer for help, or use the following procedure:

1. Prior to calling, note the product's model number, serial number, purchase date, and the name and address of the dealer where you purchased the product.
2. Contact our Technical Assistance Department at the above number(s) and describe the problem the unit is experiencing. If applicable, they will issue a Return Authorization Number.

IMPORTANT: YOU MUST HAVE PRIOR AUTHORIZATION TO RETURN YOUR SPEAKER TO SONANCE!

3. If you're directed to return the unit to Sonance for repair, pack the unit in its original shipping carton. If needed, you can obtain replacement packaging from us for a small charge. Note: it is best if you place the box into an additional outer "overcarton" before shipment to minimize a chance of theft in shipment. Please include a copy of the original bill of sale inside the package.
4. Contact a package delivery company such as United Parcel Service or Federal Express to arrange prepaid (not collect) shipping. Do not use the U.S. Postal Service.

IMPORTANT: Freight collect shipments will be refused.

5. Write the Return Authorization Number on the outside of the shipping carton.
6. Ship the packaged unit to:

Quality Assurance Department
Sonance
991 Calle Amanecer
San Clemente, CA 92673

Limited Lifetime Warranty Coverage (U.S. Only)

Sonance warrants to the original retail purchaser only that this Sonance product will be free from defects in materials and workmanship, provided the speaker was purchased from a Sonance Authorized Dealer.

Defective products must be shipped, together with proof of purchase, prepaid insured to the Authorized Sonance Dealer from whom they were purchased, or to the Sonance factory at the address listed on this instruction manual. Freight collect shipments will be refused. It is preferable to ship this product in the original shipping container to lessen the chance of transit damage. In any case, the risk or loss or

damage in transit is to be borne by the purchaser. If upon examination at the factory or Authorized Sonance Dealer it is determined that the unit was defective in materials or workmanship at any time during this warranty period, Sonance or the Authorized Sonance Dealer will, at its option, repair or replace this product at no additional charge, except as set forth below. If this model is no longer available and can not be repaired effectively, Sonance, at its sole option, may replace the unit with a current model of equal or greater value. In some cases where a new model is substituted, a modification to the mounting surface may be required. If mounting surface modification is required, Sonance assumes no responsibility or liability for such modification. All replaced parts and product become the property of Sonance. Products replaced or repaired under this warranty will be returned to the original retail purchaser, within a reasonable time, freight prepaid.

This Warranty does not include service or parts to repair damage caused by accident, disaster, misuse, abuse, negligence, inadequate packing or shipping procedures, commercial use, voltage inputs in excess of the rated maximum of the unit, or service, repair or modification of the product which has not been authorized or approved by Sonance. This Warranty also excludes normal cosmetic deterioration caused by environmental conditions. This Warranty will be void if the Serial Number on the product has been removed, tampered-with or defaced. This Warranty is in lieu of all other expressed warranties. If the product is defective in materials or workmanship as warranted above, the purchaser's sole remedy shall be repair or replacement as provided above. In no event will Sonance be liable for any incidental or consequential damages arising out of the use or inability to use the product, even if Sonance or an Authorized Sonance Dealer has been advised of the possibility of such damages, or for any claim by any other party.

Some states do not allow the exclusion or limitation of consequential damages, so the above limitation and exclusion may not apply. All implied warranties on the product are limited to the duration of this expressed Warranty. Some states do not allow limitation on the length of an implied warranty. If the original retail purchaser resides in such a state, this limitation does not apply.

Exclusions And Limitations

The warranty set forth above is in lieu of all other warranties, express or implied, of merchantability, fitness for a particular purpose, or otherwise. The warranty is limited to Sonance products registered herein and specifically excludes any damage to loudspeakers and other allied or associated equipment which may result for any reason from use with this product. Sonance shall, in no event, be liable for incidental or consequential damages arising from any breach of this warranty or otherwise. This warranty gives you specific legal rights, and you may have other rights which vary from state to state.



©2008 Sonance. All rights reserved. Sonance, Sonance Cinema and RotoLock are registered trademarks of Dana Innovations. Rohacell is a registered trademark of Degussa GmbH.

Due to continuous product improvement, all features and specifications are subject to change without notice. For the latest Sonance product specification information visit our website: www.sonance.com

Sonance • 991 Calle Amanecer • San Clemente, Ca 92673, USA
949.492.7777 • Fax: 949.361.5151 • Technical Support: 949.492.7777