

# INSTRUCTION MANUAL

## VISUAL PERFORMANCE® SERIES EXTREME SPEAKERS



### Introduction

Thank you for purchasing Sonance Visual Performance Series Extreme Speakers. These weatherproof 6" speakers can provide superior sound quality for high-humidity areas and are built to survive temperature extremes from  $-30^{\circ}\text{F}$  –  $+175^{\circ}\text{F}$  ( $-34^{\circ}\text{C}$  –  $+79^{\circ}\text{C}$ ). Their shallow depth makes them easy to install in a variety of challenging spaces. Visual Performance Extreme speakers provide excellent sound in yachts, saunas, steam rooms, and hot tub areas.

This manual covers the following speaker models: VP65 XT (rectangular), VP65R XT (round), VP65S XT (square), VP65R SST XT (round, Single-Stereo Technology®).

#### SAFETY WARNING:

THESE SPEAKERS HAVE FASTMOUNT® TABS THAT PREVENT THE SPEAKER FROM FALLING OUT OF THE MOUNTING HOLE DURING THE INSTALLATION PROCESS.

**THE EDGES OF THE FASTMOUNT TABS ARE VERY SHARP. USE CAUTION WHEN HANDLING THE SPEAKER.**

### Box Contents

Sonance VP65 XT, VP65R XT, and VP65S XT speaker boxes contain (2) speakers, (2) paint plugs (installed on the fronts of the speakers), (2) paintable grilles and (1) mounting cutout template.

Sonance VP65R SST XT speaker boxes contain (1) speaker, (1) plastic paint plug (installed on the front of the speaker), (1) paintable grille and (1) mounting cutout template.

### Speaker Placement

#### Stereo Speaker Placement (VP65 XT)

- Place the left and right speakers on the same wall, from 6 to 10 feet (1.8 – 3m) apart.
- If the listeners will be seated the speakers should be located 38 – 42 (97 – 107cm) inches from the floor.
- If listeners will be standing the speakers should be located 5 feet (1.5m) from the floor.
- The ideal listening distance will be between 4 and 10 feet (1.2 and 3m) away from the speakers. The best stereo performance will be midway between the speakers.

Use Figure 1 (next column) as a guide

#### Distributed Audio Placement (VP65R XT/VP65S XT/VP65R SST XT)

Sonance VP65R XT, VP 65S XT and VP65R SST XT in-ceiling speaker models provide excellent coverage in distributed audio systems from a wide variety of installation locations.

The table and illustration in Figure 2 show how far apart

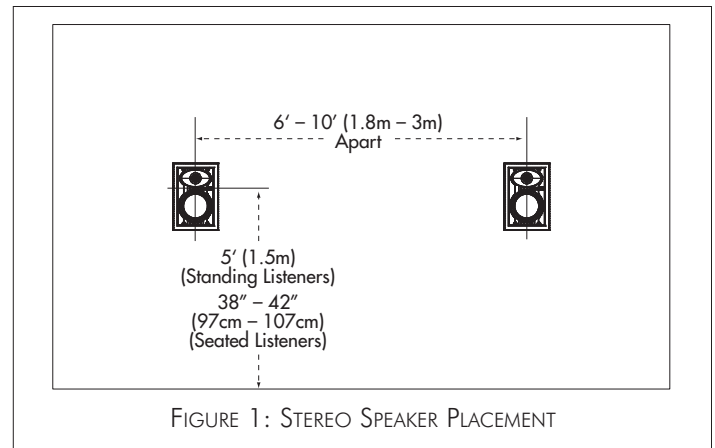

speakers can be placed at various ceiling heights while still providing good coverage for all listeners.

The VP65R SST XT reproduces both stereo channels from a single location, making it ideal for use in bathrooms, saunas, or in any location where a pair of stereo speakers would be impractical.

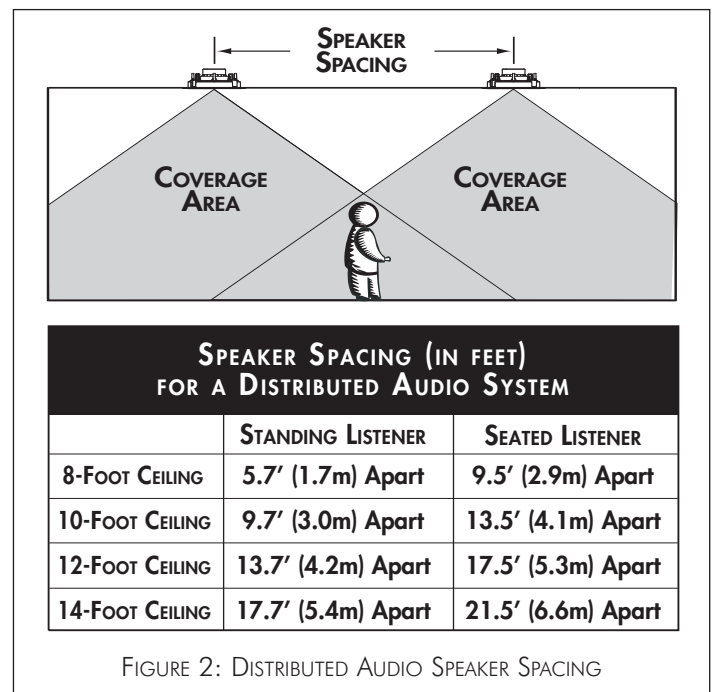

### Before Installation: Retrofit

- Determine the location for the speaker (see *Speaker Placement* on page 1).
- Perform an obstruction survey to be certain that there are no studs, conduit, pipes, heating ducts, pocket doors or air returns in the wall cavity that will interfere with the speaker.

- VP Extreme speakers require the following mounting cutouts:
  - VP65 XT: 6<sup>15/16</sup>" (176mm) wide by 10<sup>3/4</sup>" (273mm) high, with at least 2<sup>1/2</sup>" (64mm) of depth within the mounting cavity.
  - VP65R XT: 8<sup>1/4</sup>" (210mm) diameter, with at least 3<sup>1/2</sup>" (89mm) of depth within the mounting cavity.
  - VP65S XT: 8<sup>1/4</sup>" (210mm) wide by 8<sup>1/4</sup>" (210mm) high, with at least 3<sup>1/2</sup>" (89mm) of depth within the mounting cavity.
  - VP65R SST XT: 8<sup>1/4</sup>" (210mm) diameter, with at least 3<sup>1/2</sup>" (89mm) of depth within the mounting cavity.
- Position the included mounting cutout template where the speaker is to be located and pencil an outline on the wall or ceiling.
  - If you are unsure about obstructions, drill a small hole in the center of the outline and insert a coat hanger wire into the hole to feel-around for possible obstructions.
- Cut the mounting hole using tools appropriate for the construction, and run the speaker wires from the mounting hole to the amplifier location.
  - Consult local building codes before running speaker wires through walls.

## Installation

Sonance Visual Performance Series Extreme speakers feature exclusive FastMount® tabs and an integral RotoLock® mounting system for quick mounting directly into existing walls and ceilings.

**WARNING: THE EDGES OF THE FASTMOUNT TABS ARE VERY SHARP. USE CAUTION WHEN HANDLING THE SPEAKER.**

- Remove the paint plug from the speaker.
- Strip 1/4" – 1/2" (6mm – 13mm) of insulation from each speaker lead. Twist the strands or tin the exposed wire with solder to ensure that there are no stray strands. (Stray strands that touch each other can cause a short-circuit that can damage the amplifier.)
- The speaker's connector posts are spring-loaded. Push the top of each connector post down to open the connector and insert the exposed wires into the holes in the posts (see Figure 3).

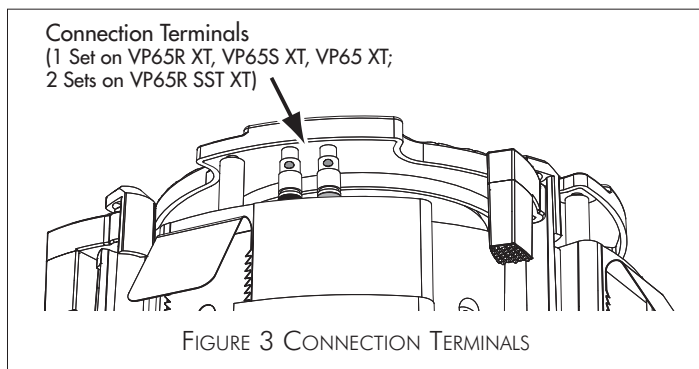

- The speaker's positive post is labeled with a red dot; the negative post is labeled with a black dot.
- The VP65R SST XT has two sets of connection terminals, located on opposite sides of the crossover board.
- After making all connections, double-check that you connected amplifier "+" to speaker "+" and amplifier "-" to speaker "-".

- As shipped, the RotoLock clamps can accommodate a maximum wall or ceiling material thickness of 1 1/4" (32mm).

NOTE: IF YOU'RE INSTALLING THE VP65R XT, VP65S XT, OR VP65R SST XT INTO CEILING MATERIAL THAT IS THICKER THAN 1 1/4" (32MM), YOU CAN REMOVE THE 'FEET' OF THE ROTOLOCK CLAMPS, WHICH WILL ALLOW YOU TO CLAMP THE SPEAKER TO CEILING MATERIAL THAT IS UP TO 1 3/4" (44MM) THICK. TO REMOVE THE CLAMP FEET, USE A SMALL SCREWDRIVER TO GENTLY RELEASE THE LOCKING LEVERS (FIGURE 4, LEFT). THEN REMOVE THE FEET FROM THE CLAMPS (FIGURE 4, RIGHT).

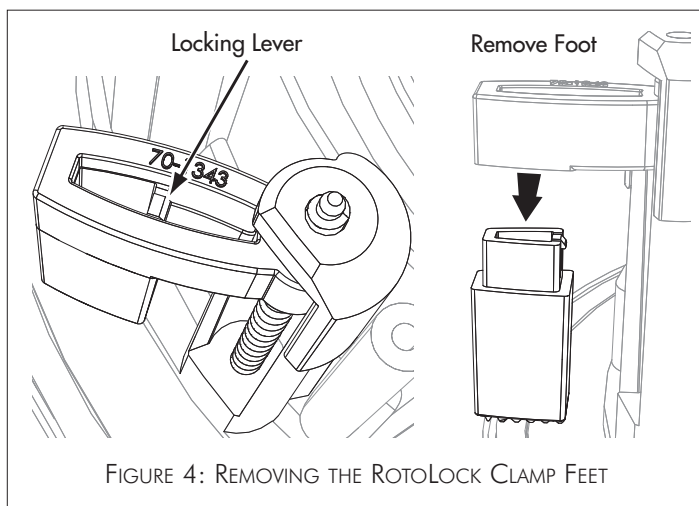

- Make sure all the RotoLock clamps are retracted so that they are tucked within the mounting hole's border. Insert the speaker into the mounting hole (Figure 5, left). The FastMount tabs will prevent the speaker from falling out of the mounting hole, allowing you to let go of the speaker to pick-up tools or other items (Figure 5, right).

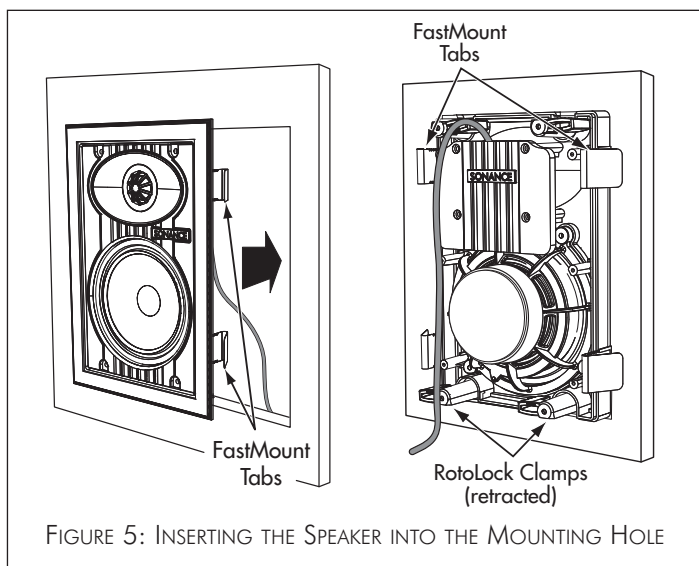

NOTE: THE FASTMOUNT TABS ARE DESIGNED FOR ONE-TIME USE ONLY. IF THE SPEAKER IS REMOVED FROM THE MOUNTING HOLE THE FASTMOUNT TABS WILL DISCONNECT AND REMAIN INSIDE THE WALL OR CEILING.

- Tighten the four screws on the front of the speaker baffle. The RotoLock clamps will automatically rotate into position and begin clamping the speaker (Figure 6, page 3).

# SONANCE VISUAL PERFORMANCE® EXTREME SPEAKERS

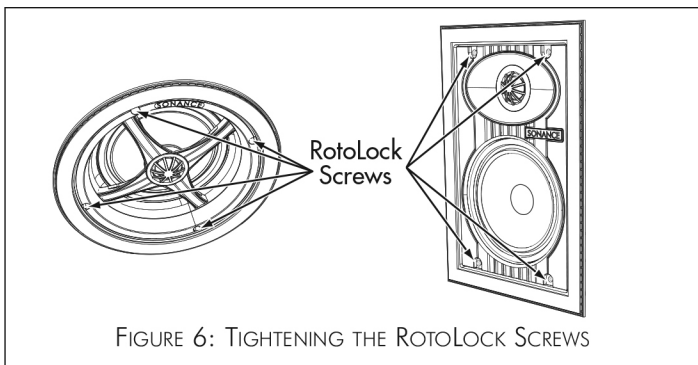

FIGURE 6: TIGHTENING THE ROTOLOCK SCREWS

- When you notice resistance on the screws the speaker has been clamped successfully.

**IMPORTANT: ALWAYS USE LOW-TORQUE SETTINGS; NEVER OVER-TIGHTEN.**

NOTE: ADJUSTING THE TENSION OF THE ROTOLOCK CLAMPS SO THAT THE SPEAKER FRAME IS FLAT WILL HELP ENSURE THAT THE GRILLE CONTACTS THE WALL ALL THE WAY AROUND THE SPEAKER FOR A PROPER FIT.

- The new micro-trim grille is held in place by several small, powerful magnets on the rear of the grille. Place the grille against the speaker and the magnets will hold it firmly in place. When the grille is properly installed, the grille trim should make contact with the mounting surface all the way around the speaker.

## Painting the Grilles

See the accompanying instruction sheet for painting instructions.

## Environmental Specifications

Maximum Heat:	+175°F (+79°C)
Maximum Cold:	-30°F (-34°C)
Maximum Humidity:	99% (120°F/49°C) 95% (-30°F/-34°C)

These speakers meet or exceed the following:

Salt Spray:	ASTM-B117
UV Test:	ASTM-G23H
IEC/CEE	
Water Splashing Test:	IP-X4
Vibration Test:	ASTM D5112-98 and ASTM D3580-95

## Performance Specifications

### VP65 XT

Tweeter:	1" (25mm) polyurethane dome
Woofers:	6½" (165mm) injection-molded polypropylene/graphite cone, with integral Santoprene® surround
Frequency Response:	55Hz – 20kHz ±3dB
Impedance:	8 ohms nominal; 6 ohms minimum
Power Handling:	5 watts minimum; 130 watts maximum
Sensitivity:	89dB SPL (2.83V/1 meter)
Grille Material:	Powder-coated stainless steel
Dimensions (W x H x D):	8¾" x 12¼" x 2½" (213mm x 311mm x 64mm)
Cutout Dimensions (W x H):	6¹⁵⁄₁₆" x 10¾" (176mm x 273mm)
Shipping Weight:	12 lbs (5.4kg) pair

### VP65R XT

Tweeter:	1" (25mm) polyurethane dome
Woofers:	6½" (165mm) injection-molded polypropylene/graphite cone, with integral Santoprene® surround
Frequency Response:	55Hz – 20kHz ±3dB
Impedance:	8 ohms nominal; 6 ohms minimum
Power Handling:	5 watts minimum; 130 watts maximum
Sensitivity:	89dB SPL (2.83V/1 meter)
Grille Material:	Powder-coated stainless steel
Dimensions (Dia x D):	9¾" x 3½" (248mm x 89mm)
Cutout Dimensions (Dia):	8¼" (210mm)
Shipping Weight:	12 lbs (5.4kg) pair

### VP65S XT

Tweeter:	1" (25mm) polyurethane dome
Woofers:	6½" (165mm) injection-molded polypropylene/graphite cone, with integral Santoprene surround
Frequency Response:	55Hz – 20kHz ±3dB
Impedance:	8 ohms nominal; 6 ohms minimum
Power Handling:	5 watts minimum; 130 watts maximum
Sensitivity:	89dB (SPL 2.83V/1 meter)
Grille Material:	Powder-coated stainless steel
Dimensions (H x W x D):	9⁷⁄₈" x 9⁷⁄₈" x 3½" (251mm x 251mm x 89mm)
Cutout Dim. (W x H):	8¼" x 8¼" (210mm x 210mm)
Shipping Weight:	12 lbs. (5.4kg) pair

### VP65R SST XT

Tweeter:	Two 1" (25mm) polyurethane domes
Woofers:	6½" (165mm) injection-molded polypropylene/graphite cone, with integral Santoprene® surround, dual voice coil
Frequency Response:	55Hz – 20kHz ±3dB
Impedance:	8 ohms nominal; 6 ohms minimum
Power Handling:	5 watts minimum; 130 watts maximum
Sensitivity:	89dB SPL (2.83V/1 meter)
Grille Material:	Powder-coated stainless steel
Dimensions (Dia x D):	9¾" x 3½" (248mm x 89mm)
Cutout Dimensions (Dia):	8¼" (210mm)
Shipping Weight:	4.5 lbs (2.1kg) each

## LIMITED FIVE (5) YEAR WARRANTY

Sonance warrants to the first end-user purchaser that this Sonance-brand product ("Product"), when purchased from an authorized Sonance Dealer/Distributor, will be free from defective workmanship and materials for the period stated below. Sonance will at its option and expense during the warranty period, either repair the defect or replace the Product with a new or remanufactured Product or a reasonable equivalent.

## EXCLUSIONS

TO THE EXTENT PERMITTED BY LAW, THE WARRANTY SET FORTH ABOVE IS IN LIEU OF, AND EXCLUSIVE OF, ALL OTHER WARRANTIES, EXPRESS OR IMPLIED, AND IS THE SOLE AND EXCLUSIVE WARRANTY PROVIDED BY SONANCE. ALL OTHER EXPRESS AND IMPLIED WARRANTIES, INCLUDING THE IMPLIED WARRANTIES OF MERCHANTABILITY, IMPLIED WARRANTY OF FITNESS FOR USE, AND IMPLIED WARRANTY OF FITNESS FOR A PARTICULAR PURPOSE ARE SPECIFICALLY EXCLUDED. No one is authorized to make or modify any warranties on behalf of Sonance.

The warranty stated above is the sole and exclusive remedy and Sonance's performance shall constitute full and final satisfaction of all obligations, liabilities and claims with respect to the Product. IN ANY EVENT, SONANCE SHALL NOT BE LIABLE FOR CONSEQUENTIAL, INCIDENTAL, ECONOMIC, PROPERTY, BODILY INJURY, OR PERSONAL INJURY DAMAGES ARISING FROM THE PRODUCT, ANY BREACH OF THIS WARRANTY OR OTHERWISE.

This warranty statement gives you specific legal rights, and you may have other rights which vary from state to state. Some states do not allow the exclusion of implied warranties or limitations of remedies, so the above exclusions and limitations may not apply. If your state does not allow disclaimer of implied warranties, the duration of such implied warranties is limited to period of Sonance's express warranty.

---

Your Product Model and Description: Visual Performance Extreme Speakers

Warranty Period for this Product: Five (5) years from the date on the original sales receipt or invoice or other satisfactory proof of purchase.

Additional Limitations and Exclusions from Warranty Coverage: The warranty described above is non-transferable, applies only to the initial installation of the Product, does not include installation of any repaired or replaced Product, does not include damage to allied or associated equipment which may result for any reason from use with this Product, and does not include labor or parts caused by accident, disaster, negligence, improper installation, misuse (e.g. overdriving the amplifier or speaker, excessive heat or cold or humidity), or from service or repair which has not been authorized by Sonance.

Obtaining Authorized Service: To qualify for the warranty, you must contact your authorized Sonance Dealer/Installer or call Sonance Customer Service at (800) 582-0772 within the warranty period, must obtain a return merchandise number (RMA), and must deliver the Product to Sonance shipping prepaid during the warranty period, together with the original sales receipt, or invoice or other satisfactory proof of purchase.



©2009 Sonance. All rights reserved.

Sonance, Sonance Visual Performance, Single Stereo Technology, RotoLock and FastMount are registered trademarks of Dana Innovations.

Santoprene is a registered trademark of Monsanto Corporation.

Due to continuous product improvement, all features and specifications are subject to change without notice.

For the latest Sonance product specification information visit our website: [www.sonance.com](http://www.sonance.com)

SONANCE • 212 Avenida Fabricante • San Clemente, CA 92672-7531 USA

(800) 582-7777 or (949) 492-7777 • FAX: (949) 361-5151 • Technical Support: (800) 582-0772

[www.sonance.com](http://www.sonance.com)