

**SAMSON®**

**auro** Active Subwoofer

**D1800**



**1000 Watt 18" Powered Subwoofer**

**OWNERS MANUAL**

# Important Safety Information



**AVIS**  
**RISQUE DE CHOC ÉLECTRONIQUE -**  
**NE PAS OUVRIR**

CAUTION: TO REDUCE THE RISK OF ELECTRIC SHOCK, DO NOT REMOVE COVER (OR BACK). NO USER-SERVICEABLE PARTS INSIDE. REFER SERVICING TO QUALIFIED SERVICE PERSONNEL.



This lightning flash with arrowhead symbol within an equilateral triangle is intended to alert the user to the presence of non-insulated “dangerous voltage” within the product’s enclosure that may be of sufficient magnitude to constitute a risk of electric shock.



The exclamation point within an equilateral triangle is intended to alert the user to the presence of important operating and maintenance instructions in the literature accompanying the appliance.



If you want to dispose this product, do not mix it with general household waste. There is a separate collection system for used electronic products in accordance with legislation that requires proper treatment, recovery and recycling.

Private household in the 25 member states of the EU, in Switzerland and Norway may return their used electronic products free of charge to designated collection facilities or to a retailer (if you purchase a similar new one).

For Countries not mentioned above, please contact your local authorities for a correct method of disposal.

By doing so you will ensure that your disposed product undergoes the necessary treatment, recovery and recycling and thus prevent potential negative effects on the environment and human health.

# Important Safety Information

1. Read these instructions.
2. Keep these instructions.
3. Heed all warnings.
4. Follow all instructions.
5. This apparatus shall not be exposed to dripping or splashing liquid and no object filled with liquid, such as a vase, should be placed on the apparatus.
6. Clean only with a dry cloth.
7. Do not block any of the ventilation openings. Install in accordance with the manufacturer's instructions.
8. Do not install near any heat sources such as radiators, heat registers, stoves, or other apparatuses (including amplifiers) that produce heat.
9. Only use attachments/accessories specified by the manufacturer.
10. Unplug this apparatus during lightning storms or when not in use for long periods of time.
11. Do not override the intended purpose of the polarized or grounding-type plug. A polarized plug has two blades, with one wider than the other. A grounding-type plug has two blades and a third grounding prong. The wide blade, or third prong, is provided for your safety. If the provided plug does not fit your outlet, consult an electrician to replace the obsolete outlet.
12. Protect the power cord from being walked on or pinched, particularly at the prongs, convenience receptacles, the point where they exit from the apparatus.
13. Use only with the cart stand, tripod bracket, or table specified by the manufacture, or sold with the apparatus. When a cart is used, utilize caution when moving the cart/apparatus combination to avoid injury from tip-over.
14. Refer all servicing to qualified service personnel. Servicing is required if the apparatus has been damaged in any way, such as power-supply cord or plug breakage, damage due to liquid or objects falling onto the apparatus, exposure to rain or moisture, or if the apparatus does not operate normally, or has been dropped.
15. **POWER ON/OFF SWITCH:** For products with a power switch, the power switch **DOES NOT** break the connection from the mains.
16. **MAINS DISCONNECT:** The plug should remain readily operable. For rack-mount or installation where plug is not accessible, an all-pole mains switch with a contact separation of at least 3 mm in each pole shall be incorporated into the electrical installation of the rack or building.
17. **FOR UNITS EQUIPPED WITH EXTERNALLY ACCESSIBLE FUSE RECEPTACLE:** Replace fuse with same type and rating only.
18. **MULTIPLE-INPUT VOLTAGE:** This equipment may require the use of a different line cord, attachment plug, or both, depending on the available power source at installation. Connect this equipment only to the power source indicated on the equipment rear panel. To reduce the risk of fire or electric shock, refer servicing to qualified service personnel or equivalent.



---

# Table of Contents

Introduction . . . . .	1
Auro D1800 Features . . . . .	2
Quick Start . . . . .	3
Controls and Functions . . . . .	4
Configuring Your Speaker System . . . . .	6
Operating the Auro D1800. . . . .	7
Phase and Polarity . . . . .	9
Connections . . . . .	10
Caster Installation . . . . .	10
Specifications . . . . .	11

Copyright 2011 - Samson Technologies Corp.  
Samson Technologies Corp.  
45 Gilpin Avenue  
Hauppauge, New York 11788-8816  
Phone: 1-800-3-SAMSON (1-800-372-6766)  
Fax: 631-784-2201  
[www.samsontech.com](http://www.samsontech.com)  
V1.1

---

## Introduction

Thank you for purchasing the Samson Auro D1800 professional, powered subwoofer. The Auro D1800 is a compact and powerful speaker cabinet featuring an 18" long excursion driver, complemented by a 1000 Watt class-D power amplifier. The subwoofer offers both stereo full-range and high-pass outputs for running your satellite speakers or linking multiple D1800 cabinets together to create larger sound reinforcement systems.

The Auro cabinet is constructed with 18 mm plywood, heavy-duty textured black paint, oversized steel handles, and features large casters offering excellent protection against wear and tear, for truly portable audio. The D1800 active subwoofer is ideal for live music, DJ, and installed sound applications, or anywhere serious power and superior sound quality are desired.

In these pages, you'll find a detailed itemization of the features of the Auro powered subwoofer, as well as a description of its controls, step-by-step instructions for its setup and use, and full specifications. You'll also find a warranty card enclosed—please don't forget to fill it out and mail it in so that you can receive online technical support, and so that we can send you updated information about this and other Samson products. Also, be sure to check out our website ([www.samsontech.com](http://www.samsontech.com)) for complete information about our full product line.

With proper care and adequate air circulation, your Auro D1800 will operate trouble-free for many years. We recommend you record your serial number in the space provided below for future reference.

Serial number: \_\_\_\_\_

Date of purchase: \_\_\_\_\_

Should your unit ever require servicing, a Return Authorization (RA) number must be obtained before shipping your unit to Samson. Without this number, the unit will not be accepted. Please call Samson at 1-800-3SAMSON (1-800-372-6766) for an RA number prior to shipping your unit. Please retain the original packing materials and, if possible, return the unit in its original carton and packing materials. If you purchased your Samson product outside the United States, please contact your local distributor for warranty and service information.

---

## Auro D1800 Features

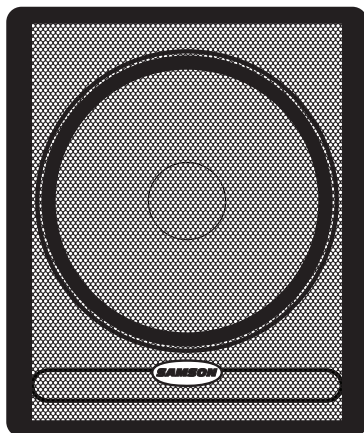

The Samson Auro D1800 powered subwoofer utilizes the latest technology in loud-speaker and power amplifier design. Here are some of its main features:

- Heavy-duty, 18" low frequency transducer with Butyl rubber surround
- Built-in 1000 Watt, highly efficient class-D power amplifier
- Dual balanced XLR inputs for mono or stereo operation
- Stereo balanced XLR full range and high pass outputs
- Internal 126Hz active crossover
- Selectable polarity and variable volume control
- Heavy-duty, rear mounted casters
- Two large, steel carry handles
- 35 mm pole mount receptacle
- Heavy-duty, steel grill
- 18 mm plywood construction, internally braced
- Durable textured black polyurethane paint

---

## Quick Start

The following steps will help you set up your Auro D1800 active subwoofer.

- Unpack the Auro D1800 and included components. Be sure to save the packaging in case you ever move, or need to send the unit for service.
- Set the Auro D1800 subwoofer and satellite speaker(s) appropriately for the performance venue. The D1800 has a 1 $\frac{3}{8}$ " speaker pole receptacle, so you can mount a satellite speaker on top of the D1800 using a satellite mounting pole (such as the Samson TS20).
- Turn the Level control on all speakers fully counterclockwise.
- Turn the Power switch to the OFF position on all speakers.
- Connect a line-level signal from your mixer (or other source) to the XLR Input jack on the Auro D1800. If you are using a single subwoofer with stereo satellite speakers, connect the left and right output of the mixer to the stereo XLR Input jacks on the Auro D1800.
- Connect an XLR cable from the High Pass output of the Auro D1800 to the line input of your satellite speaker(s).
- Plug the supplied power cable into an AC outlet.  
*Note:* Always make sure that the AC outlet used with this unit is configured with the correct voltage, as indicated on the rear panel of the Auro loudspeaker.
- Turn the Power switch on your D1800 and satellite speaker(s) to the ON position.
- Run an audio signal (like music from a CD) from your mixer, and check that you are getting good level using the mixer's output meter.
- Slowly raise the satellite speaker(s) level control until you have reached a comfortable level. Then raise the Auro D1800 Level control until you have reached a level that sits well within the rest of the mix.
- If the volume from the D1800 gets too loud, or you notice the Peak indicator blinking frequently, turn down the Level control on the Auro D1800 a little until the Peak indicator does not light, or only lights occasionally with signal peaks.

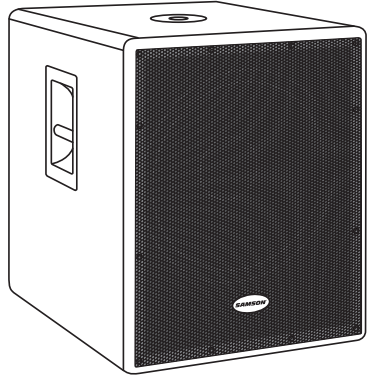

## Controls and Functions

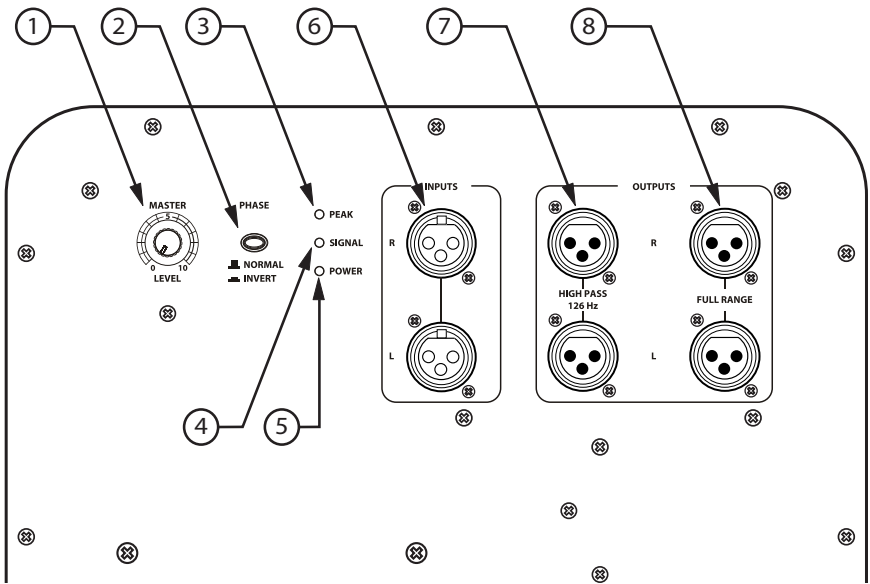

1. **MASTER LEVEL** - This control adjusts the overall signal level at the input of the D1800's power amplifier. This control does not affect the signal sent to the Full Range and High Pass Outputs.
2. **PHASE Switch** - Use this switch to set the polarity of the amplified signal. In the out (NORMAL) setting, there is no change to the signal. When the switch is pressed to the in (INVERT) setting, the signal's polarity is changed by 180°. The setting of the Polarity switch has no effect on the signal sent to the Full Range and High Pass Outputs.
3. **PEAK Indicator** - This red LED lights when the amp is near the clipping point. If the Peak indicator lights frequently, turn down the Level control on the Auro subwoofer or turn down the signal at the source, until the indicator does not light anymore, or lights only occasionally with signal peaks.
4. **SIGNAL Indicator** - The green SIGNAL LED lights whenever signal is present at the D1800's inputs.
5. **POWER Indicator** - This LED lights RED when the amp is active.
6. **INPUTS (L and R)** - The D1800 features electronically balanced female XLR stereo line inputs. The left (L) and right (R) input signals are mixed together before they are routed to the internal amplifier.
7. **HIGH PASS Outputs (L and R)** - Electronically balanced male XLR stereo line outputs, for sending the signal present at the INPUTS to your full range main loudspeakers. The signal is first processed by the internal 12dB per octave, 126Hz Linkwitz-Riley active crossover before reaching the outputs.



## Controls and Functions

**8. FULL RANGE Outputs (L and R)** - Electronically balanced full range male XLR stereo line outputs. These outputs can be used to connect another subwoofer, or send full range signal to your main PA loudspeakers.

**9. AC Power Inlet and Fuse Sled** - Connect the supplied standard IEC AC power cable here. Be sure to confirm and install the properly rated fuse when replacing the fuse or changing the operating voltage.

**10. Voltage Switch** - Slide to change the operating voltage from 115 to 230 volts.

**11. POWER Switch** - Switches on the Auro D1800's main power.

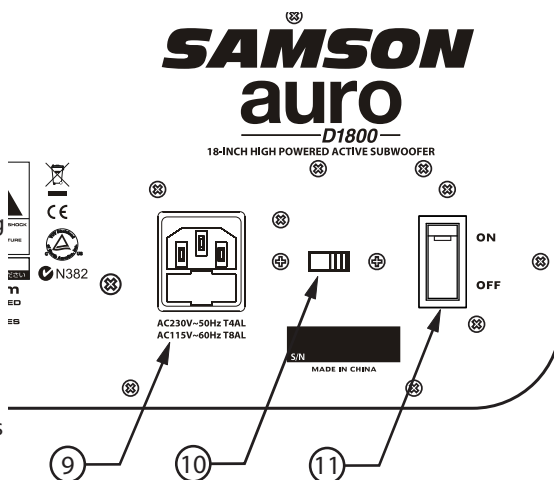

---

## Configuring Your Speaker System

Before you start plugging in cables, you should take a minute to decide how you want to interface your new Auro D1800. Most system set-ups fall into one of two categories: Stereo or Mono sub operation.

### Mono Sub Operation

In most cases, a common sub (or mono) bass setup is preferable. Low frequencies produced by a subwoofer tend to be non-directional. Since low frequency waves take so much space to develop, it is difficult for the ear to tell if sub bass is coming from the left or right side (unless, of course you're in a very large room). Because of this phenomenon, just about all sub bass material is mixed in mono.



### Stereo Sub Operation

In larger rooms, as well as in theatres and theme park installations (for low frequency special audio effects), two Auro D1800's can be used in stereo. For additional low-end, you can daisy chain a pair of Auro D1800 subwoofers to each side of your speaker system.

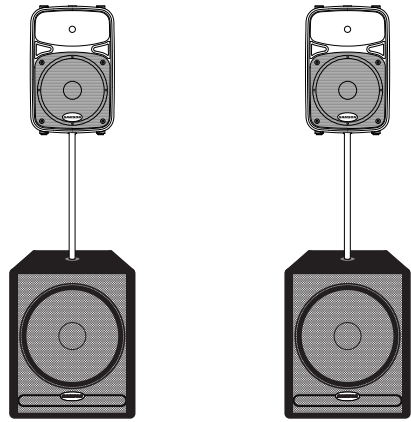

---

## Operating the Auro D1800

The Auro D1800 is a perfect addition to any pair of powered full range enclosures (like the Samson Auro D412 and Auro D415). Below is a typical system set-up using the D1800 with a mixer and a pair of powered satellite loudspeakers. The D1800's inputs and outputs utilize industry standard XLR connectors. For a detailed wiring diagram, please see the section "Connections" on page 10. Follow the steps below to set up your system.

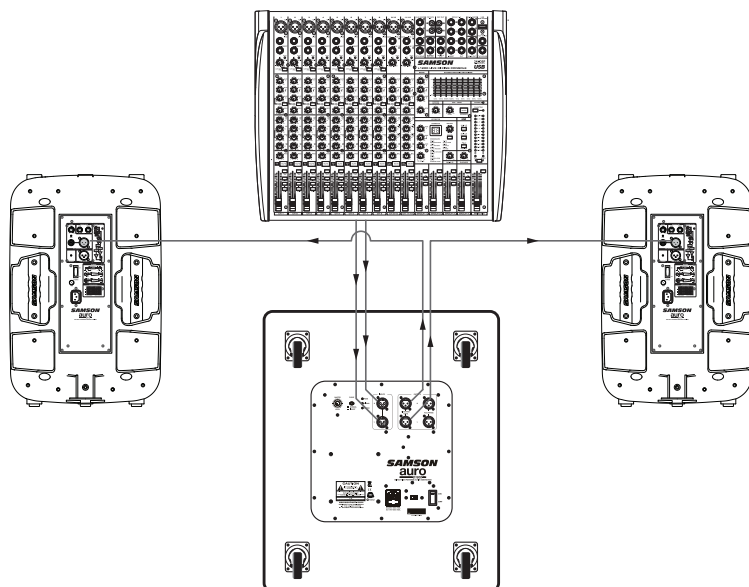

- Lower your mixer's master outputs all the way off.
- Connect the mixer's left output to the D1800's left input, and the mixer's right output to the D1800's right input.
- Now, connect the D1800's left High Pass output to the line input of the left side powered satellite, or power amplifier (if using passive speakers) and the D1800's right High Pass output to the line input of the right side satellite or power amplifier (if using passive speakers).
- Now, set the level of your powered satellites up to normal operating level. Run an audio signal (like music from a CD) through your mixer, and raise the level to a comfortable listening volume.
- Next, slowly raise the D1800 Level control and listen to the low frequency output. Adjust the D1800's Level control to the desired low frequency output.
- Now, when you raise and lower your mixer's output, the D1800 and satellites will track at the same relative volume.

---

## Operating the Auro D1800

To create a stereo full range audio system, two D1800s can be used with any pair of powered full range enclosures (like the Samson Auro D412 and D415). Below is a typical system set-up using two D1800s with a mixer and a pair of powered satellite loudspeakers. The D1800's inputs and outputs utilize industry standard XLR connectors. For a detailed wiring diagram, please see the section "Connections" on page 10. Follow the steps below to set up your system.

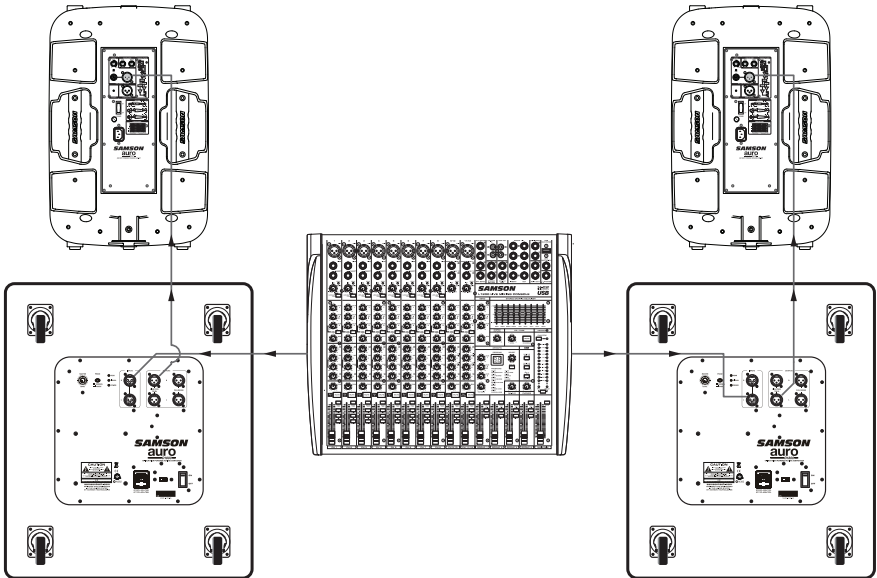

- Lower your mixer's master outputs all the way off.
- Connect the mixer's left output to the left-side D1800's left input, and the mixer's right output to the right-side D1800's right input.
- Now connect the left-side D1800's left High Pass output to the line input of the left powered satellite, and right-side D1800's right output to the line input of the right satellite.
- Now, set the level of your powered satellites up to normal operating level. Run an audio signal (like music from a CD) through your mixer, and raise the level to a comfortable listening volume.
- Next, slowly raise the D1800s' Level controls and listen to the low frequency output. Adjust the two D1800s to the desired level of low frequency output.
- Now when you raise and lower your mixer's output, the D1800s and satellites will track at the same relative volume.

## Phase and Polarity

A speaker reproduces sound by converting electrical signal into physical vibration. This physical vibration, in turn, pushes air to create sound waves. When setting up your speaker system, the goal is to have all speakers moving in phase, with the in and out movement of the speakers synchronized.

This produces an even sound across all audible frequencies. If the subwoofer is out of phase with the full range front of house speakers, you may notice decreased bass response, or even bass frequency cancellation where satellite and subwoofer frequency responses overlap. Many times this phenomenon is very subtle, but it can produce the effect of “holes” in the music, and diminished bass frequencies.

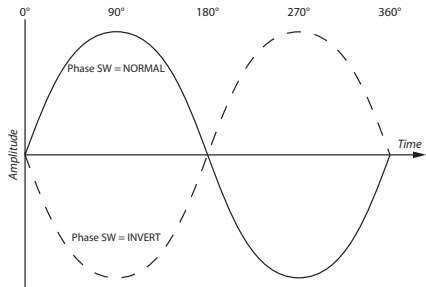

Ideally, your Auro D1800 subwoofer should be positioned on the same plane as your satellite speakers. In reality, we know this is difficult, as there are restrictions when setting up a PA system due to space limitations, speaker stand configuration, or even speaker cabinet shape. To compensate for these obstacles, the Auro D1800 features a Phase switch, which allows you to reverse the polarity of the subwoofer relative to the source signal. This enables you to put the D1800 in phase with the rest of your PA system, or 180° out of phase.

To determine if the audio produced by your D1800 is in phase with the rest of your PA system, play an audio track containing a lot of bass frequencies through your speaker system. Stand at a good listening distance, where you can clearly hear the audio from the subwoofer(s) and mains speaker(s), and listen until you believe you have a good gauge of the level of bass frequencies. Press the Phase switch on the D1800 to reverse the phase by 180°, and move back to your original listening position (if possible, have someone else press the Phase switch so that you can stand in the exact same location). Compare the overall level of the bass frequencies between the two settings. The correct setting will result in more bass frequencies. If the situation allows, you can fine-tune the phase of your D1800 to your satellite speakers by moving the relative position of the subwoofer closer or further away from the listening position.

# Connections

The Auro D1800 features balanced inputs and outputs with industry standard XLR connectors. Whenever possible, use high quality balanced connections to other equipment to suppress interference. See the wiring diagram below for Auro D1800 connectors.

## XLR to XLR Balanced

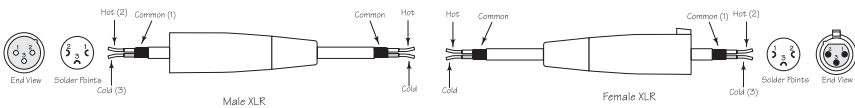

## XLR to Balanced 1/4-Inch

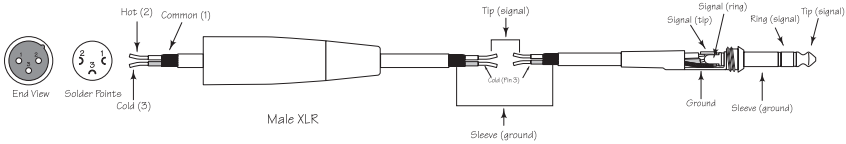

# Caster Installation

- Locate one caster and four each of the supplied screws and lock washers.
- Hold the caster in place and hand start the screws. Be careful to ensure that the screws are on the proper thread chase. Do not push down on the screws, as it could dislodge the internal threaded t-nuts.
- Use a screwdriver to tighten the four screws.
- Repeat the steps above for the remaining three casters.

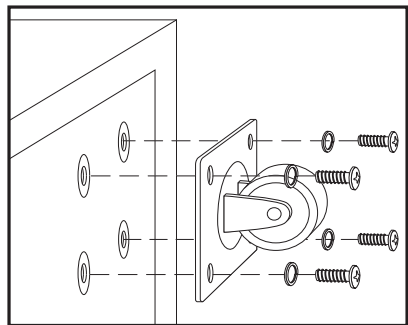

---

# Specifications

## Amplifier

RMS Power	500 watts
Peak Power	1000 watts
THD	< 0.1%
Design	Class-D

## Transducer

Driver	18" paper cone, 3" voice coil diameter
Sensitivity	95dB SPL @ 1w/1m

## Acoustic Performance

Frequency Response	30Hz- 135Hz (+/-3 dB)
Max. SPL	125 dB SPL @ 1000 watts

## Electronic Crossover

Crossover Type	24 dB/oct Linkwitz-Riley
Crossover Frequency	126 Hz

## Controls and Connectors

Inputs (L and R)	Balanced Female XLR - Line Level
High Pass Outputs (L and R)	Balanced Male XLR - Line Level
Full Range Outputs (L and R)	Balanced Male XLR - Line Level
Controls	Master Level Rotary, Phase Switch
Indicators	Peak, Signal, Power

## Power Supply

Power Consumption	645 W max.
AC Connector	3-pin IEC 250 VAC, 20 A male
Fuse	100 - 115 VAC T8AL / 250 V 220 - 240 VAC T4AL / 250 V

## Enclosure

Construction	18 mm plywood
Finish	Textured black polyurethane paint
Casters	4 x Three Inch.
Handles	2 x Steel
Grill	Perforated steel
Mounting Method	Integral 1 3/8" (35 mm) Pole Mount Receptacle,

## Dimensions and Weight

Dimensions	in	20.2" L x 25.3" W x 24.1" H
	mm	513 mm L x 643 mm W x 612 mm H
Weight	lbs	90.5
	kg	41.1

Specifications are subject to change without notice.

Samson Technologies Corp.  
45 Gilpin Avenue  
Hauppauge, New York 11788-8816  
Phone: 1-800-3-SAMSON (1-800-372-6766)  
Fax: 631-784-2201  
[samsontech.com](http://samsontech.com)