

AH210

ALL-IN-ONE AUDIO SOLUTION

USER MANUAL

www.laney.co.uk

 British Engineering from the
Black Country United Kingdom



Welcome

Dear Player,

Thank you very much for purchasing your new Laney product and becoming part of the worldwide Laney family. Each and every Laney unit is designed and built with the utmost attention to care and detail, so I trust yours will give you many years of enjoyment.

Laney products have a heritage which stretches back to 1967 when I first began building valve amplifiers in my parent's garage.

Since then we have moved on from strength to strength developing an extensive range of guitar, bass, public address, multi instrument and keyboard amplification products along with a list of Laney endorsees that includes some of the world's most famous and respected musicians.

At the same time we believe we have not lost sight of the reason Laney was founded in the first place - a dedication to building great sounding amplification for working musicians.

Warm Regards,

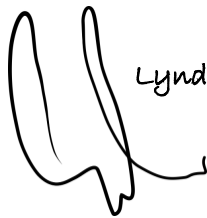

Lyndon Laney Chairman & Founder



Important Safety Instructions

WARNING: When using electrical products, basic cautions should always be followed, including the following:

1. Read these instructions.
2. Keep these instructions safe.
3. Heed all warnings.
4. Follow all instructions.
5. Do not use this apparatus near water.
6. Clean only with a dry cloth.
7. Do not block any of the ventilation openings. Install in accordance with manufacturer's instructions.
8. Do not install near any heat sources such as radiators, heat registers, stoves or other apparatus (including amplifiers) that produce heat.
9. An apparatus with Class I construction shall be connected to a mains socket outlet with a protective connection. Do not defeat the safety purpose of the polarized or grounding-type plug. A polarized plug has two blades with one wider than the other. A grounding type plug has two blades and a third grounding prong. The wide blade or third prong is provided for your safety. If the provided plug does not fit into your outlet, consult an electrician for replacement of the obsolete outlet.
10. Protect the power cord from being walked on or pinched, particularly at plugs, convenience receptacles, and the point they exit from the apparatus.
11. Only use attachments/accessories provided by the manufacturer.
12. Use only with a cart, stand, tripod, bracket, or table specified by the manufacturer, or sold with the apparatus. When a cart is used, use caution when moving the cart/apparatus combination to avoid injury from tip-over.
13. The mains plug or appliance coupler is used as the disconnect device and shall remain readily operable. The user should allow easy access to any mains plug, mains coupler and mains switch used in conjunction with this unit thus making it readily operable. Unplug this apparatus during lightning storms or when unused for long periods of time.
14. Refer all servicing to qualified service personnel. Servicing is required when the apparatus has been damaged in any way, such as when power-supply cord or plug is damaged, liquid has been spilled or objects have fallen into the apparatus, the apparatus has been exposed to rain or moisture, does not operate normally, or has been dropped.
15. Never break off the ground pin. Connect only to a power supply of the type marked on the unit adjacent to the power supply cord.
16. If this product is to be mounted in an equipment rack, rear support should be provided.
17. Note for UK only: If the colours of the wires in the mains lead of this unit do not correspond with the terminals in your plug, proceed as follows:
 - a) The wire that is coloured green and yellow must be connected to the terminal that is marked by the letter E, the earth symbol, coloured green or coloured green and yellow.
 - b) The wire that is coloured blue must be connected to the terminal that is marked with the letter N or the colour black.
 - c) The wire that is coloured brown must be connected to the terminal that is marked with the letter L or the colour red.
18. This electrical apparatus should not be exposed to dripping or splashing and care should be taken not to place objects containing liquids, such as vases, upon the apparatus.
19. Exposure to extremely high noise levels may cause a permanent hearing loss. Individuals vary considerably in susceptibility to noise-induced hearing loss, but nearly everyone will lose some hearing if exposed to sufficiently intense noise for a sufficient time.

The U.S. Government's Occupational Safety and Health Administration (OSHA) has specified the following permissible noise level exposures: According to OSHA, any exposure in excess of the above permissible limits could result in some hearing loss. Earplugs or protectors to the ear canals or over the ears must be worn when operating this amplification system in order to prevent a permanent hearing loss, if exposure is in excess of the limits as set forth above. To ensure against potentially dangerous exposure to high sound pressure levels, it is recommended that all persons exposed to equipment capable of producing high sound pressure levels such as this amplification system be protected by hearing protectors while this unit is in operation.

Duration Per Day in Hours	Sound Level dBA, slow response
8	90
6	92
4	95
3	97
2	100
1 1/2	102
1	105
1/2	110
1/4 or less	115

	<p>Intended to alert the user to the presence of uninsulated 'Dangerous Voltage' within the products enclosure that may be sufficient to constitute a risk of electrical shock to persons.</p> <p>Ce symbole est utilisee pur indiquer a l'utilisateur de ce produit de tension non-isolee dangereuse pouvant etre d'intensite suffisante pour constituer un risque de choc electrique.</p> <p>Este simbolo tiene el proposito de alertar al usuario de la presencia de '(voltaje) peligroso' que no tiene aislamiento dentro de la caja del producto que puede tener una magnitud suficiente como para constituir riesgo de corrientazo.</p> <p>Dieses Symbol soll den Anwender vor unisolierten gefahrlichen Spannungen innerhalb des Gehauses warnen, die von Ausreichender Starke sind, um einen elektrischen Schlag verursachen zu konnen.</p>
	<p>Intended to alert the user of the presence of important operating and maintenance (Servicing) instructions in the literature accompanying the product.</p> <p>Dieses Symbol soll den Anwender vor unisolierten gefahrlichen Spannungen innerhalb des Gehauses warnen, die von Ausreichender Starke sind, um einen elektrischen Schlag verursachen zu konnen.</p> <p>Este simbolo tiene el proposito de la alertar al usuario de la presencis de instrucccones importantes sobre la operacion y mantenimiento en la literatura que viene conel producto.</p> <p>Dieses Symbol soll den Benutzer auf wichtige Instruaktionen in der Bedienungsanleitung aufmerksam machen, die Handhabung und Wartung des Produkts betreffen.</p>
<p>CAUTION:</p> <p>ATTENTION:</p> <p>PRECAUCION:</p> <p>VORSICHT:</p>	<p>Risk of electrical shock - DO NOT OPEN. To reduce the risk of electrical shock, do not remove the cover. No user serviceable parts inside. Refer servicing to qualified personnel.</p> <p>Risques de choc electrique - NE PAS OUVIRIR Afin de reduire le risque de choc electrique, ne pas enlever le couvercle. Il ne se trouve a l'interieur aucune piece pouvant etre reparee par l'utilisateur. Confier l'entretien a un personnel qualifie.</p> <p>Riesgo de corrientazo - no abra Para disminuir el riesgo de corrientazo, no abra la cubierta. No hay piezas adentro que el pueda reparar. Deje todo mantenimiento a los tecnicos calificados.</p> <p>Risiko - Elektrischer Schlag! Nicht offen! Um das Risiko eines elektrischen Schlages zu vermeiden, nicht die Abdeckung entfernen. Es befinden sich keine Teile darin, die vom Anwender repariert werden Konnten. Reparaturen nur von qualifiziertem Fachpersonal durchfuhren lassen.</p>
<p>WARNING:</p> <p>ADVERTISSEMENT:</p> <p>ADVERTENCIA:</p> <p>ACHTUNG:</p>	<p>To prevent electrical shock or fire hazard, do not expose this appliance to rain or moisture. Before using this appliance please read the operating instructions for further warnings.</p> <p>Afin de prevenir les risques de decharge electrique ou de feu, n'exposez pas cet appareil a la pluie ou a l'humidite. Avant d'utiliser cet appareil, lisez les advertissements supplementaires situes dans le guide.</p> <p>Para evitar corrientazos o peligro de incendio, no deja expuesto a la lluvia o humedad este aparato Antes de usar este aparato, lea mas advertcias en la guia de operacion.</p> <p>Um einen elektrischen Schalg oder Feuergefahr zu vermeiden, sollte dieses Gerat nicht dem Regen oder Feuchtigkeit ausgesetzt werden. Vor Inbetriebnahme unbedingt die Bedienungsanleitung lesen.</p>

After unpacking your amplifier check that it is factory fitted with a three pin 'grounded' (or earthed) plug. Before plugging into the power supply ensure you are connecting to a grounded earth outlet.

If you should wish to change the factory fitted plug yourself, ensure that the wiring convention applicable to the country where the amplifier is to be used is strictly conformed to. As an example in the United Kingdom the cable colour code for connections are as follows.

EARTH or GROUND GREEN/YELLOW
NEUTRAL - BLUE
LIVE - BROWN

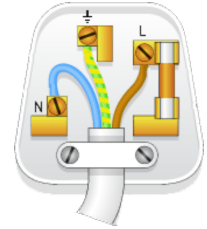

NOTE

This manual has been written for easy access of information. The control panel is graphically illustrated, with each control and feature numbered. For a description of the function of each control feature, simply check the number with the explanations adjacent to each panel. Your AudioHub P.A. has undergone a thorough two stage, pre-delivery inspection, involving actual play testing.

When you first receive your new AudioHub, follow these simple procedures:

(i) Ensure that the amplifier is the correct voltage for the country it is to be used in.

(ii) Connect your instrument with a high quality shielded instrument cable - don't use poor quality cable as it won't do your gear justice.

Please retain your original carton and packaging so in the unlikely event that some time in the future your amplifier should require servicing you will be able to return it to your dealer securely packed.

Care of your Laney amplifier will prolong it's life.....and yours!

Introduction

The Laney Audiohub Venue AH210 is designed to be an all-in-one audio solution for a wide variety of everyday applications – from classroom, dance studio to a business seminar or any kind of musical performance.

The Audiohub Venue gives you all the ease and convenience of everything you need to get the job done with the minimum of fuss.

Its sleek detachable mixer section offers a wide selection of inputs/outputs including a Bluetooth® equipped media player. The accompanying Mic, XLR cable, a pair of speaker leads and power cord supplied, are all housed in a neat clip off compartment. Both enclosures include handles and 35mm pole cups.

The Audiohub Venue – Clarity & Convenience.



This manual contains important information regarding correct and safe operation of your active system. Please read it thoroughly in order to get the best performance and reliability from your new Laney product.

Setting up

Access to the Mixer and accessory box:

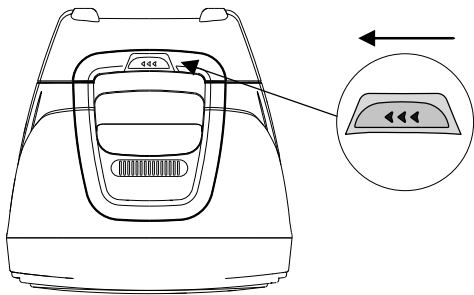

Slide the catch to the left as indicated.

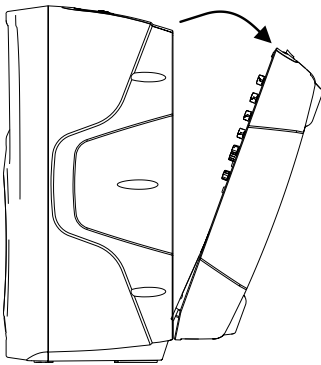

Gently tilt the mixer/accessory box then unhook from the cab.

Power and speaker connections:

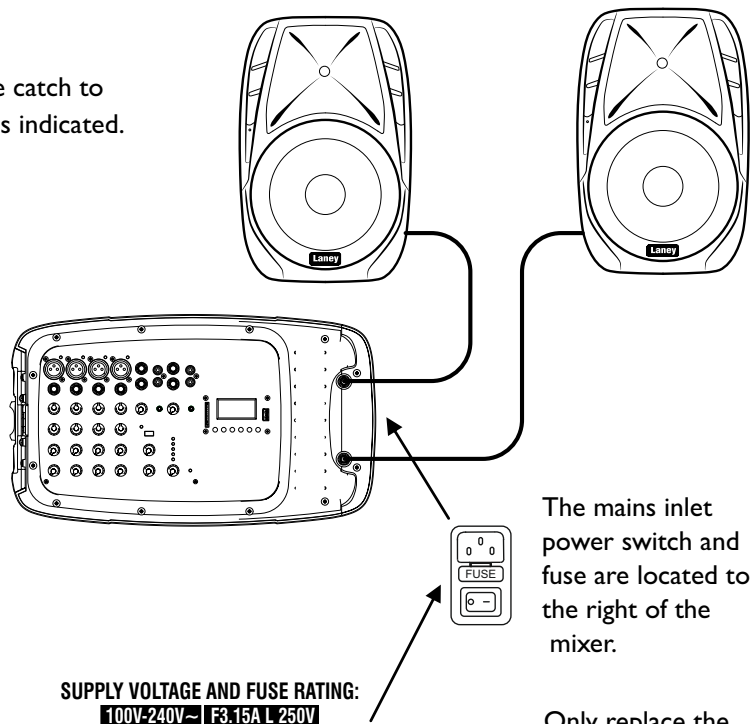

The mains inlet power switch and fuse are located to the right of the mixer.

Only replace the fuse with the type stated!

Always switch off and disconnect the power cord when not in use.

www.Laney.co.uk

Applications

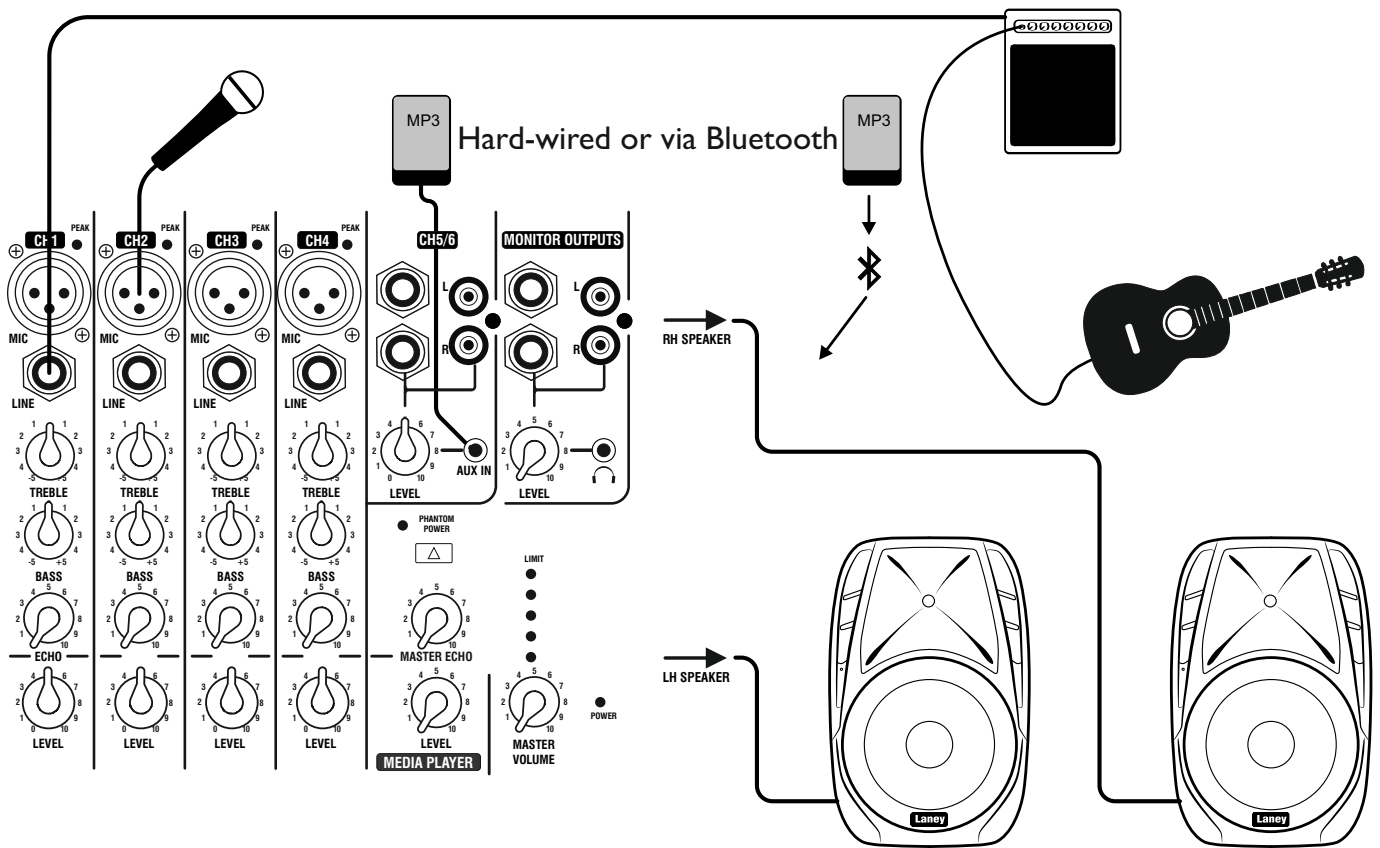

Solo performance.

www.Laney.co.uk

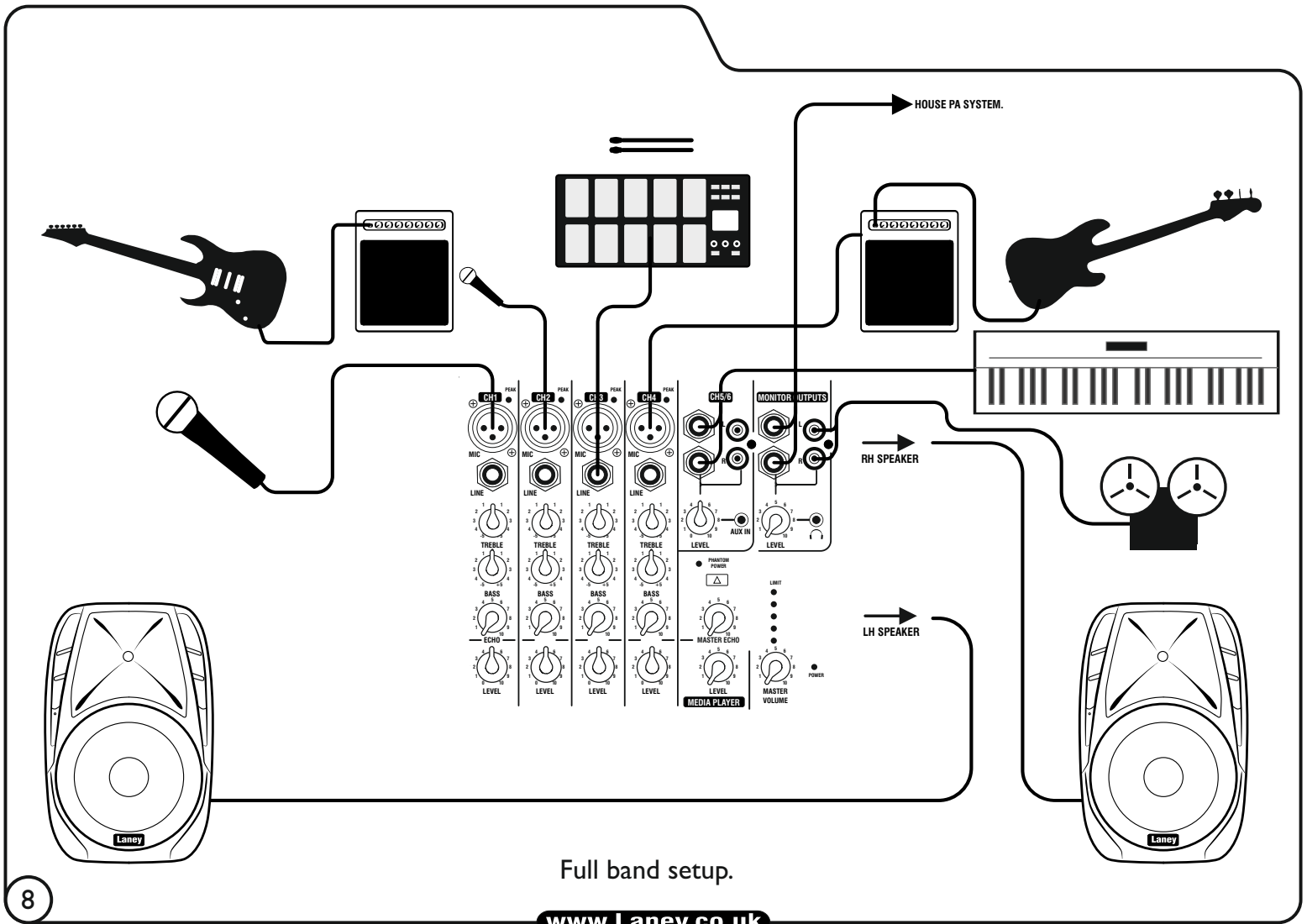

Control Panel

1-4: MONO INPUT CHANNELS.

5. PEAK: Adjust the level controls and signal level from your source(s) so the LED illuminates only briefly on peaks in the music. Using the system with this LED on all or most of the time will result in poor sound quality.

6. MIC INPUT: A balanced XLR input for low level, low impedance devices eg. - mic (200-600ohms) or electro-acoustic guitar.

7. LINE INPUT: an unbalanced input - for higher output line level devices eg. -keyboard, processor, sample/drum machine etc.

Note: Mic and Line inputs can be used simultaneously.

8. EQ: 2 band active EQ for adjusting the signal. Setting both controls to 0 is a good starting point.

9. ECHO: This control determines how much (if any) of each channel is sent through the onboard echo FX processor - also see (15)

10. LEVEL: Controls the channel level to the master volume - also see (22).

11. CH 5/6: A multi input line level Stereo channel. Choose from 2x 6.35mm jack, RCA or 3.5mm jack. Any combination, or all can be used together.

12. LEVEL: Control the level of signal from channel 5/6 to the Master Volume.

13. AUX IN: Connect an audio feed from an external MP3 player or mobile phone here. Please use a stereo cable for this. The level can be adjusted using Level control(12).

14. PHANTOM POWER: Turns on Phantom Power to all Mic channels should it be needed, eg. condenser mic's.

15. MASTER ECHO: Control the overall level of the feed from the onboard FX processor. If you want to apply Echo to a mono channel, first set the Master control to 5. Slowly increase the Input Echo send control until the desired amount of echo is achieved. The Master control can then be used to control the overall Echo level.

16. MEDIA PLAYER LEVEL: Controls the overall level of music from the onboard media player. See media player controls 23-30.

17. MONITOR OUTPUTS: A convenient way of connecting your AH210 AudioHub to another device such as an additional amp/speaker setup, recording device or possibly both at the same time via the jack and RCA connectors or 6.35mm jacks. You can also monitor this signal feed via headphones.

18. MONITOR LEVEL: Control the MONITOR OUTPUT and headphone level.

19. HEADPHONES: Connect your headphones here. The volume can be adjusted using level control (18).

20. OUTPUT LEVEL METER: Use this to give an idea of the overall output level of your AH210 AudioHub system. If the LIMIT led is constantly on, reduce the MASTER VOLUME (22)

21. POWER LED: This will illuminate when the unit is powered up.

22. MASTER VOLUME: Controls the overall level of your AH210 AudioHub system.

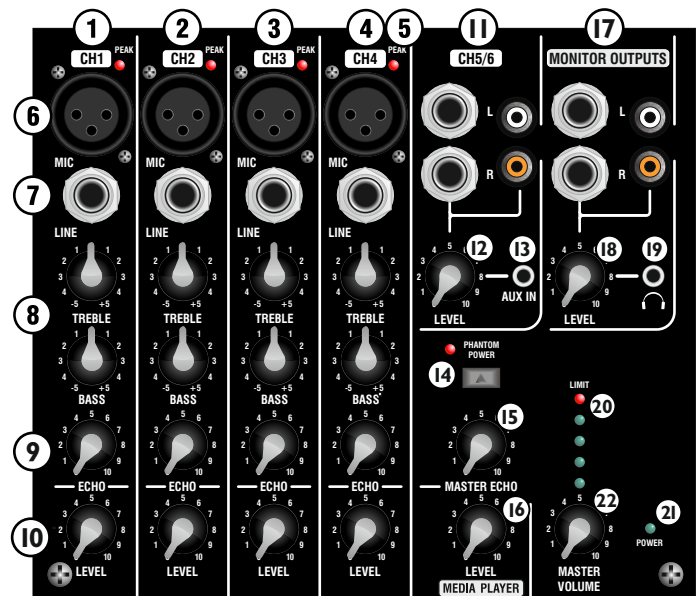

Media Player

Use the onboard player for playing back MP3/WMA encoded audio tracks from SD card/USB or Bluetooth® device.

- 1. SD CARD SLOT:** Insert your standard SD card here.
(Automatically detected on insertion, or if removed & reinserted uses smart technology to resume play from the previous point).
- 2. MEMORY STICK SLOT:** Connect your USB memory stick here.
(Automatically detected on insertion, or if removed & reinserted uses smart technology to resume play from the previous point).
NOTE. The USB socket is for the playback of recorded tracks only, not for charging a USB device.
- 3. MODE:** Select the input source - SD card USB or Bluetooth® and power OFF the player.
(If multiple media sources are available).
- 4. PLAY/PAUSE:** Use this control to play or pause your music.
- 5. STOP:** Click this to stop playback.
- 6. LOOP:** Gives 5 different options when playing tracks from an SD card or a USB Stick :
 - 1 - Single track repeated
 - N** - Single track & stop
 - R** - All tracks played randomly
 - I** - Plays a 10 sec intro of each track in strictly Alphanumeric order
 - A** - All tracks played in strictly Alphanumeric order

7. PREVIOUS: Press to skip to the preceding track.

8. NEXT: Press to skip to the next track.

9. DISPLAY SCREEN: Display track information.

Press the **MODE** button to turn on the media player. With nothing connected, the **Previous & Next** buttons step through 'music' (with spinning record display), Bluetooth (with pulsing Bluetooth logo) and USB (dancing computer). See photos 1, 2 and 3.

Insert a USB Stick/SD Card loaded with music tracks and the media player will recognise it and play the tracks in strictly Alphanumeric order including sub folders as they are discovered. See Page 9 for media player Level/Volume controls.

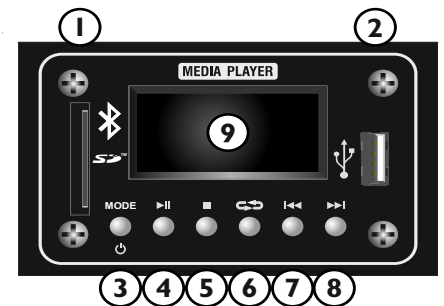

THE DISPLAY

- 10. Shows the option selected via the LOOP button, either 1, N, R, I or A
- 11. Number of the track playing on the top line, number of tracks on the device on the bottom line.
- 12. Normal EQ setting, (this is factory configured).
- 13. Play or Pause symbol.
- 14. Device symbol dependant on what is playing.
- 15. Time into the track/length of the track.
- 16. Track number, name & file type.
- 17. EQ Bargraph display

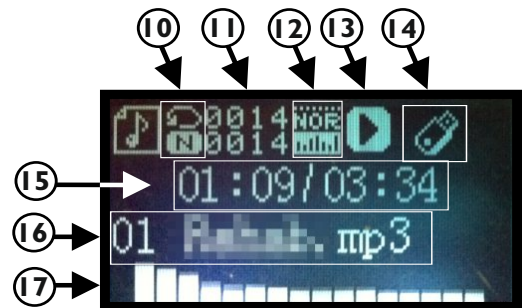

CONNECT TO AN EXTERNAL BLUETOOTH® DEVICE:

- a. Select Bluetooth via the MODE button
- b. On your Bluetooth® capable device, make sure Bluetooth® is enabled. Scan down the list of available devices - search for: **Laney Audiohub** and select. (No password required).
- c. Your AudioHub is now connected to your bluetooth device which can be controlled using the **PLAY/PAUSE, PREVIOUS & NEXT BUTTONS**

Only one Audiohub can be paired to your Bluetooth® capable device at once, so remember to de-select & forget a device if you plan to use a different Audiohub device next time.

Block Diagram

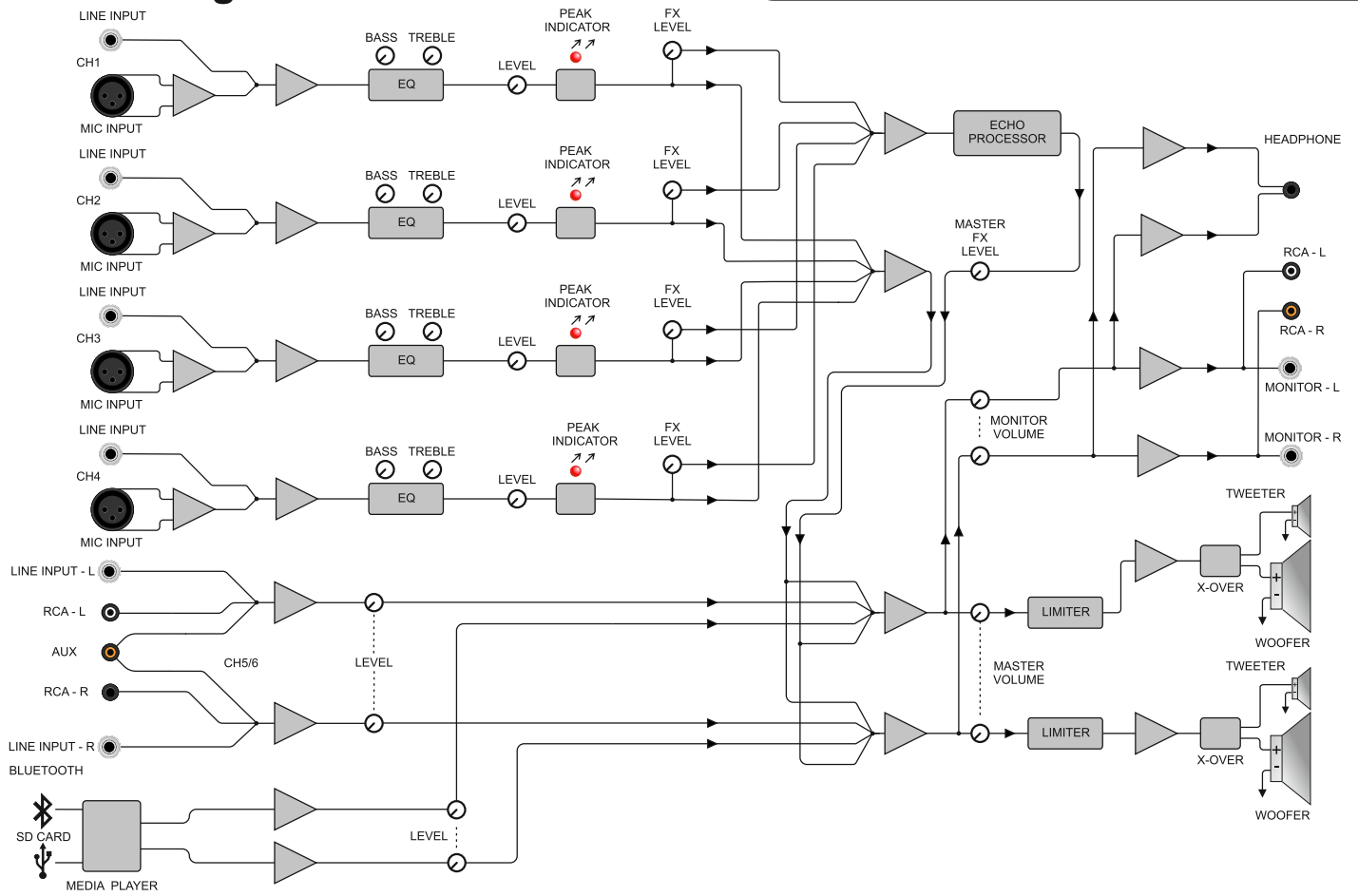

Dimensions and mounting

(Stand not included)

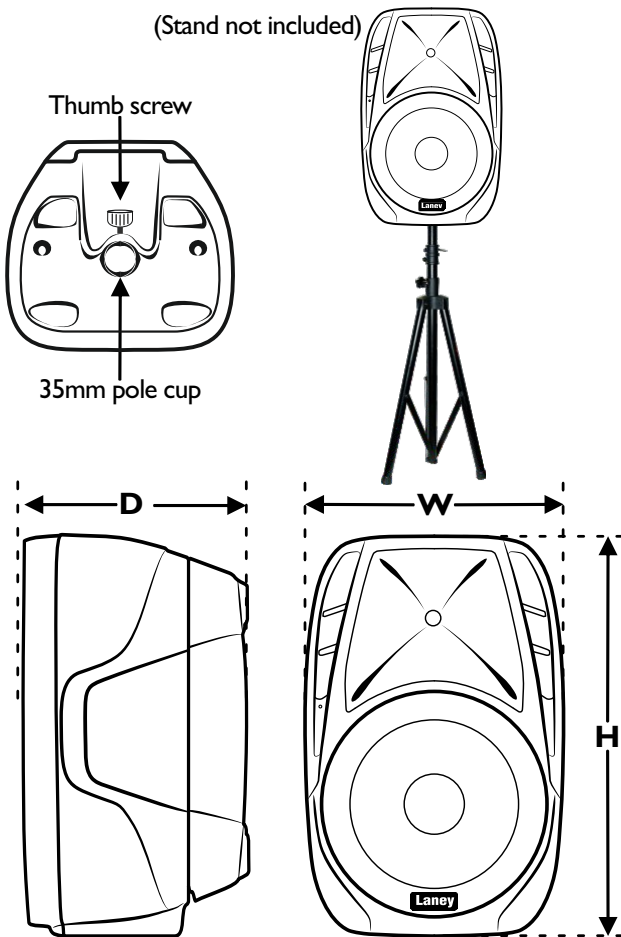

All cabinets should be balanced and steady.

Don't over-extend poles/tripods; ensure at least 4 x the pole diameter is still inside the outer pole.

Make sure the legs have a good splay on tripods, but do not obstruct doorways or other access-ways.

If a pole mount is used, make sure that the thumb screw on the cabinet is tight.

Keep lights away from speakers; heat can cause fires/speaker damage.

Don't run cables across access-ways; if you have to, run them above doors or use approved cable covers.

Be aware of total power usage. Overloading a mains socket is potentially dangerous, and likely to cause a power out during use.

Keep lighting cables away from ALL sound cables including mains, use separate circuit for lights if possible.

Keep power and signal cables apart.

MODEL	DEPTH (D)	WIDTH (W)	HEIGHT (H)	WEIGHT (KG)
Unboxed	312	315	490	9.5+10.5
Boxed	365	635	555	22

(All dimensions in mm's)

Specifications and features

AH210

Amplifier Power:	400W total (2*200W)
Frequency range:	20Hz-20kHz
Woofer:	10" (per cabinet)
Tweeter:	1" Compression Driver (per cabinet)
Power Consumption:	300Watts (Maximum)
Operating Voltage Range:	100V-240V~
Fuse:	F3.15A L 250V
Mic Input:	Balanced 2K2 Ohm
Mic Sensitivity:	-33dBu (15mV) (nominal)
Line Input:	Unbalanced 10K Ohm
Line Sensitivity:	0dBu (0.75V) (nominal)

I/O Connector wiring:

6.35mm Unbalanced Jack

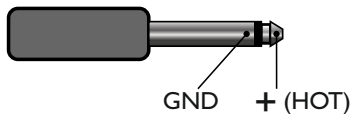

3.5mm Stereo Jack

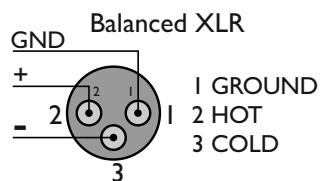
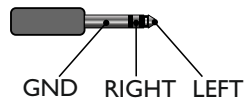

4 Mono inputs -

Balanced XLR Mic (With global switchable Phantom power)
 Unbalanced Line Input 6.35mm Jack,
 Active EQ - Treble and Bass,
 Echo level send control,
 Channel level control,
 Peak led.

Multi input stereo channel -

2 unbalanced Line Level 6.35mm Jack,
 1 Stereo 3.5mm minijack,
 Left and Right RCA connectors,
 Level control.

Monitor Outputs -

Left & Right 6.35mm Jack,
 Left & Right RCA connectors,
 3.5 mm Headphone output,
 Level control.

Master Outputs -

Left & Right 6.35mm jack,
 Master Volume,
 LED level meter,
 Master Echo level.

Media Player -

Bluetooth A2DP,
 SD Card,
 USB Host,
 Level control.

FCC Compliancy Statement

FC This device complies with Part 15 of the FCC rules. Operation is subject to the following two conditions:

- 1) This device may not cause harmful interference
- 2) This device must accept any interference received, that may cause undesired operation.

Warning: Changes or modification to the equipment not approved by Laney can void the user's authority to use the equipment.

Note: This equipment has been tested and found to comply with the limits for Class B digital device, pursuant to Part 15 of the FCC Rules. These limits are designed to provide reasonable protection against harmful interference in a residential installation. This equipment generates, uses and can radiate radio frequency energy and if not installed and used in accordance with the instructions, may cause harmful interference to radio communications. However, there is no guarantee that interference will not occur in a particular installation. If this equipment does cause harmful interference to radio or television reception, which can be determined by turning the equipment off and on, the user is encouraged to try and correct the interference by one or more of the following measures.

- Reorient or relocate the receiving antenna.
- Increase the separation between the equipment and receiver.
- Connect the equipment into an outlet on a circuit different from that to which the receiver is connected.
- Consult the dealer or an experienced radio/TV technician for help

CE This product conforms to the requirements of the following European Regulations, Directives & Rules: CE Mark (93/68/EEC), Low Voltage 2006/95/EC, EMC (2004/108/EEC), RoHS (EU2002/95/EC), WEEE (EU2002/96/EC)



In order to reduce environmental damage, at the end of its useful life, this product must not be disposed of along with normal household waste to landfill sites. It must be taken to an approved recycling centre according to the recommendations of the WEEE (Waste Electrical and Electronic Equipment) directive applicable in your country.

In the interest of continued development, Laney reserves the right to amend product specification without prior notification.

Bluetooth® and the Bluetooth logo are registered trademarks of Bluetooth SIG and any use by Plantronics is under license.



Model number:

Serial number:

Place of purchase:

Date of purchase:

Please complete for future reference



www.laney.co.uk