



Loudspeaker System



Flush Mount



Surface Mount

HT-3 Owner's Manual



Manufactured under license from Lucasfilm Ltd.. Additionally licensed under the following patent U. S. number 5,043,970. Foreign patents pending. Lucasfilm THX Audio and Home THX Cinema are trademarks of Lucasfilm Ltd.. Lucasfilm is a trademark of lucasfilm Ltd..

WARNING - TO REDUCE RISK OF FIRE OR ELECTRICAL SHOCK, DO NOT EXPOSE THIS EQUIPMENT TO RAIN OR MOISTURE.

NO USER-SERVICEABLE PARTS INSIDE. REFER SERVICING TO QUALIFIED PERSONNEL.

To prevent the risk of electric shock, do not remove cover or back. No user serviceable parts inside.

IMPORTANT SAFETY INSTRUCTIONS!

PLEASE READ THEM BEFORE OPERATING THIS EQUIPMENT.

1. Read these instructions.
2. Keep these instructions.
3. Heed all warnings.
4. Follow all instructions.
5. Do not use this apparatus near water.
6. Clean only with a dry cloth.
7. Install in accordance with the manufacturer's instructions.
8. This apparatus is capable of producing high sound pressure levels. Continued exposure to high sound pressure levels can cause permanent hearing impairment or loss. User caution is advised and ear protection is recommended when playing at high volumes.
9. Do not install near any heat sources such as radiators, heat registers, stoves, or other apparatus (including amplifiers) that produce heat.
10. Only use attachments/accessories specified by the manufacturer.
11. Use only with the cart, stand, tripod, bracket, or table specified by the manufacturer, or sold with the apparatus. When a cart is used, use caution when moving the cart/apparatus combination to avoid injury from tip-over.
12. Refer all servicing to qualified service personnel. Servicing is required when the apparatus has been damaged in any way, liquid has been spilled or objects have fallen into the apparatus, the apparatus has been exposed to rain or moisture, does not operate normally, or has been dropped.
13. Do not expose this equipment to dripping or splashing and ensure that no objects filled with liquids, such as vases, are placed on the equipment.



Thank You

Your decision to own this McIntosh HT-3 Loudspeaker System ranks you at the very top among discriminating music listeners. You now have “The Best.” The McIntosh dedication to “Quality,” is assurance that you will receive many years of musical enjoyment from this unit.

Please take a short time to read the information in this manual. We want you to be as familiar as possible with all the features and functions of your new McIntosh.

Please Take A Moment

The serial number, purchase date and McIntosh Dealer name are important to you for possible insurance claim or future service. The spaces below have been provided for you to record that information:

Serial Number: _____

Purchase Date: _____

Dealer Name: _____

Technical Assistance

If at any time you have questions about your McIntosh product, contact your McIntosh Dealer who is familiar with your McIntosh equipment and any other brands that may be part of your system. If you or your Dealer wish additional help concerning a suspected problem, you can receive technical assistance for all McIntosh products at:

McIntosh Laboratory, Inc.
2 Chambers Street
Binghamton, New York 13903
Phone: 607-723-1545
Fax: 607-723-3636

Customer Service

If it is determined that your McIntosh product is in need of repair, you can return it to your Dealer. You can also return it to the McIntosh Laboratory Service Department. For assistance on factory repair return procedure, contact the McIntosh Service Department at:

McIntosh Laboratory, Inc.
2 Chambers Street
Binghamton, New York 13903
Phone: 607-723-3515
Fax: 607-723-1917

Table of Contents

Safety Instructions	2
Thank You and Please Take a Moment	3
Technical Assistance and Customer Service	3
Table of Contents and Important Information	3
Introduction	4
Performance Features	5
Dimensions	6
Installation using the Flush Mount HT-3	10
Installation using the Surface Mount HT-3	12
How to Connect	14
Specifications	22
Packing Instruction	23

Important Information

- Loudspeaker Cables of adequate size are important to ensure that there will be no significant power loss or heating. Cable size is specified in Gauge numbers or AWG (American Wire Gauge). The smaller the Gauge number, the larger the wire size:
If the Loudspeaker Cables are 25 feet (7.62m) or less, use at least 16 Gauge (AWG) wire size or larger.
If the Loudspeaker Cables are 50 feet (38.1m) or less, use at least 14 Gauge (AWG) wire size or larger.
If the Loudspeaker Cables are 100 feet (76.2m) or less, use at least 12 Gauge (AWG) wire size or larger.
The Loudspeaker Connection Terminals can accept up to 12 Gauge (AWG) wire.*
- For additional connection information, refer to the owner's manual(s) for any component(s) connected to the HT-3 Loudspeaker.*

Introduction

The McIntosh HT-3 Loudspeaker System is designed for Home Theater and Music Reproduction. It is a two-way system with two 5-inch low frequency and two 1-inch dome tweeters. The HT-3 is designed to work as Surround Loudspeaker in a Home Theater System.

The HT-3 Loudspeaker performance is equivalent to the quality of McIntosh's legendary line of Amplifiers, Preamplifiers, Signal Processors and Signal Sources, without imparting distortion or coloration of its own. It also complements the capabilities and the remarkably low distortion of McIntosh Power Amplifiers.

To reproduce sound accurately, all forms of distortion, both harmonic and intermodulation, must be kept to a minimum. This has been the result of the design of the new McIntosh HT-3 Loudspeaker System. Each loudspeaker element and crossover component has been carefully designed for durability, efficiency, and above all, low distortion. The McIntosh HT-3 Loudspeaker System will function as an excellent Home Theater Loudspeaker Surround Loudspeaker.

Performance Features

- **High Performance Drivers**

Each HT-3 enclosure contains two 5-inch Polypropylene Low Frequency Drivers and two 1-inch Aluminum Dome High Frequency Drivers arranged in an Antiphase Dipole, Mirror Image configuration.

- **Special Crossover**

At frequencies below 350Hz both Low Frequency Drivers operate in-phase; above 350Hz both the Low Frequency Drivers and Tweeters operate out-of-phase thus providing the desired diffused surround effect. Both the Low and High Frequency Drivers are crossed over at a 12dB per octave rate.

- **High Efficiency**

The Loudspeaker Elements used in the HT-3 Loudspeaker System have also been designed for high efficiency. As a result any McIntosh Power Amplifier, even our smallest, will provide satisfying room filling sound, yet they can be used with amplifiers up to 200 watts.

- **Minimum Visual Impact**

The HT-3s offer a unique solution to the problem of integrating superb surround sound into a room without drawing attention to the Loudspeakers. The removable metal grilles can be custom painted or wall papered to perfectly match your decor.

- **Sealed Enclosures**

A sealed solidly braced enclosure is used in both the Surface Mount and Flush Mount version for superior sound and freedom from bleeding into adjacent rooms.

- **Gold Plated Input Connectors**

The HT-3 input connectors are gold plated for superior corrosion resistance and high electrical conductivity.

- **THX® Approved**

The HT-3 Surround Loudspeaker System meets and exceeds the performance requirements of the THX Standard for the best possible reproduction of a film sound track that was originally created for use in a movie theater.

HT-3 Dimensions

The following dimensions can assist in determining the best location for your HT-3 Loudspeaker System.

HT-3 Surface Mount without Grille

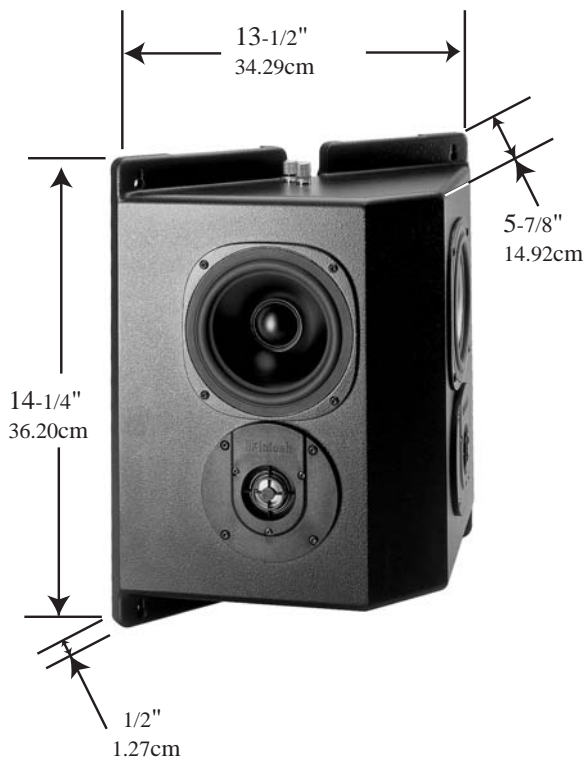

HT-3 Surface Mount with Grille

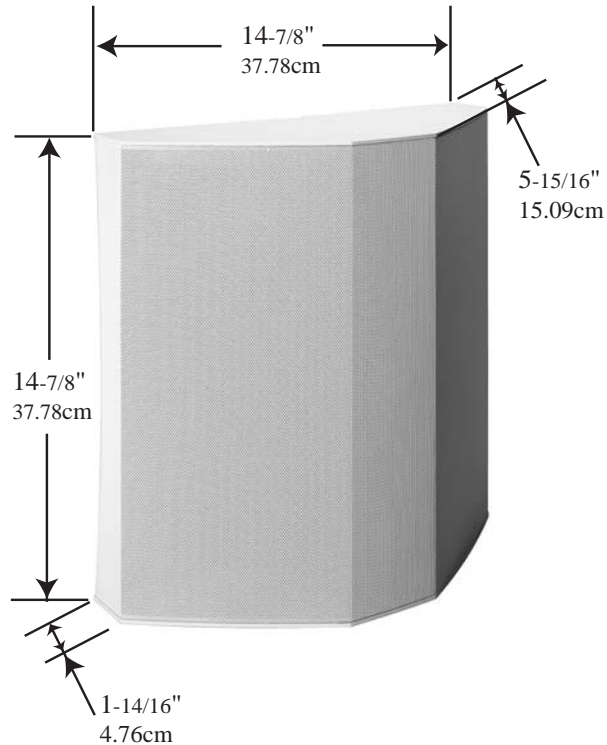

HT-3 Flush Mount without Grille

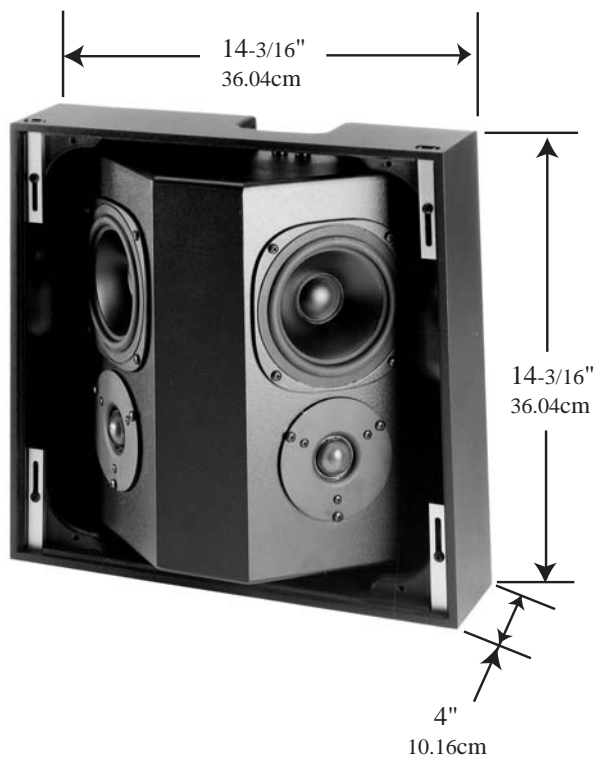

HT-3 Flush Mount with Grille

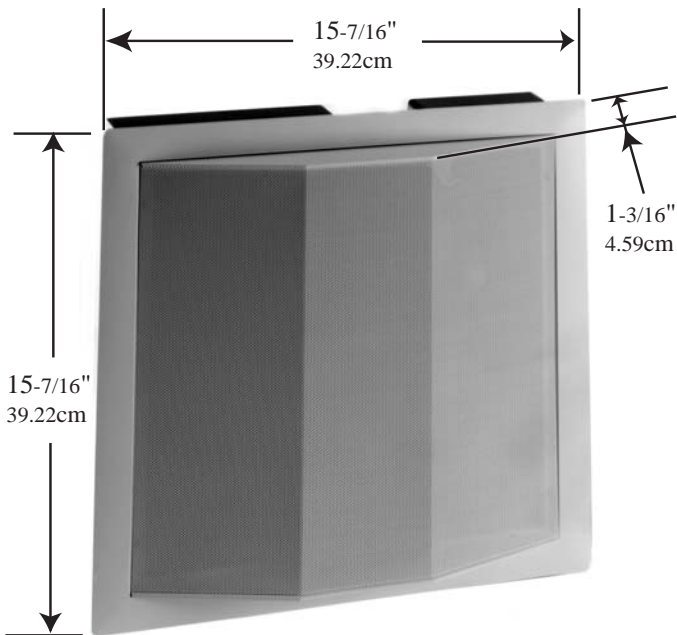

Introduction

The McIntosh HT-3 Surround Loudspeaker is specifically optimized for sound applications. The Surround Loudspeakers are intentionally designed to create a very diffuse sound field. The HT-3 uses a dipolar radiation pattern to achieve this performance. A dipole loudspeaker radiates sound both forward and backward, with acoustic nulls located at the vertical center of the enclosure. If a dipole loudspeaker is placed such that the listeners are seated within the nulls, they will hear surround sound only after it has been randomly reflected off of the walls of the room. The listener will perceive no specific direction for surround sound. Refer to figure 1.

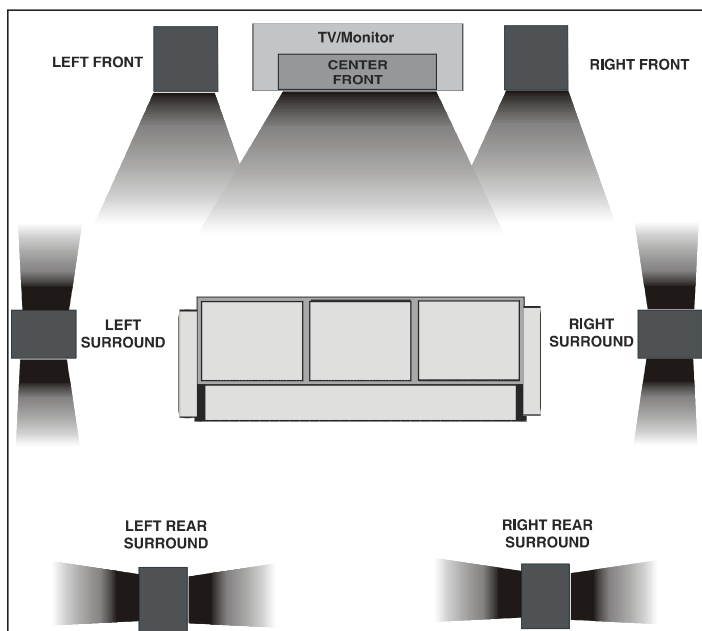

Figure 1

The HT-3 achieves this dipolar radiation via independent forward and rearward firing 2-way systems connected in antiphase to assure a cancellation null at right angles. Complete mirror symmetry of forward and rearward firing faces of the HT-3 assure a deep broadband null of all frequencies for any position on the dividing plane of the system. This includes upward and downward elevation angles and allows the HT-3 to be mounted in a variety of heights on the side wall (or even on the ceiling), as long as the listener is on the dividing plane between left and right halves of the HT-3.

Varying the Sound Field

Some listeners will want a less diffuse and more directional effect from their surround loudspeakers. To them, sound panning off screen, such as jets flying overhead, are more important than the creation of a diffuse sound field. This is perfectly acceptable and can be achieved by mount-

ing the HT-3 Loudspeakers so that the listener is not on the null of the system but perhaps 20 degrees forward or backward of the null. The selected volume level of the surround speakers will also play a major role in determining whether the surround effects are obvious or subtle.

In very large installations, more than one pair of HT-3 Surround Loudspeakers can be used. This would apply in home installations with four or more rows of theater style seating. For such installations install a pair of HT-3 systems in the normal way adjacent to the first seating row. For every third or fourth row behind, install an additional pair. Each additional pair of surround Loudspeakers should have its polarity reversed relative to the pair immediately in front. Polarities from the front would be normal, reversed, normal, reversed, etc. Change the polarities by alternating the connections on each pair of Loudspeakers, in order, behind the original pair. Refer to figure 2.

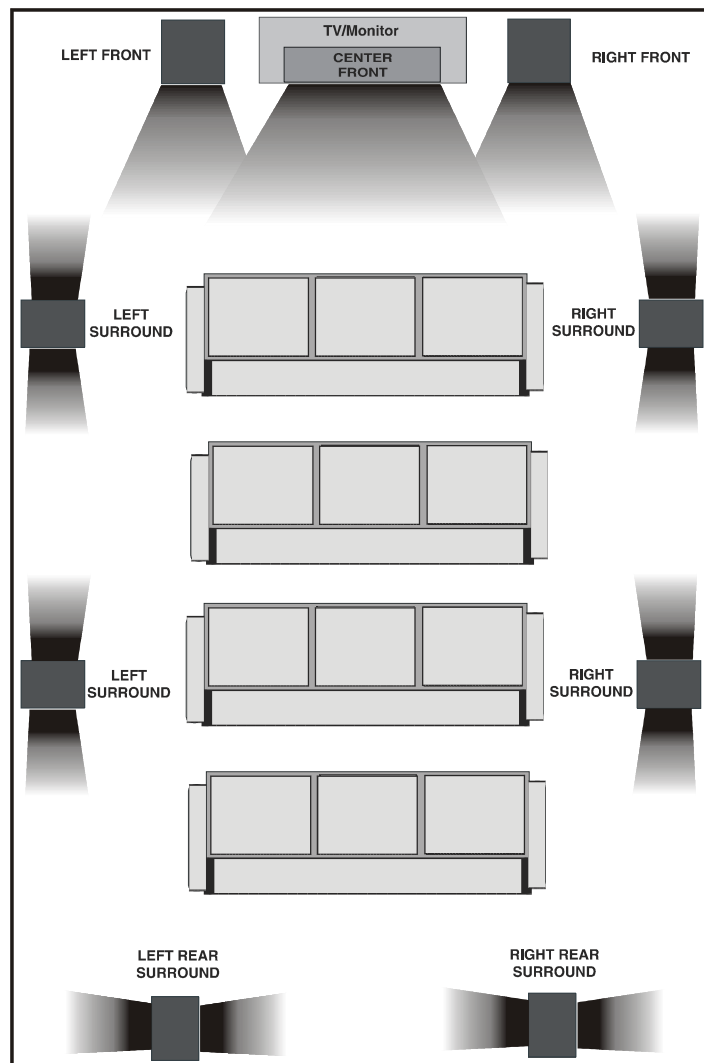

Figure 2

Installation

The HT-3 Surround Loudspeaker System may be installed with one person, however two persons will add to the safe handling during installation. Follow the instructions below for unpacking and assembly. It is recommended that the Professionals at your McIntosh Dealer, who are skilled in all aspects of installation and operation, install the HT-3 Loudspeaker System and any associated audio equipment. The HT-3 Surround Loudspeaker System is a mirror-image, dipole design with the pair of 2 way systems connected out of phase with each other. The pair facing forward toward the viewing screen must be in phase with the front Loudspeakers. To insure correct phasing, the loudspeakers are marked as Left and Right, along with a directional arrow which must be pointing toward the screen and the front loudspeakers.

HT-3 Surface Mount

1. Remove the front grille from the HT-3 by gently pulling it forward. Refer to figure 3.

2. Position the HT-3 on the wall where you wish to mount it. Using the Loudspeaker assembly as a template,

mark on the wall the locations for the four mounting screws.

3. Install using four suitable wall mounting fasteners and insert the screws partially so they extend out far enough to clear the thickness of the HT-3 back panel.

Note: The fasteners must have a total of 20 pounds or more of load capacity.

4. Position the HT-3 over the screws and slide it down so the screws fit in the mounting slots. Tighten the screws.

5. Replace the HT-3 grille by gently pressing it inward where the foam gaskets will hold it in place. Follow the same procedure for both the Left and Right HT-3 systems.

Note: If the HT-3 is ceiling mounted, additional fasteners are needed to secure the grille to the Loudspeaker.

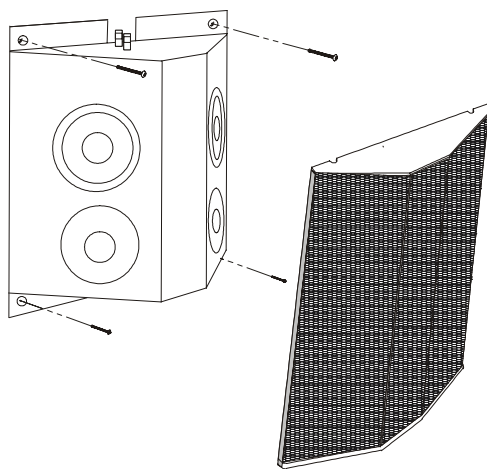

Figure 3

HT-3 Flush Mount

1. Determine the location where you wish the HT-3 Loudspeakers to be installed in the wall. Refer to figure 4.
2. Cut a 14-1/4 inch square hole centered in the desired position.

The location should be centered between the wall studs since the HT-3 will take most of the space, with just a small clearance on each side.

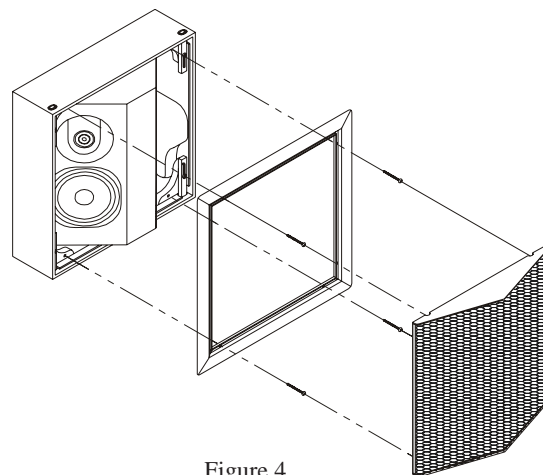

Figure 4

Note: There must be no obstructions within 1 inch of the cutout on the top and bottom. This is to provide clearance for the slide fasteners to fit behind the wall panel. The area behind the HT-3 must be free of any wires, cables or other obstructions since the speaker depth is 3-1/2 inches, and may fill the entire space between the walls.

3. Remove the front trim frame and grille.
4. Proceed to page 8 for connection information and then perform step 5 below.
5. Carefully slide the HT-3 into the wall cutout.

Note: If the wall studs are 2 x 6, be careful to hold the speaker in place so it does not fall behind the wall prior to securing the trim frame.

6. Loosen the screws on the four slide fasteners. Slide the fasteners up and down so they fit behind the wall to hold the HT-3 in place and then tighten the screws.
7. Place the trim frame in position over the HT-3 and secure it to the loudspeaker system using the supplied screws. Use the mounting holes at the top and bottom edges of the frame

Note: The holes on the sides of the frame are not used.

8. Carefully press the grille into the trim frame, where the foam gasket will hold in position.

How to Prepare Hookup Cables

The McIntosh HT-3 Loudspeaker System utilizes binding posts for speaker wire connections. Prepare the Loudspeaker Hookup Cables that attach to the Power Amplifier Output Terminals:

Bare wire cable ends:

Carefully remove sufficient insulation from the cable ends, refer to figures 5, 6 & 7. If the cable is stranded, carefully twist the strands together as tightly as possible.

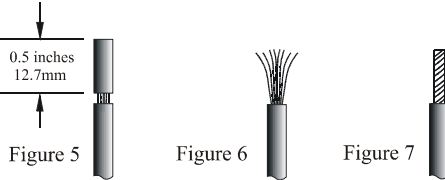

Note: If desired, the twisted ends can be tinned with solder to keep the strands together and/or attach a spade lug.

Spade lug or prepared wire connection:

Insert the spade lug connector or prepared section of the cable end into the terminal side access hole, and tighten the terminal cap until the cable is firmly clamped into the terminal so the wires cannot slip out. Refer to figures 8, 9 & 10.

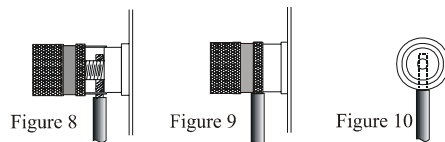

Insert the spade lug connector or prepared section of the cable end into the terminal side access hole, and tighten the terminal cap until the cable is firmly clamped into the terminal so the wires cannot slip out. Refer to figures 8, 9 & 10.

How to Connect

1. Connect a Loudspeaker cable from the Negative (-) Binding Post of the Amplifier to the HT-3 Binding Post with the black strip.
2. Connect a Loudspeaker cable from the Positive (+) Binding Post of the Amplifier to the HT-3 Binding Post with the red strip.
3. Tighten all of the Loudspeaker and Amplifier Binding Posts.
4. Proceed to page 7 to complete the installation.

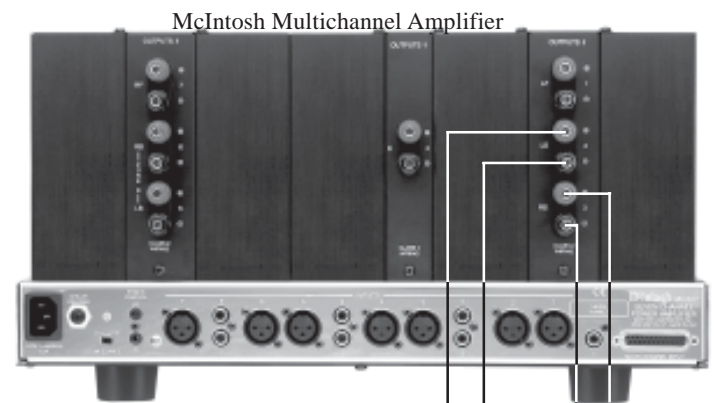

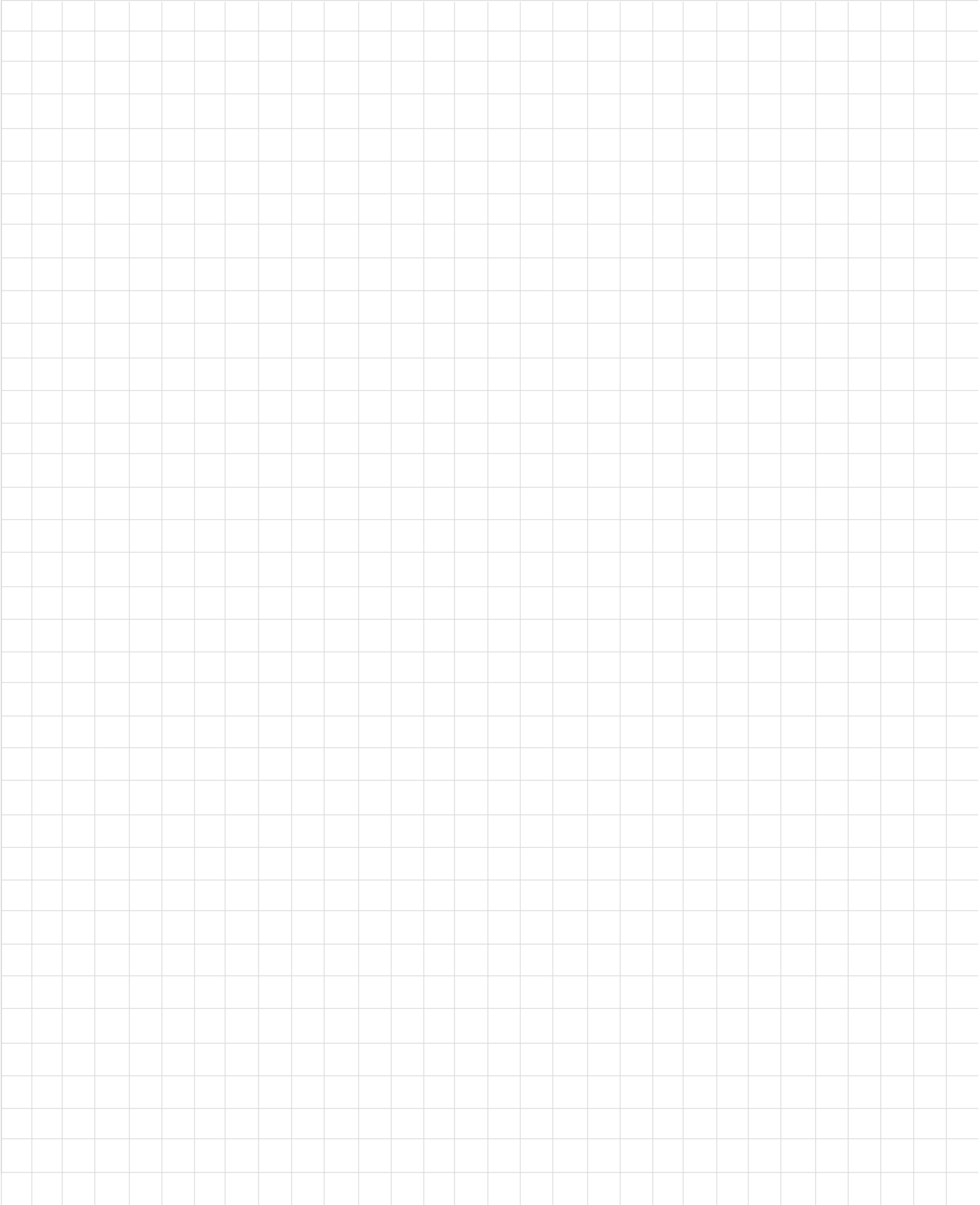

Specifications

System Driver Complement

Two 5-inch Low Frequency Drivers
Two 1-inch Dome Tweeters

Impedance

4 ohms Nominal

Frequency Response

85Hz - 12kHz

Sensitivity

88dB (2.8V/1m)

Crossover Frequency

1,500Hz

Power Handling

200 Watts Maximum

Overall Dimensions

HT-3 Surface Mount with grille:
14-7/8 inches (37.78cm) Height, 14-7/8 inches (37.78cm)
Width, 5-15/16 inches (15.09cm) Depth

HT-3 Flush Mount with grille and trim frame:
15-7/16 inches (39.22cm) Height, 15-7/16 inches
(39.22cm) Width, 5-3/16 inches (14.75cm) Depth

Finish

Grilles and Trim Frame are painted white

Weight (each)

HT-3 Surface Mount:
17.6 pounds (7.98kg) net, 23 pounds (10.43kg) in
shipping carton

HT-3 Flush Mount:
19.5 pounds (8.85kg) net, 25 pounds (11.34kg) in
shipping carton

Packing Instructions

In the event it is necessary to repack the equipment for shipment, the equipment must be packed exactly as received. Failure to do so will result in shipping damage.

Use the original shipping carton and interior parts only if they are in good serviceable condition. If a shipping carton or any of the interior part(s) are needed, please call or write Customer Service Department of McIntosh Laboratory.

<u>Quantity</u>	<u>Part Number</u>	<u>Description</u>
1	034257	Shipping carton
1	034258	Foam end cap top
1	034259	Foam center cap bottom
4ft	033093	Air cap (24 inches wide)



McIntosh Laboratory, Inc.
2 Chambers Street
Binghamton, NY 13903

The continuous improvement of its products is the policy of McIntosh Laboratory Incorporated who reserve the right to improve design without notice.

Printed in the U.S.A.

McIntosh Part No. 04092000