

Audionet

AMP V

Multichannel Power Amplifier

User's Manual

Content

1	Preface	4
1.1	Included	5
1.2	Transportation.....	5
2	Overview control elements.....	6
2.1	Front panel.....	6
3	Overview connections.....	7
3.1	Back panel	7
4	Installation and power supply	8
4.1	Placement	8
4.2	Mains connection.....	8
4.3	Orientation of mains plug.....	9
5	Inputs and outputs.....	10
5.1	Line inputs	10
5.2	Speaker terminals	11
6	Operating.....	11
6.1	Switching on/off.....	11
6.2	Mains phase detection	12
6.3	Audionet Link.....	12
7	Protection system.....	13
8	Security notes	15
9	Technical data	16

1 Preface

The Audionet Team congratulates you to your purchase of this unit.

AMP V is Audionet's latest 5-channel power amplifier. For everyone, who needs more power, but is not willing to provide the space for gigantic amplifiers occupying cubicmeters of your listening room. AMP V is our power amplifier for multi-channel setups, and in conjunction with our high-class home theater pre amplifier MAP 1, it is more space-saving as many of the surround receiver flagships. And even better: In no way more expensive!

AMP V accomplishes the feat to combine outstanding performance and matchless sound character with utmost compactly dimensions. Its five channels render recent 5.1 home cinemas possible. With these features, the AMP V is predestined for home theater solutions in particular suitable for your living space and primarily convincing in sound.

Whether it is Mozart or King Kong, AMP V masters all its tasks with dedication and captivates its audience with an authenticity rarely to be experienced. Its sound is fast, vigorous and thoroughly honest, but simultaneously full of concinnity, grace and accuracy. Paired with its contagious delight of performance, an amazingly realistic sound experience arises.

AMP V represents the latest state of Audionet's award-winning amplifier technology and audiophile passion: Engineered and produced in Bochum, Germany.

Like in all our mono and stereo power amplifiers, we consequently realized Audionet's ultra linear amplifier concept in the AMP V, too. The circuitry is designed to achieve exemplary low distortion, celerity and stability. The internal structure of the AMP V was developed in a way that all five channels work independently as far as possible. Only exclusively selected high-grade components are used. Influences harmful to the sound quality of the amplifier have been completely eliminated, and an exemplary stability of performance is granted.

AMP V is controlled and monitored by a capable microprocessor. It provides an easy handling, comforting reliability and even checks the correct polarization of the mains plug. Of course, the AMP V can be remotely controlled by the Audionet Link interface.

But before you start listening to your new Audionet AMP V, please read this manual carefully so you are able to use and enjoy all functions of this unit without drawback on music quality.

1.1 Included

Included you will find the following items:

- the multichannel amplifier AMP V
- the user's manual (that you are currently reading)
- one standard mains chord.

1.2 Transport



Important

- Please transport the AMP V only in the included package.
- Always use the plastic bag to prevent scratches on the housing.
- Please allow the AMP V to adapt to the climatic conditions in your listening room before you switch on the unit for the first time after transport.

2 Overview control elements

2.1 Front panel

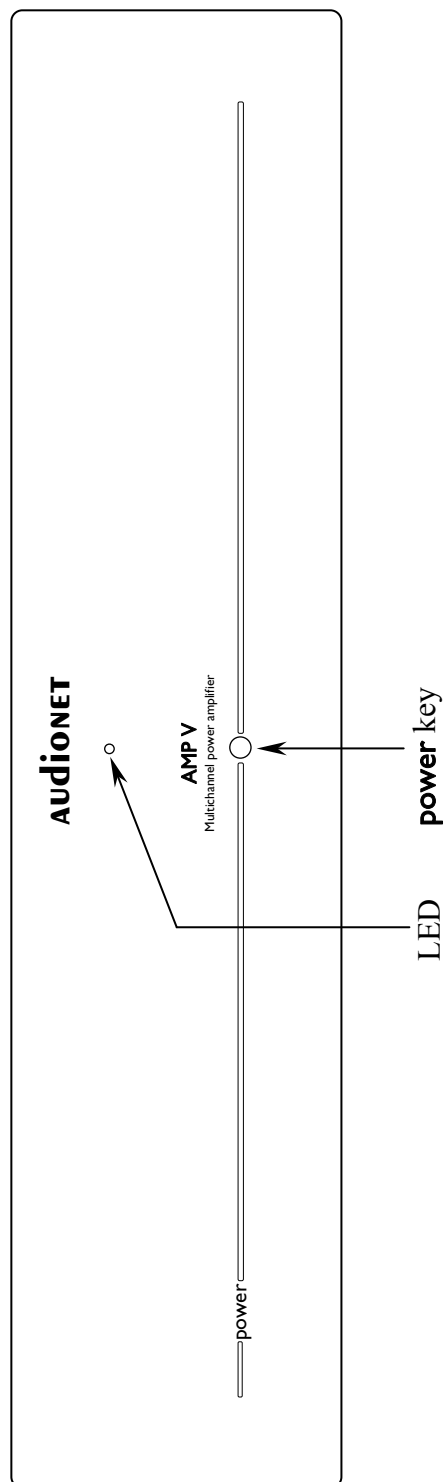

3 Overview connections

3.1 Back panel

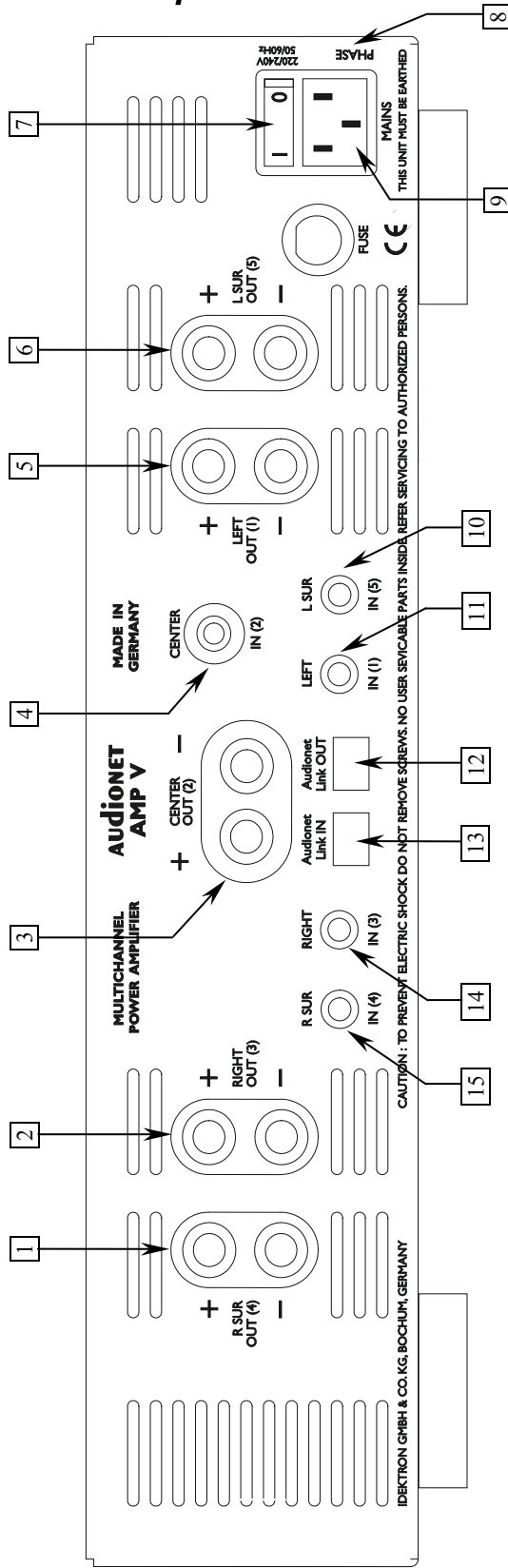

- | | | | |
|----------|---|-----------|---------------------------------------|
| 1 | Speaker terminal channel 4 (Right Surround) | 11 | Marking mains phase |
| 2 | Speaker terminal channel 3 (Right) | 12 | Mains input |
| 3 | Speaker terminal channel 2 (Center) | 13 | Line input channel 5 (Left Surround) |
| 4 | Line input channel 2 (Center) | 14 | Line input channel 1 (Left) |
| 5 | Speaker terminal channel 1 (Left) | 15 | Audionet Link output |
| 6 | Speaker terminal channel 5 (Left Surround) | 16 | Audionet Link input |
| 7 | Mains switch | 17 | Line input channel 3 (Right) |
| | | 18 | Line input channel 4 (Right Surround) |

4 Installation and power supply



Important

- For connecting or removing loudspeakers and/or the pre amplifier the your AMP V must be switched off to prevent damage on the amplifier or the connected units.
- Please make sure that all cables are in absolute best conditions! Broken shields or short-cut loudspeaker cables could damage speakers and/or amplifiers.

4.1 Placement

Please find a place for your Audionet AMP V that is sufficiently ventilated to allow the heat to dissipate. It is recommended to place the AMP V into a high quality rack or onto a stable table. Do not expose the unit to direct sunlight. Do not place the unit in close range to heat sources like radiators. Do not cover the ventilation slots of the AMP V.

4.2 Mains connection

The mains input **9*** is on the back panel of the AMP V. To connect the unit to mains use the included mains cord. If you want to use a different power cord make sure that it meets the specifications for your home country.



Important

- The electrical specifications printed onto the back panel must meet the electrical specifications of your home country.
- The AMP V is a Class I unit and must be earthed. Please ensure a stable earth connection. 'Phase' ('hot' pin) is marked on the back panel ('PHASE') **8**.
- Never pull the mains plug while the AMP V is switched on. Always power down the unit to stand-by mode first, before you use the mains switch **7** on the back panel or pull the mains plug.

* see numbers in section 'Back panel'

Only in case of extended absence (like vacations) or if massive trouble on the mains power is to be expected you should disconnect the unit from mains. To disconnect the AMP V completely from mains pull the mains plug.

4.3 Orientation of mains plug

The correct polarization of mains is important for reasons of audio clarity and stability. Please connect the mains cord that the hot pin of the wall outlet is connected to the pin of mains input 9 marked '**PHASE**' 8 on the back panel of the unit.



Note

- Your Audionet AMP V is able to detect a wrong polarization of the mains plug. The LED in the front panel will flash quickly while powering up from stand-by mode using the **power** key. In this case, power down the unit and flip the mains plug (see section '*Mains phase detection*').

5 Inputs and outputs



Important

- For connecting or removing loudspeakers and/or the pre amplifier the your AMP V must be switched off to prevent damage on the amplifier or the connected units.
- Please make sure that all cables are in absolute best conditions! Broken shields or short-cut loudspeaker cables could damage speakers and/or amplifiers.

5.1 Line inputs

At first, connect your pre amplifier to the line inputs **4**, **10**, **11**, **14** and **15** of the AMP V. Go by the names of the channels printed above the input jacks.



Note

- In case you would like to use a speaker configuration besides the usual 5.1 system, please refer to the following table for a recommended speaker setup:

Configuration	AMP V line inputs				
	1	2	3	4	5
5.1 standard system	L	C	R	RS	LS
7.1 system with separate stereo amplifier for L/R	LS	C	RS	RB	LB
7.1 system with separate stereo amplifier for LB/RB	L	C	R	RS	LS
4 channel system	L	n.c.	R	RS	LS
3 channel system	L	C	R	n.c.	n.c.
Stereo bi-amping	L high pass	n.c.	R high pass	R low pass	L low pass
L = Left LS = Left Surround LB = Left Back C = Center RS = Right Surround RB = Right Back R = Right n.c. = not connected					

- Of course, channel assignments differing from the table above are possible. Assign channels preferably in order of their numbers.
- If you are setting up a bi-amping system, please use channel pair 1 & 5 or 3 & 4 for one speaker each. Connect the high pass input of your speakers prefferably to channel 1 or 3; use channels 4 & 5 for the low pass input repectively. Also, keep warnings regarding bi-amping in the following section in mind!

5.2 Speaker terminals

Now, connect your speakers to the gold plated terminals on the back panel. The assignment to the respective line input is clearly indicated.



Note

- Look out for the correct connection of your speaker cables. Usually, the terminals of your speakers (1, 2, 3, 5 and 6) are marked '+' and '-'. The AMP V uses the same marks.
- Wrong speaker polarization will result in severe loss of sound quality!



Important

- **Although the AMP V has an effective protection system to prevent damage to the circuits, switch off the unit while working on the speaker and/or audio cables.**
- **If you use 2 or more amplifiers of your AMP V for bi-amping, please make absolutely sure, that you removed any jumpers at the terminals of your speakers (please consult the user's manual of your speakers), before you switch on the system. Otherwise the speakers and/or amplifiers could suffer damage!**
- The nominal loudspeaker impedance should be 4 Ohms or higher.
- Never use force or tools tightening the terminal screws.

6 Operating

6.1 Switching on/off

First switch on the AMP V using the mains switch 7 on the back panel. For about 2 seconds the LED will flash rapidly while the unit is initialized. Afterwards, the AMP V is in stand-by mode; the LED is off.

Press **power** key on the front panel to switch on the unit. The LED on the front panel reports the polarization of mains phase for a few seconds (see sections '*Mains phase detection*') until the speaker outputs are enabled. The AMP V is now ready to playback music.

To switch off the AMP V press **power** key on the front panel again. The unit is in stand-by mode; the LED is off.



Note

- During shut down procedure the LED will flash 7 times. Before you can switch on the AMP V again, you have to wait until the shut down procedure is finished and the LED is off. Do not switch off the amplifier with the mains switch 7 at the back panel during shut down procedure.

6.2 Mains phase detection

The AMP V is able to detect the correct polarization of the mains plug. After pressing the **power** key until the speaker outputs are enabled, the LED will flash in different rhythms:

- If the polarization is correct, the LED flashes slowly: ⊗__⊗__⊗...
- If you see the LED flashing rapidly: ⊗_⊗_⊗_⊗_⊗... please switch off the unit and flip the mains plug. If you now switch on the AMP V again, the unit should show the correct mains polarization by a slowly flashing LED.

6.3 Audionet Link

For your convenience, the AMP V can be controlled remotely by one of Audionet's multi-channel pre amplifiers MAP or MAP 1, as well as one of Audionet's stereo pre amplifiers PRE or PRE 1 using the 'Audionet Link' interface.

You only need a simple optical 'Toslink' cable to connect the 'Audionet Link' output of your Audionet pre amplifier to the 'Audionet Link' input 13 of your AMP V. Now, the AMP V will be switched on/off automatically, when you switch on/off your pre amplifier at the front panel or by remote control.

In case you would like to automatically control further Audionet units in your system with the 'Audionet Link' interface, please connect the 'Audionet Link' output 12 of your AMP V to the 'Audionet Link' input of the next Audionet unit using a simple optical 'Toslink' cable.



Note

- The 'switch on' signal is issued to any further Audionet units daisy chained to the 'Audionet Link' output of your AMP V with a little delay to avoid all units switching on at the same moment, which could cause an overload of your mains fuse.
- Independently from the 'Audionet Link' interface, you can switch on/off your AMP V at any time by using the **power** key on the front plate.

7 Protection system

Your Audionet AMP V is equipped with a powerful protection system that safeguards your speakers and itself.

In case of an error the AMP V will report the cause in two steps. First, the LED on the front panel will flash the number of the error occurred. Just count how often the LED flashes and check that number with the following table:

- 1x DC failure:**
dangerous DC voltage level at the speaker output: defective pre amplifier, source or active crossover carrying DC
- 2x High frequency (HF):**
high frequency oscillation, please check your input source
- 3x Overload:**
short-circuit of a loudspeaker cable or speaker is defective
- 4x Temperature:**
do not cover the ventilation slots of your AMP V

Press **power** key at the front panel. Now, the AMP V reports the number of the erroneous channel. Count how often the LED flashes to get the channel number. The channel number is printed on the back panel right beside the speaker terminals **1**, **2**, **3**, **5** and **6**, and also printed below the line inputs **4**, **10**, **11**, **14** and **15**.

Press **power** key again to enter stand-by mode.



Important

- Remove cause of error before switching on the AMP V again!



Note

- The AMP V will report the error code or channel number repeatedly until you press the **power** key at the front panel.
- Between each repetition of the error report is a small pause of about 1 second. During this pause the LED is off.



Example

An error occurred. The AMP V switches off the speakers, and the LED on the front panel flashes:

⊗_⊗_____⊗_⊗_____⊗_⊗_____⊗_⊗ ...

According to the table above 2 flashes denote 'High Frequency Error'.

Now, press the power key. The AMP V will report the channel number. The LED flashes:

⊗_⊗_⊗_⊗_ _____ ⊗_⊗_⊗_⊗_ _____ ⊗_⊗_⊗_⊗_ ...

Between the pauses, you can count 4 flashes of the LED which denotes that the error occurred in channel nr. 4.

To enter stand-by mode please press the **power** key again.

Legend: ⊗ = LED on _ = LED off

8 Security notes



Important

- Avoid packaging material, especially plastic bags, coming into children's hands!
- Store and operate the unit in a dry room at a reasonable room temperature only!
- Avoid moisture, any liquids, dirty or small objects getting into the unit!
- Set up the unit in a sufficiently ventilated environment!
- Do not cover the unit!
- Do not open the unit. Unauthorised opening will void warranty!
- Do not short circuit the outputs!
- If you use 2 or more amplifiers of your AMP V for bi-amping, please make absolutely sure, that you removed any jumpers at the terminals of your speakers (please consult the user's manual of your speakers), before you switch on the system. Otherwise the speakers and/or amplifiers could suffer damage!
- For connecting or removing loudspeakers and/or the pre amplifier the your AMP V must be switched off to prevent damage on the amplifier or the connected units.
- Use dry cloth for cleaning!

We would like to wish you many exciting listening experiences you're your new Audionet product.

If you still have any questions, do not hesitate to ask your competent Audionet dealer or contact us directly.

9 Technical data

Function	5-channel power amplifier
Power	100 Watts in 8 Ohms per channel 180 Watts in 4 Ohms per channel
Frequency response	2 – 300,000 Hz (-3dB)
Damping factor	> 2,000 from 10 Hz to 10 kHz
THD+N	< -100 dB (25 Watts / 4 Ohms)
SNR	> 120 dB (A-weighted)
Channel separation	> 100 dB for 1 kHz
Input impedance	37 kOhms, 150 pF
Inputs	5 Cinch Line, AC coupled, gold plated 1 Audionet Link, optical
Outputs	5 pairs of WBT speaker terminals, gold plated 1 Audionet Link, optical
Mains	230 V, 50..60 Hz
Power consumption	1 Watt Stand by, max. 1,200 Watts
Dimensions	Width: 430 mm Height: 110 mm Depth: 360 mm
Weight	19 kg
Finish Front	brushed aluminium, 10 mm, black anodized, light grey print or aluminium 'nature' anodized, black print, LED red or blue
Features	Processor controlled protection circuit for HF, DC, temperature and overload Remote control by Audionet Link (optical) Automatic mains phase detection

Errors and omissions excepted. Specifications and design are subject to changes without prior notice.

AUDIONET is a trademark of Idektron GmbH & Co KG

Engineered and produced by:
Idektron GmbH & Co. KG, Herner Str. 299, Gebäude 6, 44809 Bochum, Germany
www.audionet.de
contact@audionet.de