

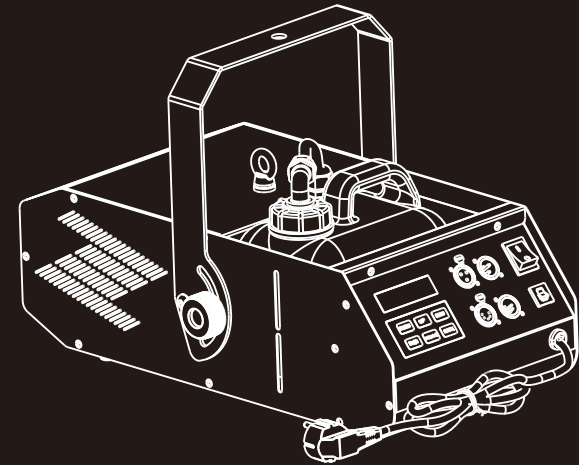

[ PRO STAGE EFFECTS ]



COMPLAINTS E-MAIL: FOG\_CAT@126.COM



WWW.DJPOWER.CN

**DSK-1500CT** *USER MANUAL*

**PRO FOG MACHINE (Specialized version for bar)**

GUANGZHOU DJPOWER ELECTRONIC TECHNOLOGY CO.,LTD

## ◆ Foreword

Thank you very much for choosing DJPOWER DSK-1500CT PRO Fog Machine(Specialized version for bar ).

Before start operating, we strongly suggest you to read the user manual carefully. Following the instructions here will ensure your safety while operating the machine, easily achieve the best effect, as well as understand the right way to maintain the machine, hence to prolong the product life cycle.

## ◆ Products description

Finally! DJPOWER New model DSK-1500CT is coming! DSK-1500CT, specially designed for long-term working circumstance, is a professional fog machine for bars. Small and easy for hanging. Immediate-stop patent makes it no water drops or burnt flavor. The design of avoiding blockage fits for durable requirement of bars. Big smoke output. It is the most wonderful and professional fog machine for bars! Good machine deserves good fluid. Please use only DJPower professional fog fluid, keep far away from water-leakage and blockage!

## ◆ Features

1. Using a variety of temperature protection;
2. Mini professional fog machine, using anti-jamming of precision circuit;
3. With fluid sensor to protect the pump from burning when there is no fog fluid;
4. High efficiency heater, generating more high quality smoke;
5. With DJPOWER's unique "immediate-stop" technical patent no need to worry about water drop;
6. Pls use DJPOWER professional fluid PRO-A or PRO-D, otherwise the machine will be more or less damaged .

## ◆ Safety operation

- Keep the fixture dry. For indoor and outdoor use.
- Use grounded electrical outlet. Prior to use, make sure that unit is installed at the rated voltage.
- Turn off or unplug when not using it.
- This machine is not water-proof. Please keep it away from moisture and water. If moisture, water, or fluid gets inside the housing, stop using it.
- No user serviceable and modifiable parts inside. Do not disassemble the housing and do any modification, otherwise it might cause damage to the unit or danger of burning.
- For adult use only. Fixture must be installed out of the reach of children.

Never leave the unit running unattended. Keep it away from fire, combustible and flammable materials.

- Position the machine in well-ventilated area. Please leave about 50cm spaces surrounding the unit.
- Please do not use the fixture under high temperature.
- Never add flammable liquids of any kind(oil, gas, perfume) to the fog liquid.
- If something wrong happen while using, please stop the fixture immediately, cut off the power, and check the fog liquid amount, fuse, power cable and power plug. If problem could not be resolved, please contact with your dealer.
- Use only DJPOWER high-quality PRO-A or PRO-D fog liquid.
- Never drink liquid. If it is ingested, call a doctor immediately for any discomfort. If liquid comes in contact with skin or eyes, rinse thoroughly with water.

## ◆ Unpack and inspect the machine

Once receiving the machine, carefully unpack the carton, check all content to ensure that all parts are present and have been received in good condition. If any parts appear damaged or mishandled from shipping, please do not power on the machine. Contact with the dealer immediately.

## ◆ The following parts should be included when you receive the package

1. One DSK-1500CT fog machine
2. One W-4 wireless remote
3. One power cord
4. One user manual

## ◆ Control Panel Instruction

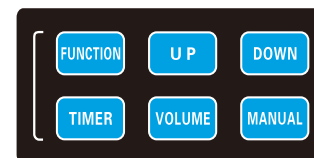

There are total 6 buttons on the control panel. They are FUNCTION, TIMER, UP, DOWN, VOLUME and MANUAL respectively. User can set up the machine on the interface according to their needs: When the heating up is finished, the LCD (Liquid Crystal Display) screen shows "Ready To Fog W" ("W" means the machine is under wireless control mode.)

1. When LCD displays "Ready To Fog", press **[FUNCTION]** button once, the LCD screen shows **[INTERVAL SET]** range is between 1 and 200 seconds) **[UP/DOWN]** buttons.
2. When LCD displays "Ready To Fog", presses **[FUNCTION]** button twice, the LCD screen shows **[DURATION SET]** . Under this status, user can adjust the fog output duration of Timer mode (the range is between 1 and 200 seconds) by **[UP/DOWN]** buttons.
3. When LCD displays "Ready To Fog", press **[FUNCTION]** button three times, the LCD screen shows **[TIMER]** . Under this status, user can adjust the fog output volume of Timer mode (the range is between 5% and 100% ) by **[UP/DOWN]** buttons.

User can trigger Timer mode when LCD shows "Ready To Fog" and presses **[TIMER]** button and when machine is working under Timer mode, pressing **[TIMER]** button again can end the timer mode.

4. When LCD displays "Ready To Fog", press **[FUNCTION]** four times, the LCD screen shows "VOLUME OUT". Under this status, user can adjust the fog output volume of Volume mode (the range is between 5% and 100%) **[UP/DOWN]** buttons. User can trigger Volume mode when LCD shows "Ready To Fog" and press **[VOLUME]** button, and when machine is working under Volume mode, pressing **[VOLUME]** button again can end Volume mode.

Note: There is a memory function here, machine could remember the smoke output volume set. When turn on the machine next time, the setting will repeat until it is cleaned up or set up again.

5. When LCD displays "Ready To Fog", press **[FUNCTION]** five times, the LCD screen shows **[DMX 512 ADD]** , Under this status, user can adjust the DMX address by **[UP/DOWN]** buttons.
6. When LCD displays "Ready To Fog", press **[FUNCTION]** button six times, the LCD screen shows Wireless On, Under this status, pressing either **[UP]** or **[DOWN]** button once can switch off the wireless function. On the other hand, when the LCD shows Wireless Off, pressing either **[UP]** or **[DOWN]** button once can switch on the wireless function.
7. When LCD displays "Ready To Fog", continue to press on the **[MANUAL]** button can force machine generate 100% full fog output. As soon as releasing **[MANUAL]** button, machine stops fogging immediately.
8. DSK-1500CT fog machine equipped with "fluid sensor" inside. When there is no fluid in the oil tank the pump will automatically stop working. At this time, the LCD screen will show **[No Fluid]** . Please add sufficient fog fluids into fluid tank and then continue to press on the **[MANUAL]** button until the **[No Fluid]** " is revealed on the LCD screen (not warning).

9. If the "oil-free protection" is not needed, user can switch it off, When LCD displays "Ready To Fog", press **[FUNCTION]** seven times, the LCD screen shows "Fluid Sensor On". Under his status, pressing either **[UP]** or **[DOWN]** button once can switch off the fluid sensor. On the other hand, when the LCD shows "Fluid Sensor Off", pressing either **[UP]** or **[DOWN]** button once can switch on the fluid sensor.

10. When the heating process of the fog machine is completed and ready to fog, the status of wireless function and fluid sensor on the LCD screen are as followings:

- When the wireless function is on, LCD displays "Ready To Fog W" (W Means Wireless)
- When the fluid sensor is on, LCD displays "Ready To Fog S" (S means Oil-free sensor)
- When the above two features both are on, LCD displays "Ready To Fog WS"
- When the above two features both are off, LCD displays "Ready To Fog"

#### ◆ Instructions of Wireless Remote

- Transmitter:  
Use DC 12V battery  
Working Distance: 50 meters in open area (Wireless distance may vary depending compatible on the interference).  
All transmitters are to any receiver.
- Receiver  
The receiver is pre-equipped firmly and tested to each (rear panel).  
Wireless Remote Functions and Setting:



1. All receivers can receive signals from any registered transmitter
2. Each receiver at most can record 5 transmitters
3. The included transmitter has been registered before shipment. User can use it directly without any setting. The initial setting is pressing button "ON" can start the machine and pressing button "OFF" can stop it.
4. If user wants to use other transmitters (except the included one) to control machine, the setting must be completed within 15 seconds after switching on machine. 15 seconds after switching on machine, it will leave "transmitter setting mode" automatically.

#### Setting Example 1:

If user wants to use other 3 transmitters, when machine is turned on and

LCD (Liquid Crystal Display) screen shows "Wireless Setup", user has to press the button A of each transmitter for 1 second rapidly within 15 seconds to complete the registration of the 3 transmitters

Please note that 15 seconds after switching on machine, when LCD screen shows "Wireless Setup OK". It represents that machine has left "transmitter setting mode". At this point, user can not add any transmitter to the receiver.

#### Setting Example 2:

If user wants to use 1 transmitter to control 2 or more machines, user has to turn on 2 (or more) machines at the same time, and press the button locking of the transmitter when the LCD screen shows "Wireless Setup" for 1 second within 15 seconds. (The same procedure as registering transmitter to 1 machine).

5. If no any new transmitter is registered when machine is switched on, the memory of the receiver will remain the same record or last operation
6. Please note if a new transmitter is registered when machine is switched on, no matter how many new transmitters is registered (at most 5), a 11 previous transmitters registered record will be cleared (overridden).

#### ◆ DMX Settings

This fog machine has interior devices DMX. It uses 1 channel to control somke output. This channel has a value range of 0 to 255. Timer functions such as duration and interval can be programmed using the DMX controller or the DMX control software used by the lighting and effects operator.

If channel A has a value from 0 to 5 the unit is OFF.

Between the code 6 to 255 the volume of fog output is regulated. With 6 being the minimum volume of fog produced and 254 approaching the maximum, The smoke output rises as the DMX value increased.

#### ◆ Note

If you experience low output, pump noise or no output please disconnect the power immediatly. Check fluid level, the external fuse, and power from the wall. If all of the above appears to be OK, plug the unit again. If fog does not come out after pressing the remote button for 30 seconds, check the hose attached to the tank to make sure there is fluid going through the hose. If you are unable to determine the cause of the problem, do not continue pressing the remote, as this may damage the unit. Return the machine to our dealer.

#### ◆ Technical parameters

Model: DSK-1500CT  
Voltage used: AC220-240V 50/60Hz

Fuse:	8A/250V
Power:	1400W
Pre-heating time:	5min
Smoke output:	25000cuft/min
Fluid consumption:	8min/L
Max spray distance:	6m
Wireless remote:	W-4
DMX-512:	√
Tank capacity:	3L
N.W.:	9kg
G.W.:	10kg
Machine Size:	480/297/310mm
Package size:	545/340/300mm

#### ◆ Graphic Illustration

1. Nozzle
2. Body
3. Tank & tank's cap
4. PU tube & filter
5. Tube adaptor
6. Safety ring
7. 3-pin XLR for DMX
8. 3-pin XLR for DMX
9. 5-pin XLR for DMX
10. 5-pin XLR for DMX
11. Power switch
12. Power socket
13. Control panel
14. Power panel
15. W-4 Wireless transmitter

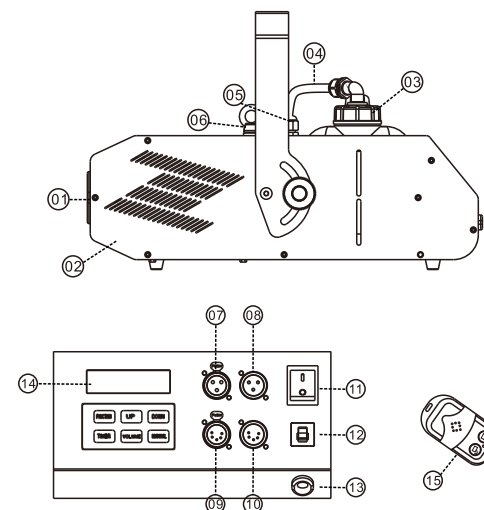

#### ◆ Fog machine fluid blowout and heater blocking phenomenon analysis

Please use the original consumables, protect your health and life of machine

A.Fluid injection trouble: Refers to the fog fluid atomizing in the heater pipe of the machine is not good, heater temperature cannot be timely and effective transmit to the fog fluid, fog fluid cannot all atomization and lead to fluid injection

First reason: Using the low quality or counterfeit fog fluid, low quality fog fluid have more impurities, easy to adhere to the pipe wall and hindered temperature transmission result in incomplete atomization caused fluid injection.

Second reason: using an incorrect fog fluid. Different fog fluid have different required atomization temperature. If you use the wrong fog fluid result in oil cannot fully atomization caused fluid injection.(fig 1)

B.Heater blocking trouble: poor atomization fluid injection is the early signs of heater block. Using poor quality fog fluid or not timely maintenance cleaning the fog machine for a long time. Inevitable will appear the terminal symptom of heater blocking.

Reason: heater blocked is because used inferior fog fluid or not maintenance for a long time. Have nothing to do with the quality of machine. Like a car with poor quality gasoline produce poor fluid circuit failure or long-time no maintenance the car will inevitably appear bigger problems. (fig 2)

C.Solutions to these problems: fog machine heating pipes used for a long time and then the pipe wall will easily produce sediments (The more inferior fog fluid the more impurities thus lead to fluid injection or blocked). All fog machines need regular maintenance (fog machine maintenance cycle for 1 to 2 months/time). Specific maintenance method: after heating the 35% white vinegar plus 65% distilled water and then spray 10 to 15 times

Conclusion: As long as the fog machine with fluid injection or heater blocking after using a period of time. It was caused by fog fluid quality or lack of maintenance, has nothing to do with the quality of the machine. Please use the original high quality fog fluid and timely maintain it, then it can be used for a long time.

