

INTIMIDATOR

SPOT 355 IRC

User Manual

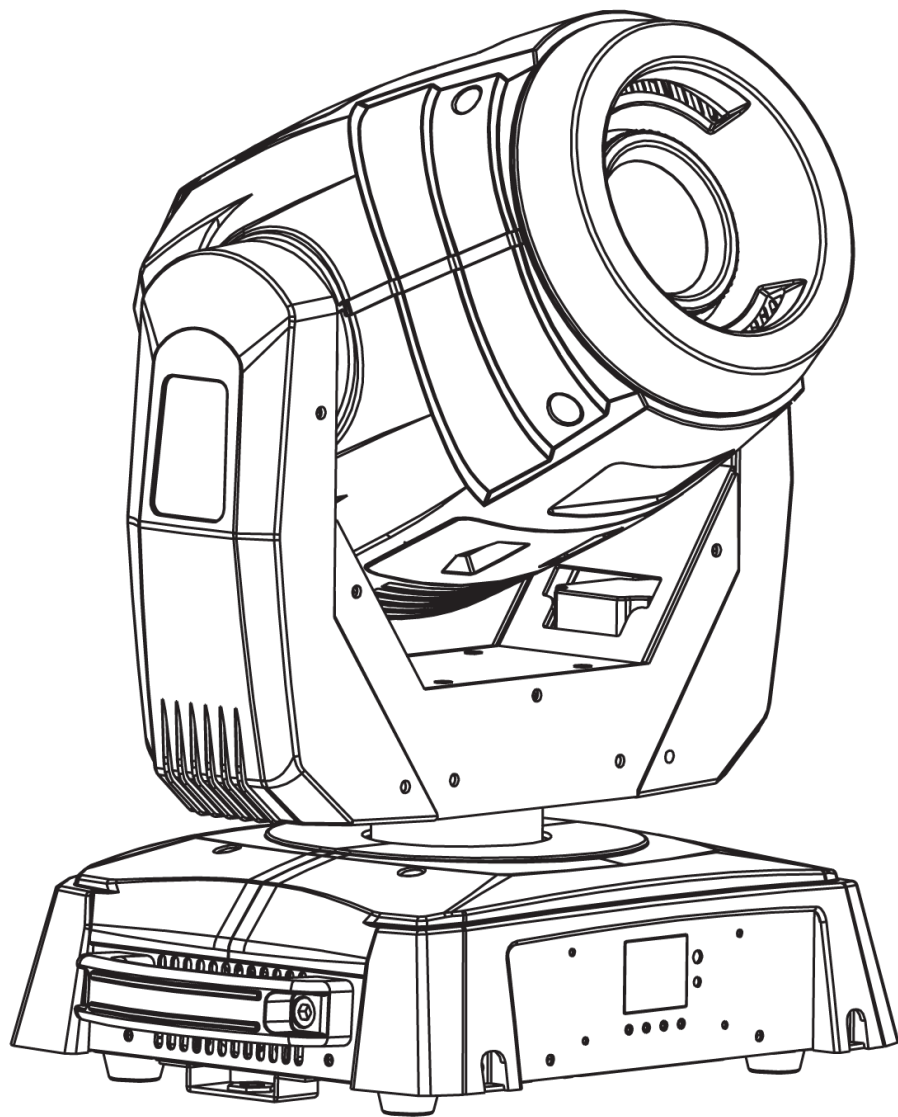

TABLE OF CONTENTS

1. Before You Begin	3
What Is Included	3
Unpacking Instructions	3
Claims	3
Text Conventions	3
Symbols	3
Disclaimer	3
Product at a Glance	4
Safety Notes	4
2. Introduction	5
Product Overview	5
Product Dimensions	6
3. Setup	7
AC Power	7
Fuse Replacement	7
Power Linking	7
Mounting	8
Orientation	8
Rigging	8
4. Operation	9
Control Panel Operation	9
Menu Map	9
Configuration (DMX)	10
Starting Address	10
DMX Personalities	10
5. DMX Assignments	11
DMX14CH	11
DMX8CH	12
Configuration (Standalone)	14
Sound-Active Mode	14
Sound Sensitivity	14
Automatic Mode	14
Totem Mode	14
Manual Test Mode	15
Pan/Tilt Orientation	15
Pan/Tilt Angle Range	15
Display	16
Reset Options	16
System Information	16
Master/Slave Mode	17
IR Mode	18
IRC-6 Operation	18
Zero Adjust Mode	19
Changing Gobos	20
6. Technical Information	21
Product Maintenance	21
7. Technical Specifications	22
Returns	23
Contact Us	24

1. BEFORE YOU BEGIN

What Is Included

- Intimidator Spot 355 IRC
- Hanging Bracket with Mounting Hardware
- Power Cord
- Warranty Card
- Quick Reference Guide

Unpacking Instructions

Carefully unpack the product immediately and check the container to make sure all the parts are in the package and are in good condition.

Claims



If the box or the contents (the product and included accessories) appear damaged from shipping, or show signs of mishandling, notify the carrier immediately, not Chauvet. Failure to report damage to the carrier immediately may invalidate your claim. In addition, keep the box and contents for inspection.

For other issues, such as missing components or parts, damage not related to shipping, or concealed damage, file a claim with Chauvet within 7 days of delivery.

Text Conventions

Convention	Meaning
1–512	A range of values
50/60	A set of values of which only one can be chosen
Settings	A menu option not to be modified
Menu > Settings	A sequence of menu options to be followed
<ENTER>	A key to be pressed on the product's control panel
ON	A value to be entered or selected

Symbols

Symbol	Meaning
	Critical installation, configuration, or operation information. Not following these instructions may make the product not work, cause damage to the product, or cause harm to the operator.
	Important installation or configuration information. The product may not function correctly if this information is not used.
	Useful information.

Disclaimer

Chauvet believes that the information contained in this manual is accurate in all respects. However, Chauvet assumes no responsibility and specifically disclaims any and all liability to any party for any loss, damage or disruption caused by any errors or omissions in this document, whether such errors or omissions result from negligence, accident or any other cause. Chauvet reserves the right to revise the content of this document without any obligation to notify any person or company of such revision, however, Chauvet has no obligation to make, and does not commit to make, any such revisions.

The works of authorship contained in this manual, including, but not limited to, all design, text and images are owned by Chauvet.

© Copyright 2016 Chauvet & Sons, LLC. All rights reserved.

Electronically published by Chauvet in the United States of America.

CHAUVET, the Chauvet logo, Gobo Zoom USB, D-Fi, and D-Fi USB are registered trademarks or trademarks of Chauvet & Sons LLC. (d/b/a Chauvet and Chauvet Lighting) in the United States and other countries. Other company and product names and logos referred to herein may be trademarks of their respective companies.

Product at a Glance

Use on Dimmer	⊘	Auto Programs	✓
Outdoor Use	⊘	Auto-ranging Power Supply	✓
Sound-Activated	✓	Replaceable Fuse	✓
DMX	✓	User-Serviceable	⊘
Master/Slave	✓		

Safety Notes

These notes include important information about the mounting, usage, and maintenance of this product; read before using the product.



- Always connect the product to a grounded circuit to avoid the risk of electrocution.
- Always disconnect the product from power before cleaning or replacing the fuse.
- Avoid direct eye exposure to the light source while the product is on.
- Make sure the power cord is not crimped or damaged.
- Never disconnect the product from power by pulling or tugging on the cord.
- If mounting the product overhead, always secure to a fastening device using a safety cable.
- Make sure there are no flammable materials close to the product when operating.
- Do not touch the product's housing when operating because it may be very hot.



- Always make sure that the voltage of the outlet to which you are connecting the product is within the range stated on the decal or rear panel of the product.
- The product is for indoor use only! (IP20) To prevent risk of fire or shock, do not expose the product to rain or moisture.
- Always install the product in a location with adequate ventilation, at least 20 in (50 cm) from adjacent surfaces.
- Be sure that no ventilation slots on the product's housing are blocked.
- Never connect the product to a dimmer or rheostat.
- Make sure to replace the fuse with another of the same type and rating.
- Never carry the product from the power cord or any moving part. Always use the hanging/mounting bracket.
- The maximum ambient temperature (T_a) is 104 °F (40 °C). Do not operate the product at higher temperatures.
- In the event of a serious operating problem, stop using the product immediately.
- Never try to repair the product. Repairs carried out by unskilled people can lead to damage or malfunction. Please contact the nearest authorized technical assistance center.
- To eliminate unnecessary wear and improve its lifespan, during periods of non-use completely disconnect the product from power via breaker or by unplugging it.



Keep this User Manual for future use. If you sell the product, give this document to the next owner.

2. INTRODUCTION

Product Overview

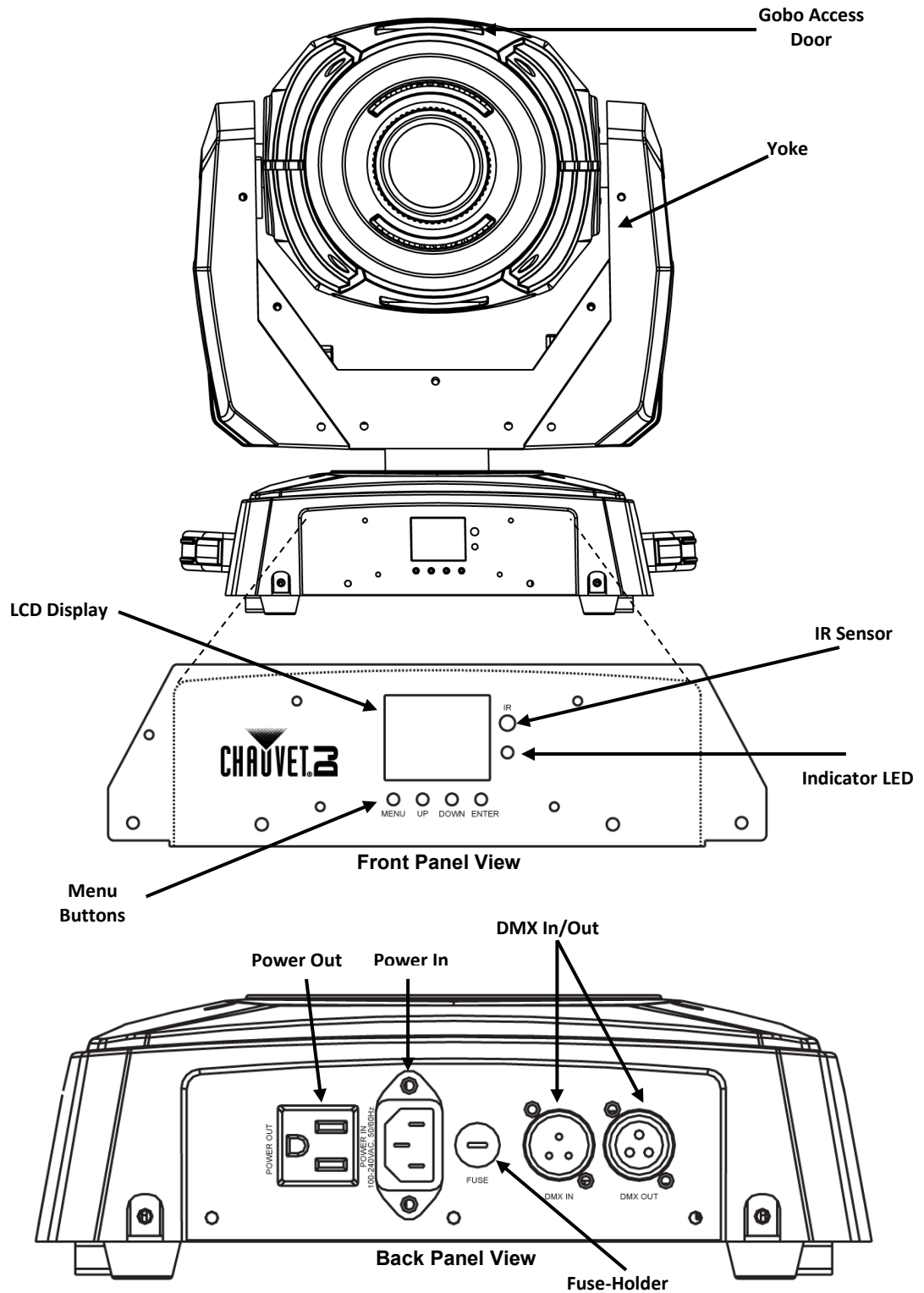

Product Dimensions

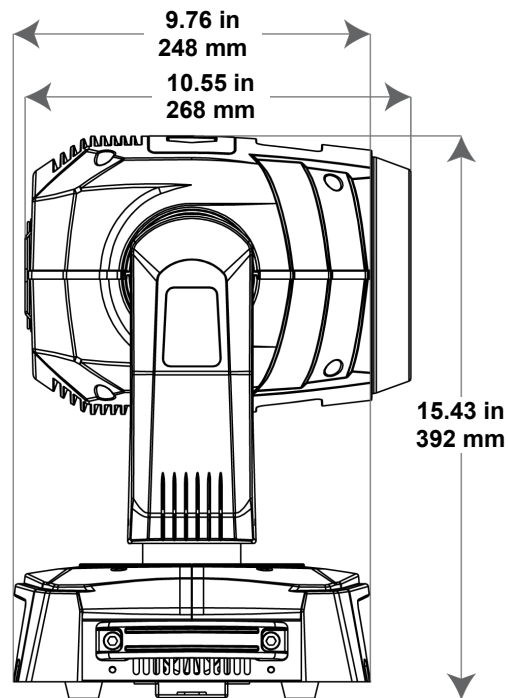
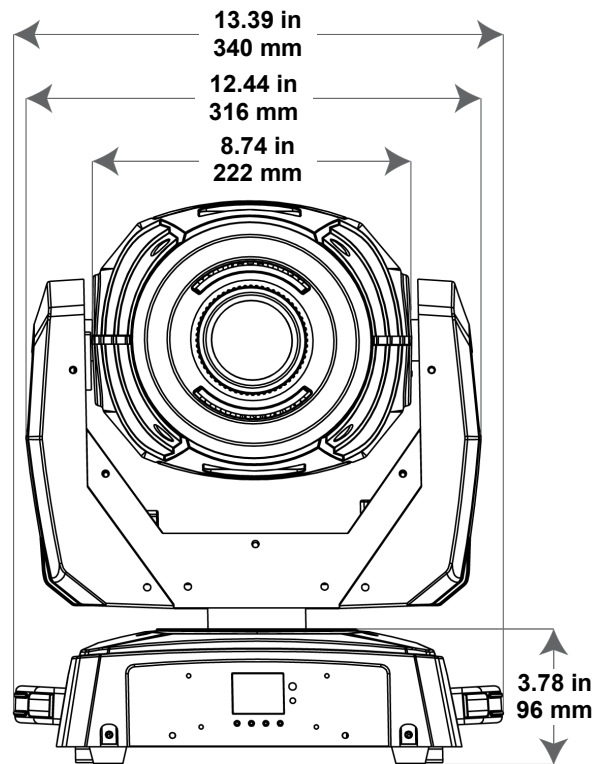

3. SETUP

AC Power The Intimidator Spot 355 IRC has an auto-ranging power supply and it can work with an input voltage range of 100 to 240 VAC, 50/60 Hz.

To determine the product's power requirements (circuit breaker, power outlet, and wiring), use the current value listed on the label affixed to the product's back panel, or refer to the product's specifications chart. The listed current rating indicates the product's average current draw under normal conditions.



- **Always connect the product to a protected circuit (circuit breaker or fuse). Make sure the product has an appropriate electrical ground to avoid the risk of electrocution or fire.**
- **To eliminate unnecessary wear and improve its lifespan, during periods of non-use completely disconnect the product from power via breaker or by unplugging it.**



Never connect the product to a rheostat (variable resistor) or dimmer circuit, even if the rheostat or dimmer channel serves only as a 0 to 100% switch.

Fuse Replacement

1. Disconnect the product from power.
2. Using a flat-head screwdriver, unscrew the fuse holder cap from the housing.
3. Remove the blown fuse.
4. Replace with a fuse of the same type and rating.
5. Screw the fuse holder cap back in place and reconnect power.



- **Disconnect the product from power before replacing the fuse.**
- **Always replace a blown fuse with another of the same type and rating.**

Power Linking The product provides power linking via the IEC outlet located in the back of the unit.

Power Linking Diagram

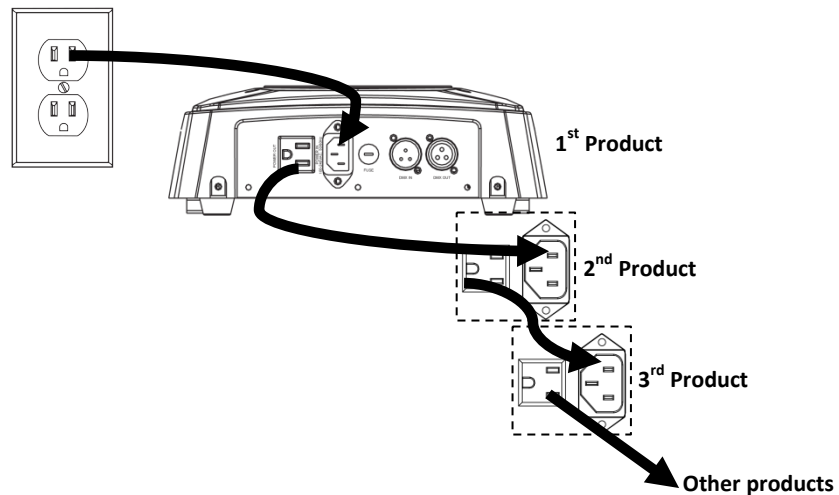

You can power link up to 4 Intimidator Spot 355 IRC units on 120 VAC or up to 7 Intimidator Spot 355 IRC units on 230 VAC.



The power linking diagram shown above corresponds to the North American version of the product ONLY! If using the product in other markets, you must consult with the local Chauvet distributor as power linking connectors and requirements may differ in your country or region.

Mounting Before mounting the product, read and follow the safety recommendations indicated in the Safety Notes.

Orientation The Intimidator Spot 355 IRC may be mounted in any position; however, make sure adequate ventilation is provided around the product.

- Rigging**
- Before deciding on a location for the product, always make sure there is easy access to the product for maintenance and programming purposes.
 - Make sure that the structure or surface onto which you are mounting the product can support the product's weight. See the [Technical Specifications](#) for weight information. The CLP-15 clamp from Chauvet is appropriate for this product.
 - When mounting the product overhead, always use a safety cable. Mount the product securely to a rigging point, whether an elevated platform or a truss.
 - When rigging the product onto a truss, you should use a mounting clamp of appropriate weight capacity.
 - When power linking multiple products, you must always consider the length of the power linking cable and mount the products close enough for the cable to reach.
 - The rubber feet also serve as floor supports. When mounting the product on the floor, make sure that the product and cables are away from people and vehicles.

Mounting Diagram

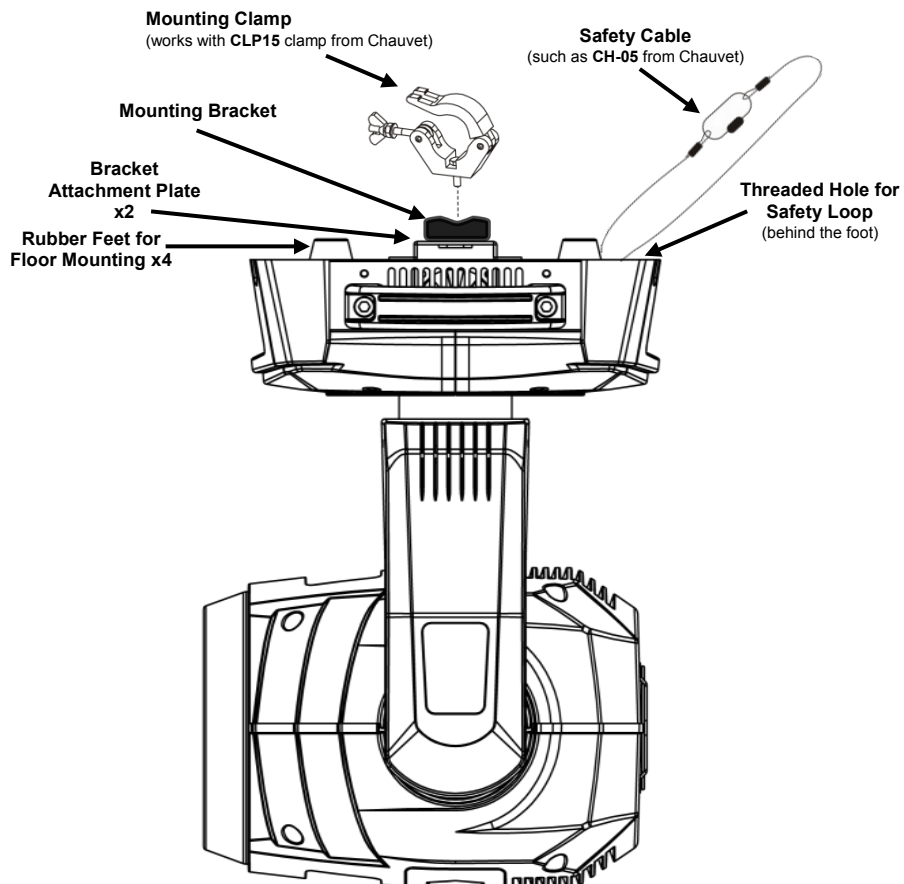

When using only one mounting clamp with this fixture, you must use a clamp with a captive bolt to prevent accidental loosening.

4. OPERATION

Control Panel Operation To access the control panel functions, use the four buttons located underneath the display.

Button	Function
<MENU>	Press to find an operation mode or to back out of the current menu option
<UP>	Press to scroll up the list of options or to find a higher value
<DOWN>	Press to scroll down the list of options or to find a lower value
<ENTER>	Press to activate a menu option or a selected value

Menu Map

Main Function	Programming Levels		Description	
Address	001–512		Sets the DMX starting address	
Run Mode	DMX	14CH	Selects DMX mode	
		08CH		
	Slave	Slave 1–4	Selects Slave mode 1, 2, 3, or 4	
	Auto		Selects Auto mode	
	Sound		Selects Sound-Active mode	
	IR		Selects infrared control	
	Manual	Pan	000–255	0 to 540°
		Pan Fine		Fine control of panning
		Tilt		0 to 270°
		Tilt Fine		Fine control of tilting
		P/T Speed		Pan/Tilt speed (fast to slow)
		Color		Selects color options
		Gobo		Selects Gobo options
		Gobo Rotate		Rotation effect with increasing speed
		Prism		Selects 3-facet prism
		Focus		Sets the focus
Dimmer		Sets dimmer value		
Shutter	Strobe effect with increasing speed			
P/T Macro	Selects pan/tilt movement macros			
Special Function		Selects control functions		
Setup	Pan Reverse	OFF	Normal pan operation	
		ON	Reverse pan operation	
	Tilt Reverse	OFF	Normal tilt operation	
		ON	Reverse tilt operation	
	Screen Reverse	OFF	Normal display	
		ON	Reverse display	
	Pan Angle	540	Selects the 540° pan angle range	
		360	Selects the 360° pan angle range	
		180	Selects the 180° pan angle range	
	Tilt Angle	270	Selects the 270° tilt angle range	
		180	Selects the 180° tilt angle range	
		090	Selects the 90° tilt angle range	
	Totem	OFF	Totem mode off	
Up		Selects upward pan and tilt range		
Down		Selects downward pan and tilt range		
Sensitivity	001–100	Sound sensitivity control		
Reset		Resets the product		
Factory Set		Loads factory defaults		
Sys Info	Ver: VX.X		Displays the software version	
	Running Mode: XXXXX		Displays the current running mode	
	DmxAddress: XXX		Displays the current DMX address	
	Temperature: XXX		Displays the LED temperature in Celsius	

Configuration (DMX)

Set the product in DMX mode to control with a DMX controller.

1. Connect the product to a suitable power outlet.
2. Connect a DMX cable from the DMX output of the DMX controller to the DMX input socket on the product.

Starting Address

When selecting a starting DMX address, always consider the number of DMX channels the selected DMX mode uses. If you choose a starting address that is too high, you could restrict the access to some of the product's channels.

The Intimidator Spot 355 IRC uses up to 14 DMX channels in its 14-channel DMX mode, which defines the highest configurable address to **499**.

If you are not familiar with the DMX protocol, download the DMX Primer from

To select the starting address, do the following:

1. Press **<MENU>**.
2. Use **<UP>** or **<DOWN>** to choose **Address**.
3. Press **<ENTER>**.
4. Use **<UP>** or **<DOWN>** to select the starting address.
5. Press **<ENTER>**.

DMX Personalities

The Intimidator Spot 355 IRC has two DMX personalities, a 14-channel personality and an 8-channel personality.

To choose which DMX personality to use, follow the steps below:

1. Press **<MENU>**.
2. Use **<UP>** or **<DOWN>** to choose **Run Mode**.
3. Press **<ENTER>**.
4. Use **<UP>** or **<DOWN>** to select **DMX**.
5. Press **<ENTER>**.
6. Use **<UP>** or **<DOWN>** until either **14CH** (to choose the 14-channel personality) or **08CH** (to choose the 8-channel personality) shows on the display.
7. Press **<ENTER>**.

5. DMX ASSIGNMENTS

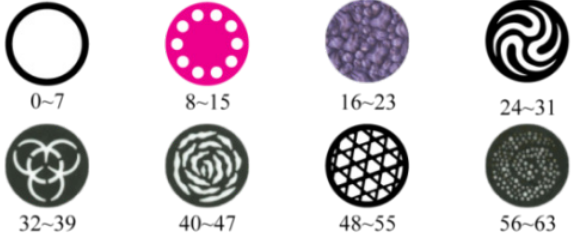
DMX14CH	Channel	Function	Value	Percent/Setting		
	1	Pan	000 ⇄ 255	0–540°		
	2	Fine Pan	000 ⇄ 255	Fine control of pan		
	3	Tilt	000 ⇄ 255	0–270°		
	4	Fine Tilt	000 ⇄ 255	Fine control of tilt		
	5	Speed	000 ⇄ 255	Pan/Tilt speed (fast to slow)		
	6	Color Wheel	000 ⇄ 006	White		
			007 ⇄ 013	Yellow		
			014 ⇄ 020	Pink		
			021 ⇄ 027	Green		
			028 ⇄ 034	Red		
			035 ⇄ 041	Light Blue		
			042 ⇄ 048	Kelly Green		
			049 ⇄ 055	Orange		
			056 ⇄ 063	Dark Blue		
			064 ⇄ 070	White + Yellow		
			071 ⇄ 077	Yellow + Pink		
			078 ⇄ 084	Pink + Green		
			085 ⇄ 091	Green + Red		
			092 ⇄ 098	Red + Light Blue		
			099 ⇄ 105	Light Blue + Kelly Green		
			106 ⇄ 112	Kelly Green + Orange		
			113 ⇄ 119	Orange + Dark Blue		
	121 ⇄ 127	Dark Blue + White				
	128 ⇄ 191	Color cycling rainbow with increasing speed				
	192 ⇄ 255	Reverse color cycling rainbow with increasing speed				
	7	Gobo Wheel				
			064 ⇄ 071	Gobo 7 shake (slow to fast)		
			072 ⇄ 079	Gobo 6 shake (slow to fast)		
			080 ⇄ 087	Gobo 5 shake (slow to fast)		
			088 ⇄ 095	Gobo 4 shake (slow to fast)		
			096 ⇄ 103	Gobo 3 shake (slow to fast)		
			104 ⇄ 111	Gobo 2 shake (slow to fast)		
			112 ⇄ 119	Gobo 1 shake (slow to fast)		
			120 ⇄ 127	Open		
			128 ⇄ 191	Cycle effect with increasing speed		
			192 ⇄ 255	Reverse cycle effect with increasing speed		
			8	Gobo Rotation	000 ⇄ 063	Index
					064 ⇄ 147	Rotate (slow to fast)
	148 ⇄ 231	Reverse rotate (slow to fast)				
	232 ⇄ 255	Bounce				









DMX14CH
(cont.)

Channel	Function	Value	Percent/Setting
9	Prism	000⇔007	Open
		008⇔012	Prism on
		013⇔130	Prism rotate (slow to fast)
		131⇔247	Reverse prism rotate (slow to fast)
		248⇔255	Prism effects
10	Focus	000⇔255	Motorized focus (big to small)
11	Dimmer	000⇔255	0–100%
12	Shutter	000⇔003	Closed
		004⇔007	Open
		008⇔076	Strobe (slow to fast)
		077⇔145	Pulse
		146⇔215	Random open and close
13	Control Function	216⇔255	Open
		000⇔007	No function
		008⇔015	Blackout pan/tilt movement
		016⇔023	Blackout color wheel movement
		024⇔031	Blackout gobo wheel movement
		032⇔039	Disable pan/tilt/color wheel movement blackout
		040⇔047	Disable pan/tilt/gobo wheel movement blackout
		048⇔055	Disable all movement blackout
		056⇔095	No function
		096⇔103	Reset pan
		104⇔111	Reset tilt
		112⇔119	Reset color wheel
		120⇔127	Reset gobo wheel
		128⇔135	Reset gobo rotation
136⇔143	Reset prism		
144⇔151	Reset focus		
152⇔159	Reset all channels		
160⇔255	No function		
14	Movement Macros	000⇔007	No function
		108⇔135	Automatic programs 1–8
		136⇔255	Sound-Active programs 1–8

DMX8CH

Channel	Function	Value	Percent/Setting
1	Pan	000⇔255	0–540°
2	Tilt	000⇔255	0–270°
3	Color Wheel	000⇔006	White
		007⇔013	Yellow
		014⇔020	Pink
		021⇔027	Green
		028⇔034	Red
		035⇔041	Light Blue
		042⇔048	Kelly Green
		049⇔055	Orange
		056⇔063	Dark Blue
		064⇔070	White + Yellow
		071⇔077	Yellow + Pink

DMX8CH (cont.)

Channel	Function	Value	Percent/Setting
3	Color Wheel	078 ⇄ 084	Pink + Green
		085 ⇄ 091	Green + Red
		092 ⇄ 098	Red + Light Blue
		099 ⇄ 105	Light Blue + Kelly Green
		106 ⇄ 112	Kelly Green + Orange
		113 ⇄ 119	Orange + Dark Blue
		121 ⇄ 127	Dark Blue + White
		128 ⇄ 191	Color cycling rainbow with increasing speed
192 ⇄ 255	Reverse color cycling rainbow with increasing speed		
4	Gobo Wheel		0-7
			8-15
			16-23
			24-31
			32-39
			40-47
			48-55
			56-63
		064 ⇄ 071	Gobo 7 shake (slow to fast)
		072 ⇄ 079	Gobo 6 shake (slow to fast)
		080 ⇄ 087	Gobo 5 shake (slow to fast)
		088 ⇄ 095	Gobo 4 shake (slow to fast)
		096 ⇄ 103	Gobo 3 shake (slow to fast)
104 ⇄ 111	Gobo 2 shake (slow to fast)		
112 ⇄ 119	Gobo 1 shake (slow to fast)		
120 ⇄ 127	Open		
128 ⇄ 191	Cycle effect with increasing speed		
192 ⇄ 255	Reverse cycle effect with increasing speed		
5	Gobo Rotation	000 ⇄ 063	Index
		064 ⇄ 147	Rotate (slow to fast)
		148 ⇄ 231	Reverse rotate (slow to fast)
		232 ⇄ 255	Bounce
6	Prism	000 ⇄ 007	Open
		008 ⇄ 012	Prism on
		013 ⇄ 130	Prism rotate (slow to fast)
		131 ⇄ 247	Reverse prism rotate (slow to fast)
248 ⇄ 255	Prism effects		
7	Focus	000 ⇄ 255	Motorized focus (big to small)
8	Shutter	000 ⇄ 003	Closed
		004 ⇄ 007	Open
		008 ⇄ 076	Strobe (slow to fast)
		077 ⇄ 145	Pulse
		146 ⇄ 215	Random open and close
216 ⇄ 255	Open		

Configuration (Standalone)

Set the product in one of the standalone modes to control without a DMX controller.

- Connect the product to power.



Never connect a product that is operating in any standalone mode (either Automatic or Sound-Active) to a DMX string connected to a DMX controller. Products in standalone mode may transmit DMX signals that could interfere with the DMX signals from the controller.

Sound-Active Mode

To enable the Sound-Active mode, do the following.

1. Press **<MENU>**.
2. Use **<UP>** or **<DOWN>** to choose **Run Mode**.
3. Press **<ENTER>**.
4. Use **<UP>** or **<DOWN>** to select **Sound**.
5. Press **<ENTER>**.



The product will only respond to low frequencies of music (bass and drums).

Sound Sensitivity

To set the sound sensitivity, do the following.

1. Press **<MENU>**.
2. Use **<UP>** or **<DOWN>** to choose **Setup**.
3. Press **<ENTER>**.
4. Use **<UP>** or **<DOWN>** to select **Sensitivity**.
5. Press **<ENTER>**.
6. Use **<UP>** or **<DOWN>** to select **001–100**, low to high.
7. Press **<ENTER>**.

Automatic Mode

To enable the Automatic mode, follow the instructions below:

1. Press **<MENU>**.
2. Use **<UP>** or **<DOWN>** to choose **Run Mode**.
3. Press **<ENTER>**.
4. Use **<UP>** or **<DOWN>** to select **Auto**.
5. Press **<ENTER>**.

Totem Mode

To activate the Totem Mode, do the following:

1. Press **<MENU>**.
2. Use **<UP>** or **<DOWN>** to choose **Setup**.
3. Press **<ENTER>**.
4. Use **<UP>** or **<DOWN>** to select **Totem Mode**.
5. Press **<ENTER>**.
6. Use **<UP>** or **<DOWN>** to choose **OFF**, **DOWN**, or **UP**.
7. Press **<ENTER>**.

Manual Test Mode To test or control any function of the Intimidator Spot 355 IRC through the LCD display menu, follow the instructions below:

1. Press **<MENU>**.
2. Use **<UP>** or **<DOWN>** to choose **Run Mode**.
3. Press **<ENTER>**.
4. Use **<UP>** or **<DOWN>** to select **Manual**.
5. Press **<ENTER>**.
6. Use **<UP>** or **<DOWN>** to select the function to test or control, from the options: **Pan, Pan Fine, Tilt, Tilt Fine, P/T Speed, Color, Gobo, Gobo Rotate, Prism, Focus, Dimmer, Shutter, Special Function, and P/T Macros**.
7. Press **<ENTER>**.
8. Use **<UP>** or **<DOWN>** to change the value of the selected function, from **000–255**.

NOTE: For information regarding what each value range does for each function, see the [DMX Assignments for 14CH Mode](#).

Pan/Tilt Orientation To select whether the Intimidator Spot 355 IRC will operate with normal panning or inverted panning, do the following.

1. Press **<MENU>**.
2. Use **<UP>** or **<DOWN>** to choose **Setup**.
3. Press **<ENTER>**.
4. Use **<UP>** or **<DOWN>** to select **Pan Reverse**.
5. Press **<ENTER>**.
6. Use **<UP>** or **<DOWN>** to select **ON** or **OFF**.
7. Press **<ENTER>**.

To select whether the Intimidator Spot 355 IRC will operate with normal tilting or inverted tilting, do the following:

1. Press **<MENU>**.
2. Use **<UP>** or **<DOWN>** to choose **Setup**.
3. Press **<ENTER>**.
4. Use **<UP>** or **<DOWN>** to select **Tilt Reverse**.
5. Press **<ENTER>**.
6. Use **<UP>** or **<DOWN>** to select **ON** or **OFF**.
7. Press **<ENTER>**.

Pan/Tilt Angle Range The user can select the range for the pan and tilt angles on the Intimidator Spot 355 IRC.

To select which pan angle range to use, do the following.

1. Press **<MENU>**.
2. Use **<UP>** or **<DOWN>** to choose **Setup**.
3. Press **<ENTER>**.
4. Use **<UP>** or **<DOWN>** to select **Pan Angle**.
5. Press **<ENTER>**.
6. Use **<UP>** or **<DOWN>** to select **540, 360, or 180**.
7. Press **<ENTER>**.

To select which tilt angle range to use, do the following.

1. Press **<MENU>**.
2. Use **<UP>** or **<DOWN>** to choose **Setup**.
3. Press **<ENTER>**.
4. Use **<UP>** or **<DOWN>** to select **Tilt Angle**.
5. Press **<ENTER>**.
6. Use **<UP>** or **<DOWN>** to select **270, 180, or 090**.
7. Press **<ENTER>**.

Display The user can flip the LED display for easy readability in any mounting situation.

To select the display orientation:

1. Press **<MENU>**.
2. Use **<UP>** or **<DOWN>** to choose **Setup**.
3. Press **<ENTER>**.
4. Use **<UP>** or **<DOWN>** to select **Screen Reverse**.
5. Press **<ENTER>**.
6. Use **<UP>** or **<DOWN>** to select **ON** or **OFF**.
7. Press **<ENTER>**.

Reset Options The **Reset** option will restart the product, but does not change any settings. Using the **Factory Set** option will clear out all customized settings and return the settings to the factory defaults To reset the software on the Intimidator Spot 355 IRC, do the following:

1. Press **<MENU>**.
2. Use **<UP>** or **<DOWN>** to choose **Setup**.
3. Press **<ENTER>**.
4. Use **<UP>** or **<DOWN>** to choose **Reset** or **Factory Set**.
5. Press **<ENTER>**.

System Information To view information about the Intimidator Spot 355 IRC:

1. Press **<MENU>**.
2. Use **<UP>** or **<DOWN>** to choose **Sys Info**.
3. Press **<ENTER>**. The current information about the product will show on the display.

Master/Slave Mode

The Master/Slave mode allows a single Intimidator Spot 355 IRC (the master) to control the actions of one or more Intimidator Spot 355 IRC products (the slaves) without the need of a DMX controller. The master will be set to operate in either Automatic or Sound-Active mode, while the slaves will be set to operate in Slave mode. Once set and connected, the slaves will operate in unison with the master.

Configure the products as indicated below.

Slaves:

1. Press **<MENU>**.
2. Use **<UP>** or **<DOWN>** to choose **Run Mode**.
3. Press **<ENTER>**.
4. Use **<UP>** or **<DOWN>** to select **Slave**.
5. Press **<ENTER>**.
6. Use **<UP>** or **<DOWN>** to select **Slave1**, **Slave2**, **Slave3**, or **Slave4**.
 - Select **Slave1** for 100% synchronized actions.
 - Select **Slave2**, **Slave3**, or **Slave4** for a delayed show with all heads in the same direction but with a delay creating a wave effect.
7. Press **<ENTER>**.
8. Connect the DMX input of the first slave product to the DMX output of the master.
9. Connect the DMX input of the subsequent slaves to the DMX output of the previous slave.
10. Finish setting and connecting all the slaves.

Master:

1. Set the master to operate in either Automatic or Sound-Active mode.
2. Make the master the first product in the DMX daisy chain.

When including Intimidator Spot LED 350 products in Master/Slave configuration with Intimidator Spot 355 IRC products, you must observe the following:



- **When the Intimidator Spot LED 350 is the master and the Intimidator Spot 355 IRC is connected as a slave, the Intimidator Spot 355 IRC must be set to DMX mode with a starting address of 001. DO NOT set the Intimidator Spot 355 IRC in Slave mode when an Intimidator Spot LED 350 is the master.**

- **The Intimidator Spot 355 IRC will not operate as the master to an Intimidator Spot LED 350 connected as a slave.**



- **Configure all the slaves before connecting the master to the DMX daisy chain.**
- **Never connect a DMX controller to a DMX string configured for Master/Slave operation because the controller may interfere with the signals from the master.**
- **Do not connect more than 31 slave units to the master.**

IR Mode

IR mode allows the product to be controlled with an infrared remote controller. The IRC-6 can remotely set the product to various modes; adjust the color, speed and sensitivity; and set the strobe.

To set the product to IR mode, do the following:

1. Make sure the product is plugged into a power source and not connected to a DMX cable.
2. Press **<MENU>**.
3. Use **<UP>** or **<DOWN>** to choose **Run Mode**.
4. Press **<ENTER>**.
5. Use **<UP>** or **<DOWN>** to choose **IR**.
6. Press **<ENTER>** and the IR indicator on the front of the Intimidator Spot 355Z IRC lights up.

IRC-6 Operation

Be sure the IRC-6 remote is pointing directly at the product and there is nothing in between the remote and the product.

Some of the buttons on the remote work differently than what is indicated on their labels. For example:

- **<MANUAL>** changes the Gobo pattern.
- **<FADE>** changes the color.
- **<R>**, **<G>**, ****, **<A>** and **<W>** control other manual functions.

Please read the next section carefully.

The list below describes which features each button controls.

- **<BLACKOUT>** - Turns LED on and off.
- **<AUTO>** - Activates Auto mode. Use the **<+>** and **<->** buttons to cycle through Auto modes.
- **<SOUND>** - Activates Sound mode.
- **<STROBE>** - Activates the strobe. Use the **<+>** and **<->** buttons to cycle through strobe speeds.
- **<SPEED>** - Adjusts the movement speed. Use the **<+>** and **<->** buttons to cycle through movement speeds.
- **<SENSITIVITY>** - Adjusts sound sensitivity. Use the **<+>** and **<->** buttons to cycle through sound sensitivity levels.
- **<%>** - Adjusts the brightness of the LEDs. Use the **<+>** and **<->** buttons to increase or decrease the brightness of the LEDs.
- **<MANUAL>** - Changes the Gobo pattern. Use the **<+>** and **<->** buttons to scroll through the GOBO options.
- **<FADE>** Changes the color. Use the **<+>** and **<->** buttons to scroll through the color options.
- **<R>** - Activates color wheel rotation control. Use the **<+>** and **<->** buttons to increase or decrease rotation speed.
- **<G>** - Activates Gobo wheel rotation control. Use the **<+>** and **<->** buttons to increase or decrease rotation speed.
- **** - Activates color and Gobo auto mode, independent from movement.
- **<A>** - Activates pan and tilt control. Press **<A>** to toggle pan and tilt, and use the **<+>** and **<->** buttons to increase or decrease pan or tilt values.
- **<W>** - Activates prism control. Use the **<+>** and **<->** buttons to set prism value, **0–15** for off, **16–255** for on.
- **<+>** - Increases values for controls as described above.
- **<->** - Decreases values for controls as described above.
- **<0>–<9>** - Activates specific Auto modes. Can be used as a shortcut for the combination of the **<AUTO>** button and the **<+>** and **<->** buttons.
- **<UV>** or **<P>** - Adjusts the focus.

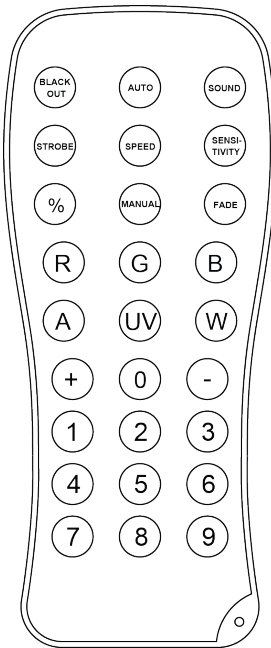

Zero Adjust Mode

The Intimidator Spot 355 IRC contains a passcode-protected mode that allows you to calibrate and adjust several of the product's operating parameters.

To access this mode, do the following:

1. Press and hold **<MENU>** for at least 10 seconds.
2. Use **<UP>** and **<DOWN>** to enter the passcode: **2323**.
3. Press **<ENTER>**.

In this mode there are several options for adjustment:

Parameter	Default	Description
PAN	128	Manually adjust the starting pan angle
TILT	095	Manually adjust the starting tilt angle
GOBO	120	Manually adjust the gobo wheel starting position
GOBOR	128	Manually adjust the gobo starting position
COLOR	128	Manually adjust the color wheel starting position
PRISM	128	Manually adjust the prism starting position
FOCUS	128	Manually adjust the focus starting position
LED	000	Manually adjust the starting brightness of the LED

Changing Gobos

To change the gobos in the Intimidator Spot 355 IRC, do not remove the gobo wheel. Simply:

1. Disconnect product from power outlet.
2. Place the product on a flat, level surface with the front facing up.
3. Access the gobo plate by removing the cover on the moving head. By hand, gently push downward on the cover, in the direction of the debossed arrowhead on the cover.
4. Rotate the gobo wheel until the gobo that needs replacing is accessible.
5. Separate the gobo holder assembly away from the gobo wheel by pushing it forward and up. Be careful not to push the gobo out of the gobo plate.
6. Extract the gobo holder by pulling it backwards out of the product.
7. On a flat surface, remove the expansion ring that holds the gobo in place and remove the gobo from the gobo plate.
8. Insert a new gobo and hold it in place with the expansion ring.
9. To re-insert the new gobos, slide the tip of the gobo holder under the pressure plate near the center of the gobo wheel.
10. Push the gobo holder assembly inwards. DO NOT force the gobo holder into the gobo wheel slot. Slightly move the holder from side-to-side if needed to get it to seat properly. If correctly installed, the bottom of the holder will be flush with the gobo wheel.
11. Push cover back into position.

Gobo Replacement Diagram

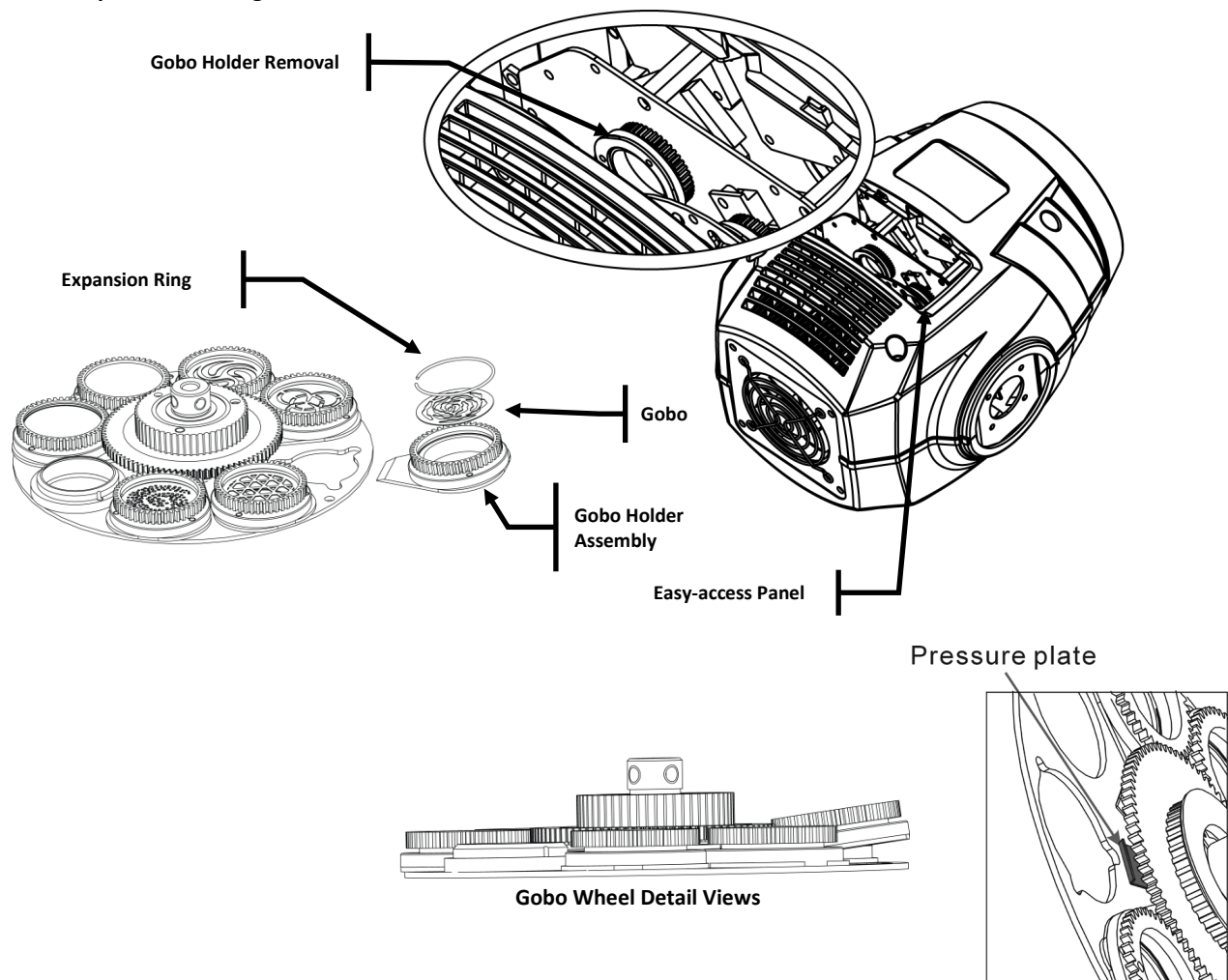

6. TECHNICAL INFORMATION

Product Maintenance

Dust build up reduces light output performance and can cause overheating. This can lead to reduction of the light source's life. To maintain optimum performance and minimize wear, you should clean your lighting products at least twice a month. However, be aware that usage and environmental conditions could be contributing factors to increase the cleaning frequency.

To clean the product, follow the instructions below:

1. Unplug the product from power.
2. Wait until the product is at room temperature.
3. Use a vacuum (or dry compressed air) and a soft brush to remove dust collected on the external surface/vents.
4. Clean all glass/transparent surfaces with a mild soap solution, ammonia-free glass cleaner, or isopropyl alcohol.
5. Apply the solution directly to a soft, lint free cotton cloth or a lens cleaning tissue.
6. Softly drag any dirt or grime to the outside of the glass/transparent surface.
7. Gently polish the glass/transparent surfaces until they are free of haze and lint.



Always dry the glass/transparent surfaces carefully after cleaning them.



Do not spin the cooling fans using compressed air because you could damage them.

7. TECHNICAL SPECIFICATIONS

Dimensions and Weight	Length	Width	Height	Weight
	10.6 in (268 mm)	13.4 in (340 mm)	15.4 in (392 mm)	24.6 lb (11.2 kg)

Note: Dimensions in inches rounded to the nearest decimal digit.

Power	Power Supply Type	Range	Voltage Selection
	Switching (internal)	100 to 240 VAC, 50/60 Hz	Auto-ranging
Parameter	120 V, 60 Hz	230 V, 50 Hz	
	Consumption	186 W	179 W
	Operating	1.7 A	1 A
	Power linking current (units)	8 A (4 units)	8 A (7 units)
Fuse	F 5 A, 230 V	F 5 A, 250 V	
Power I/O	US/Worldwide	UK/Europe	
	Power input connector	IEC	IEC
	Power output connector	Edison	IEC
	Power Cord plug	Edison (US)	Local plug

Light Source	Type	Power	Lifespan
	LED	90 W	50,000 hours
Color	Quantity	Current	
	White	1	24.2 A

Photometrics	Parameter		
	Illuminance	21,810 lux @ 2 m	
	Beam angle	15°	
	Strobe Rate	0 to 15.2 Hz	
	Pan and Tilt	540° Pan	240° Tilt
	Pan/Tilt Ranges	540°, 360°, 180° Pan	240°, 180°, 90° Tilt
	Gobo Size	24 mm outside 20 mm image 1.1 mm maximum thickness	

Thermal	Maximum External Temp.	Cooling System
	104 °F (40 °C)	Fan-cooled

DMX	I/O Connectors	Connector Type	Channel Range
	3-pin XLR	Sockets	8 or 14

Ordering	Product Name	Item Code	UPC Number
	(Black) Intimidator Spot 355 IRC	08011153	781462215019
	(White) Intimidator Spot 355 IRC	08011213	781462215613

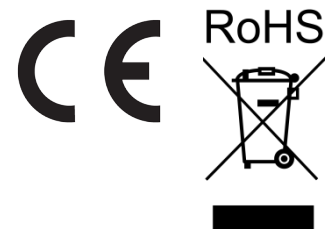

To return a product or request support:

- In the U.S., contact Chauvet World Headquarters (See [Contact Us](#)).
- In the UK or Ireland, contact Chauvet Europe Ltd. (See [Contact Us](#)).
- In Mexico, contact Chauvet Mexico. (See [Contact Us](#)).
- In Benelux, contact Chauvet Europe BVBA. (See [Contact Us](#)).
- In any other country, DO NOT contact Chauvet. Instead, contact your lighting distributor.



Outside the U.S., UK, Ireland, Mexico, or Benelux, contact your distributor and follow their instructions on how to return Chauvet products to them. Visit our website for contact details.

Returns

Call the corresponding Chauvet Technical Support office and request a Return Merchandise Authorization (RMA) number before shipping the product. Be prepared to provide the model number, serial number, and a brief description of the cause for the return.

You must send the merchandise prepaid, in its original box, and with its original packing and accessories. Chauvet will not issue call tags.

Clearly label the package with the RMA number. Chauvet will refuse any product returned without an RMA number.



Write the RMA number on a properly affixed label. DO NOT write the RMA number directly on the box.

Before sending the product, clearly write the following information on a piece of paper and place it inside the box:

- Your name
- Your address
- Your phone number
- RMA number
- A brief description of the problem

Be sure to pack the product properly. Any shipping damage resulting from inadequate packaging will be your responsibility. FedEx packing or double-boxing are recommended.



Chauvet reserves the right to use its own discretion to repair or replace returned product(s).

CONTACT US

USA WORLD HEADQUARTERS

General Information

Address: 5200 NW 108th Avenue
Sunrise, FL 33351
Voice: (954) 577-4455
Fax: (954) 929-5560
Toll free: (800) 762-1084

CHAUVET EUROPE

General Information

Address: Stokstraat 18
9770 Kruishoutem
Belgium

Voice: +32 9 388 93 97

General Information

Address: Unit 1C
Brookhill Road Industrial Estate
Pinxton, Nottingham, UK
NG16 6NT

Voice: +44 (0)1773 511115
Fax: +44 (0)1773 511110

MEXICO

General Information

Address: Av. Santa Ana 30
Parque Industrial Lerma
Lerma, Mexico C.P. 52000
Voice: +52 (728) 285-5000

Outside the U.S., United Kingdom, Ireland, Mexico, or Benelux contact your dealer. Follow their instructions to request support or to return a product. Visit our website for contact details.