

ATMOS HAZE 1400



CONTENTS

Warning	1
Important safeguards	3
Caution	4
Particular warning	4
Important	4
Please note:	5
ATMOS HAZE 1400 Functions Description ..	5
Getting ready	6
Set Up	7
DMX Connector Pin Assignment Functions ..	7
of the buttons	8
Operation	9
DMX Chart	11
Troubleshooting	16
Power Connected but No Smoke is Emitted ..	17
Power Connected, Fog Blasts not Smooth	17
Other Abnormal Situations:	17
Maintenance	18
Product Specification	18
.....	21

If the supply cord is damaged, it must be replaced by the manufacturer, its service agent or similarly qualified persons in order to avoid a hazard.

Instructional icons



Read the manual



Indoor use only



This symbol indicating separate collection for electrical and electronic equipment



Warning: situations that could cause injury to yourself or others



Caution: situations that could cause damage to your machine or other equipment



Note: notes, usage tips, or additional information

Thank you for selecting our Atmos serials DMX Haze machine, you already own the high-tech, professional DMX Haze! Better read the manual thoroughly before operation, follow instruction will help you have a smooth handling with Atmos serials DMX Haze machine to achieve the most satisfactory Haze effect, it will also assist unit to further prolong life time as a whole.



Warning!

Like all electronic products, ATMOS HAZE 1400 must be used with safety precautions in mind.

Fill enough fog fluid before plugging in, empty fluid tank when not in use or moving.

- Use only appropriate, grounded electric power supply for your unit. See your product specification label for appropriate power supply. This appliance must be earthed.
- Disconnect from electric mains power supply when not in use, when filling the **HAZE** fluid tank, or when changing a fuse. Keep unit dry. If moisture or liquids enter the Haze machine case, immediately disconnect power supply. Contact a service technician to determine safety for use.
- Keep machine in flat position, never put it in tilted place.
- Before moving machine, always drain fog fluid into the tank and tighten the tank cap securely to avoid spilling.

- Without user-serviceable parts in the package, please contact your local agent or qualified technician for servicing.
- Without changeable structure by non-qualified user, please do not open the up cover or have any change at will, otherwise, it may cause accident!
- Haze machine is for adult use. Keep out of reach of children. Never leave the unit running unattended.
- Haze machine nozzle gets hot over 200 degrees (centigrade) during use. Don't touch! Maintain a safe distance over 100CM. Never aim the nozzle directly at people.
- Keep case closed while operating. Put Haze machine in drafty place. Do not insert objects into air vents. Allow 20cm space or above around the machine for proper ventilation.
- Keep Haze machine away from flames and flammable items. Never aim the nozzle at open flames or sparks. Use only high quality **water-based Haze fluid**. Never put flammable substances into the tank.
- Machine must cool down before cleaning, servicing or storing.
- Never put any flammable material (lipid, gas, perfume etc.) into the tank, read the user manual thoroughly before operation.
- Better use our high quality water-based fog fluid, random use with other Haze fluid may jam the pipe, or even erode the components inside.

- Keep sufficient fluid in tank. Operating the unit without sufficient fluid, the pump will slowdown the power.
- If any abnormal running occurs, stop it immediately, empty the fluid, and bring the done up unit (recommend original box) to your agent or dealer for servicing. Make sure all fluid is empty from the tank before moving or shipping.
- Never drink fog fluid. If ingested, call a doctor immediately. If fluid contacts eyes or skin, rinse skin thoroughly with water.
- Read user manual instructions thoroughly before operating. Follow the instruction. Never remove warning or informative labels from the unit.

Important Safeguards

- Read all instruction
- Products for indoor use only. Keep away from liquids. Never operate in rain or in damp conditions.
- Unit must be grounded.
- Don not open unit, risk of electric shock.
- Keep machine in flat position, never put it in tilted place.
- Do not immerse in any liquid
- Save these instructions.



Caution!

There are no user serviceable parts inside this unit. Do not attempt any repairs yourself, doing so will void your manufacturer's warranty. In the unlikely event your unit may require service please contact your local dealer.



Particular Warning :

Please install the product correctly according to the instruction of the user manual. To avoid any accident, it is not allowed to install the product with any way not instructed on the user manual. If accident happens because users do not install the product according to the instruction of the user manual, the manufacturer will not take any responsibility.



Please note:

Specifications and improvements in the design of this unit and this manual are subject to change without any prior written notice.

Important

The wires in this mains lead are colored in accordance with the following code.



EU

Green and Yellow – Earthed (E)

Blue – Neutral (N)

Brown – Live (L)

Warning: This appliance must be earthed.

USA

Green and Yellow – Earthed (E)

White – Neutral (N)

Black – Live (L)

Warning: This appliance must be earthed.

Figure1 ATMOS HAZE 1400 Functions



- A.** Hanging Bracket
- B.** Unique Anti-Spill Tank
- C.** Quick Connector
- D.** Blue LCD screen
- E.** 6 Buttons

- F.** DMX 5 pin XLR Output
- G.** DMX 5 pin XLR Input
- H.** DMX 3 pin XLR Output
- I.** DMX 3 pin XLR Input
- J.** Fuse Holder or NFB
- K.** Electric Power Input
- L.** Fog Output Nozzle
- M.** Sponge
- N.** Cushion
- O.** Fan Net

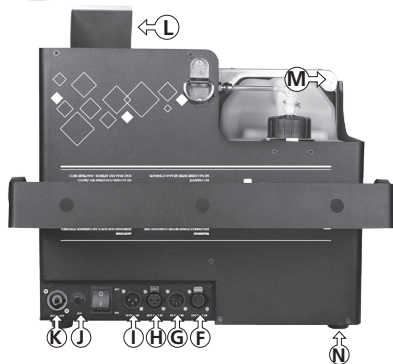

Description

- Smooth and stable smoke output control from 5-100%. In accordance with different wind power, the smoke can be adjusted from minimum to 100%. Suitable for operation in any locations.
- 5-100% fan speed adjustment. Quiet and smooth fan let the smoke disperse unknowingly. 100% high fan speed let the smoke be thin and even, and expand more quickly throughout the location.
- Primary heating up takes very short time, only about 60 seconds, shorter than general Haze machines.
- The machine can be installed for up spray or forward spray.
- Unique design of 5.6 liter liquid tank let have no worry of oil leaking when being operated up spray or side spray. Quick connector makes replacement direct and easier when performance is ongoing.
- DMX on board, 3 DMX modes for choice; 1CH, 2CH, 4CH, operate by any additional DMX controller.
- Multi-function operation control. Built-In timer control, manual fogging control and continuous fogging control.
- Heavy-duty. Able to keep working long time.
- Self-cleaning function: The machine design of machine stops working after a delay of 30 seconds, automatically clear the tubing of the remaining liquid.
- Design of expediting liquid supply: When low smoke output, it takes more time for supplying the liquid for the first time. The function of manual fogging is suggested to be used for expediting liquid supply and save time.
- Easy understanding LCD display and intelligent design of software control.
- Rugged high-quality shape designed with strong bracket. Liquid tank designed for quick fixing and with protection against getting loosen during transportation. All details are required.

Getting Ready

All products are thoroughly tested at the factory and shipped in perfect condition. If damage has occurred during shipping, or if components are missing, please contact your local dealer immediately.

Your package should include:

1. One Atmos 1400 DMX Haze
2. One Power Cord
3. One product user manual

Set Up

1. Open the shipping carton and carefully remove the unit from the shipping carton;
2. Be sure to remove packing material from around the Haze machine, especially near the nozzle;
3. Set the Haze machine on a dry, flat surface;
4. Connect the quick connector with the liquid tank cap (Figure 1-C). Be sure of well connection. Use definitely water based liquid of good quality;
5. Plug mains power cord from the Haze machine into appropriate power supply socket. Wait about 60 seconds for heating element to heat up;
6. Use LCD display for operating control, or connect DMX controller for setting;
7. Moving the machine during operation could probably get air entered into the liquid pipe and affect smoothness of fog blasts. If this happened, use "Manual" function to force the machine to fog for a moment. Until the air is dispersed from the pipe, the machine will recover its normal fogging.

DMX Connector Pin Assignment

The machine provides a 3- or 5-pin XLR connector for DMX connection. The diagram below indicates pin assignment information.

5 pin XLR

XLR Male Socket

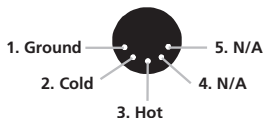

XLR Female Socket

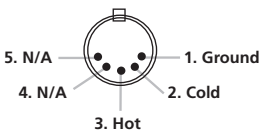

XLR Pin Configuration

- Pin 1= Ground
- Pin 2= Data Compliment
(negative)
- Pin 3= Data True (positive)
- Pin 4= No use
- Pin 5= No use

3 pin XLR

XLR Male Socket

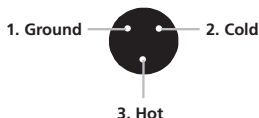

XLR Female Socket

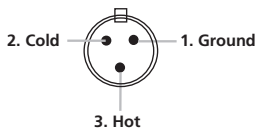

XLR Pin Configuration

- Pin 1= Ground
- Pin 2= Data Compliment
(negative)
- Pin 3= Data True (positive)

Functions of the buttons

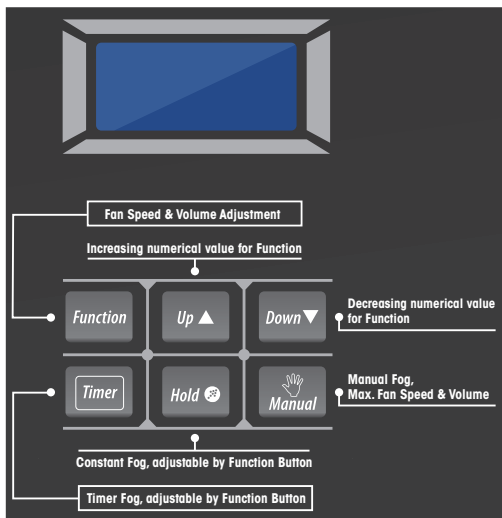

FUNCTION:Function switching button; then have the numerical value changed by using UP and DOWN buttons.

DMX Mode: DMX mode selection. Single channel, 2 channel and 4 channel mode can be selected.

DMX Set: Setting of DMX address; Range of address value: address=001~512. Press "UP" or "Down" 1.5 seconds can change value continuously and fast, pressed UP/DOWN at the same time, value back to 1.

Vol xxx: Setting output of timing fogging and continuous Fogging(Volume=5~100%).

Fan xxx: Setting fan speed of timing fogging and Continuous Fogging (Fan=5~100%).

DUR. xxx: Setting duration of timing fogging(Duration=3~250s).

INT. xxx: Setting interval of timing fogging(Interval=5~250s).

UP: Button for increasing numerical value

DOWN: Button for decreasing numerical value

TIMER: Starting button of timing fogging.

HOLD: Starting button of continuous fogging.

MANUAL: Starting button of manual fogging. Press "Manual" (without releasing), maximum output and maximum fan speed fogging. Release "Manual" to recover previous status. This function can be started forcedly under any status.



- Self-cleaning function: The machine design of machine stops working after a delay of 30 seconds, automatically clear the tubing of the remaining liquid.
- If wanting to expedite liquid supply when powered on the machine, using function of manual fogging can help.
- Set values are automatically saved.
- If fluid is run out, full the tank with fluid and press "Manual" to reset.

Operation

1. Plug mains power cord from the Haze machine into appropriate power supply socket;

2.

Version: 1.0

 Primary power on;

3.

Warming Up.....

 2 seconds after, switches to working status:
heating up;

4. Wait about 60 seconds for heating element to heat up;

5.

DMX set Addr- xxx

 After heating up, displays the previous functions list before the last power off; The picture shows the new machine default state;

6. After the heating up is complete, Please do follow the required operating modes;

****REMARK****

To reduce the possibility of that the wind mouth gets humid, the software will detect the wind value and the fog value, and do proper adjustment. Under display control mode (timing fogging, continuous fogging and manual fogging) or DMX control mode : when fog value is adjusted to 100%, the software will adjust wind value (even it is set at 5%) to 30% automatically; when wind value is adjusted to 5%, the software will reduce fog value to 50% automatically. This will prevent the wind mouth from getting humid because of too small wind but too much fog.

*Fog value = Volume, wind value = Fan

Timing Fogging Operation

- | |
|----------------------|
| DUR. xxx
INT. xxx |
|----------------------|

Press "Timer" to enter timing fogging status;
- Under this status, press "Function" to get into timing setting menu, please note timing fogging stops at the same moment;
- | |
|--------------------------|
| --> Dura xxx
Intv xxx |
|--------------------------|

Press "Up" or "Down" to adjust the value of continuous time (3s – 250s);
- Press again "Function" to switch to adjust the value of Interval, please note timing fogging still stops at the same moment;
- | |
|--------------------------|
| Dura xxx
--> Intv xxx |
|--------------------------|

Press "Up" or "Down" to adjust time value of interval(5s – 250s). Press "FUNCTION" to move the arrow up or down;
- | |
|----------------------|
| DUR. xxx
INT. xxx |
|----------------------|

After setting the timing, press "Timer" to re-start timing fogging;
- | |
|--------------------|
| (Stop)
Cleaning |
|--------------------|

Press again "Timer" to stop Timing fogging. Please note the machine design of machine stops working after a delay of 30 seconds;automatically clear the tubing of the remaining liquid
- | |
|----------------------|
| DMX set
Addr- xxx |
|----------------------|

After the Self-cleaning process is complete, return to the previous picture status.



-
- If wanting to expedite liquid supply when powered on the machine, using function of manual fogging can help.
 - When executing timing fogging, can press "Hold" to switch to continuous fogging directly.
 - When executing timing fogging, can press "Manual" to switch to Manual fogging directly, this function can be started forcedly under any status.
-

Continuous Fogging Operation

- | |
|------------------------|
| --> Vol xxx
Fan xxx |
|------------------------|

Press "Hold" to enter continuous fogging status, please note continuous fogging starts at the same moment;
- | |
|------------------------|
| --> Vol xxx
Fan xxx |
|------------------------|

Press "Up" or "Down" to adjust smoke volume value(5 – 100%);
- Press "Function" to switch to adjust the speed of fan, please note continuous fogging still works at the same moment;
- | |
|------------------------|
| Vol xxx
--> Fan xxx |
|------------------------|

Press "Up" or "Down" to adjust fan speed (5 – 100%)Press "FUNCTION" to move the arrow up or down;
- | |
|--------------------|
| (Stop)
Cleaning |
|--------------------|

Press again "Hold" to stop Continuous fogging. Please note the machine design of machine stops working after a delay of 30 seconds; automatically clear the tubing of the remaining liquid.
- | |
|----------------------|
| DMX set
Addr- xxx |
|----------------------|

After the Self-cleaning process is complete, return to the previous picture status.



-
- If wanting to expedite liquid supply when powered on the machine, using function of manual fogging can help.
 - When executing continuous fogging, can press "Timer" to switch to Timing fogging directly.
 - When executing timing fogging, can press "Manual" to switch to Manual fogging directly, this function can be started forcedly under any status.
-

Manual Fogging Operation.....

1.

Manual V100 F100

 As long as heating is completed, under any status, press " Manual" (without releasing), the machine with maximum output and maximum fan speed fogging;
2. Release "Manual" to recover previous status.

Other Operation Tips.....

- | |
|----------------------|
| DMX set
Addr- xxx |
|----------------------|

 In previous status, it is allowed to press "Function" to enter the selection of functions list directly;
- | |
|------------------|
| *Hold
TimeSet |
|------------------|

 Press "Up" or "Down" to move "*" up or down, press again "Function" to enter the function selected by "*", and setting the menu like previous timing fogging mode or continuous fogging mode;
- | |
|----------------------|
| DMX set
Addr- xxx |
|----------------------|

 There is no operator action for two seconds, then automatically revert to the previous status;

DMX Control Operation

1. Connect the DMX 512 controller cable to the input socket (G or I of figure 1) of the fog machine unit. Make sure the signal cable polarity is correct. When DMX socket receives effective DMX signals, the machine enter DMX control mode automatically.
2. There are 3 DMX modes for choice; 1CH, 2CH, & 4CH, please choose the mode by Function.
3.

1ch.Axxx VxxxFxxx

 Upper display DMX mode and DMX address value, press "Up" or "Down" button to set the DMX address;

4.

1ch.Axxx VxxxFxxx

 Below display current DMX controlled smoke volume value and fan speed;
 5.

2ch.Axxx VxxxFxxx

 Or please press "Function" to switch to 2CH mode to do appropriate DMX address setting;
 6.

4ch.Axxx VxxxFxxx

 Or please press "Function" to switch to 4CH mode to do appropriate DMX address setting;
 7.

VxxxFxxx DxxxIxxx

 In 4CH mode, there is no operator action for two seconds, then automatically revert to the previous status. Upper display current DMX controlled volume value and fan speed, below display current DMX controlled duration and interval value;
 8.

4ch.Axxx VxxxFxxx

 Press "Function" again to revert to 4ch mode and DMX address setting;
9. Please switch the DMX mode 1ch, 2ch or 4ch by Function.
10. If desired, connect another Haze machine: Plug one end of another signal cable in to the output socket (F or H of figure 1) on the back of the first ATMOS; plug the other end of the signal cable to the input socket (G or I of figure 1) on the back of the second ATMOS. Follow the same procedure to link more fog machine, if desired; whole link is daisy chain.
11. Down. Refer to DMX channel chart in Figure 2 make related settings. Now start operating with DMX console.



-
- If wanting to expedite liquid supply when powered on the machine, using function of manual fogging can help.
 - Upon receiving DMX signal, except Manual fogging function, all built-in functions are invalid.
 - DMX signals dismissed, machine recovers display control mode, and built-in functions are recovered.
-

Figure 2 DMX Chart

1 CH

CH1	
5-255	Volume 5%-100% Fan 100%
0-4	Volume 0% Fan 5%

2 CH

CH1		CH2	
Volume		Fan	
5-255	5%-100%	16-255	6%-100%
0-4	Off	0-15	5%

4 CH

CH1	CH2	CH3	CH4
Volume	Fan	Duration	Interval
5-255 5%-100%	16-255 6%-100%	8-255 3-250(s)	10-255 5-250(s)
0-4 Off	0-15 5%	0-7 3(s)	0-9 0(s)

**Interval =0 means constant fog.

Troubleshooting

This troubleshooting guide is meant to help solve simple problems. If a problem occurs, carry out the steps below in sequence until a solution is found. Once the unit operates properly, do not carry out following steps. If the problem persists, refer servicing to a qualified technician.

Power Connected but No Smoke is Emitted:

1. Check the power supply. Plug the unit into grounded electric power supply socket with proper voltage.
2. Disconnect fog machine from electric power supply. Replace fuse with one of the same type.
3. Keep sufficient fluid in tank.
4. Check if pump is working (with fluid flow or not).
5. Check if the heater is heating (touch the panel to see if it is warming).
6. Check your controller if in correct connection.
7. Check your DMX address setting.

Power Connected, Fog Blasts not Smooth:

Moving the machine during operation could probably get air entered into the liquid pipe and affect smoothness of fog blasts. If this happened, use "Manual" function to force the machine to fog for a moment. Until the air is dispersed from the pipe, the machine will recover its normal fogging.

Should there be any low fog emitted, running noisily or hindered fogging, pull out the plug immediately. Check if string enough fluid, if the pipe connected to the tank is clean, if there's air inside the pipe, if the liquid flows, if not, plug-in again; still persists abnormal running, and If causation is unclear, stop running to avoid any damage, shut down to cool it, and bring unit to your local agent or appointed service place for inspection, prohibit any dismantlement by yourself.

Other Abnormal Situations:

Heater
Overheat

Flashing and showing this status, means heater is too hot or thermos sensor is cut;

No
Heating

Flashing and showing this status, means unable heating;

No
Fluid

Flashing and showing this status, means fluid runs out or pumping no fluid; at this moment, speed of the fan will reduce to minimum, and pump will stop working.



- If fluid is run out, full the tank with fluid and press “Manual” to reset.

Maintenance

Before doing maintenance, please make sure that the power is cut, the power cord is unplugged, and the machine itself has cooled down.

The maintenance must be done by qualified person.

1. The fluid is not allowed to get dirty. Be sure to always clean or replace the caps on the tank (Replace the caps on the tank directly. This kit includes quick connector, cap, pipe and filter) and tight the cover of the Haze machine tank immediately after filling.

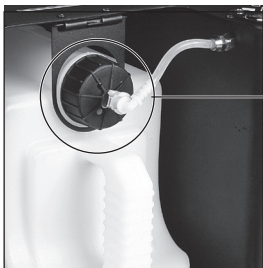

2. Prolonged use, the nozzle may be clogging by impurities, periodically use tools to clean the nozzles, keep the nozzle unobstructed.

3. Prolonged use, flight case side air filter can accumulate dust, periodically remove the flight case side cover and remove the air filter to do the cleaning, after cleaning, be sure to dry the air filter after replacing the flight case again.

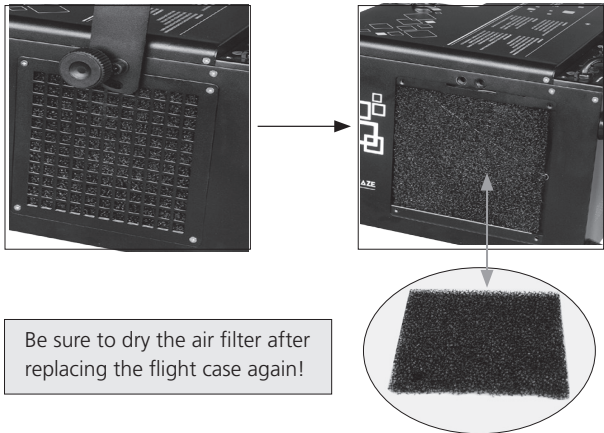

4. Prolonged use, sponge inside the vent may accumulate oil, periodically cleaned out or replaced with a new sponge.

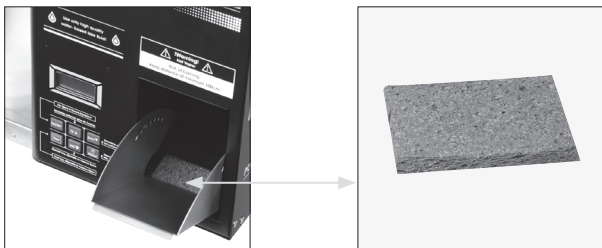

5. Periodically check the connections among the oil tube, the pump and the heater to see if there's oil leaking. If positive, lock tight the connections carefully with proper tool.
6. PC board should be kept from being dirtied with oil. In case this happened, dismantle carefully the PCB, and have it brushed clean both sides with dilute alcohol. Leave it dry itself, then install it back. Make sure all wires are well connected.
7. Clean the metal cover with dry cloth.

Product Specifications

Name	Atmos DMX Haze machine
Item No.	ATMOS HAZE1400
Housing configuration	No flight case, black iron casing
Heater Power	1400W
Consumption	1500W
DMX512 CH.	1CH, 2CH, or 4CH
Built-in Function	<ul style="list-style-type: none"> • Timing Fogging • Continuous Fogging • Manual Fogging
Fuse (120V)	NFB 16A
Fuse (230V,240V)	NFB 10A
Display	Blue LCD Screen
Tank (liters)	5.6L
Fog Output (cu.ft/min)	15000
Warm Up time(seconds)	60
Fluid Consumption (ml/min)	Max.output 16ml/min; Min.output 0.45ml/min
Date Connection	3P or 5P XLR
Low Fluid Shutdown	Yes
Bracket	Yes
Voltage	120V/60Hz; 230V,240V/50Hz
Dimensions (LxWxH w/o bracket)	394 x 434 x 253mm
Weight (kg)	10.6

* Voltage is preset at the factory and may not be changed.

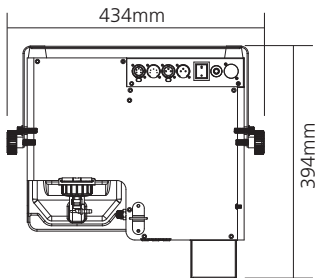
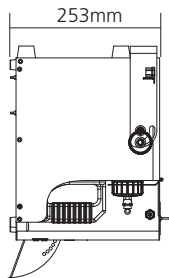

ATMOS

Save this instruction properly
All the information is subject to change without prior notice