

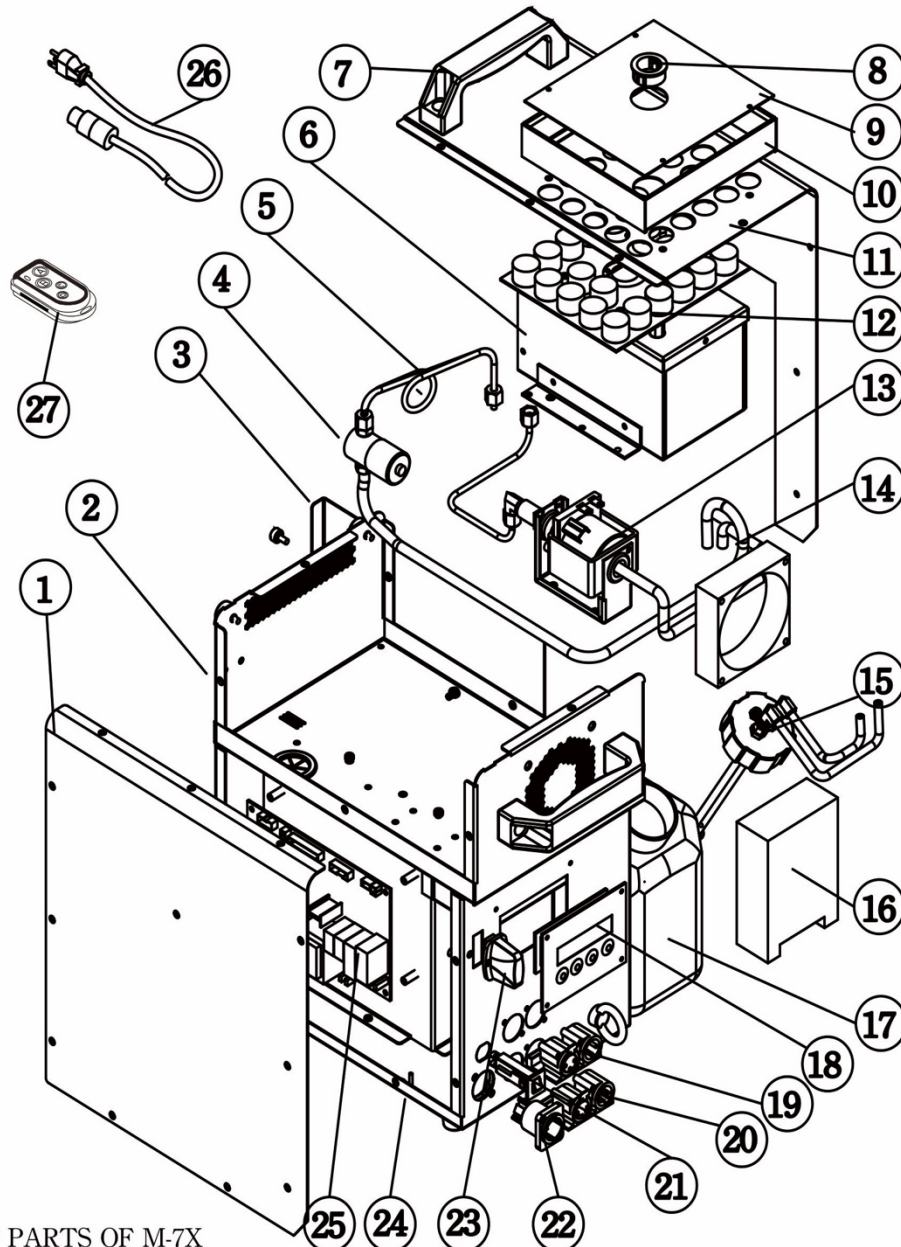

M-7X
Stage Fog Machine
User Manual



English • 中文



SPARE PARTS OF M-7X

① M007XLH10	Steel Case/Left Cover	⑮ M-7X-TKC(TKC5A00BA)	Tank Cover
② M007X0110	Steel Case/UP Base	⑯ M-7X-POW	LED Power Supply
③ M007A0301-M7X	Steel Case/Tank Cover	⑰ M-7X-TK(TK1024000)	Tank Cover
④ M-7X-LUS(LUS1A047A)	Solenoid Valve (Group)	⑱ M-7X-PCBC	Control P.C Board
⑤ M-7X-CP	Brass Tube	⑲ M-7X-PCBD3(DMX3P00AB)	P.C Board DMX 3Pin
⑥ M-7X-H	Heater	⑳ M-7X-PCBD5(DMX5P00A5)	P.C Board DMX 5Pin
⑦ C02013500	Handle	㉑ C04101400	Breaker
⑧ D04012000	Snap Bushing	㉒ C04312620	Power Inlet
⑨ C02012100	LED Protect	㉓ W-2RA	W-2 Receiver
⑩ Z15200800-ATR	LED Cover	㉔ M0070001-M7X	Steel Case/Down Base
⑪ M007XRH10	Steel Case/Right Cover	㉕ M-7X-PCB	Main P.C Board
⑫ M-7X-LED	LED (Group)	㉖ M-7X-PC(PCA014201)	Power Cord & Plug
⑬ M-7X-P(PA0EX5A20)	Pump (Group)	㉗ W-2A	Wireless transmitter
⑭ M-7X-FAN	Fan		

Note: This is an exploded diagram of 120V machine, For 220-240V, please contact your local Antari dealer or us.



User Manual

Safety Information



Please read the following safety information carefully before operating the machine. Information includes important safety information about installation, usage, and maintenance. Pay attention to all warning labels and instructions in this manual and printed on the machine.

If you have questions about how to operate the machine safely, please contact your local Antari dealer for help.

- Keep this device dry.
- Always connect to a grounded circuit to avoid risk of electrocution.
- Before connecting the machine to power, always check the voltage indicated on the machine matches to your local AC voltage. Do not use the machine if AC power voltage does not match.
- Disconnect the machine from AC power before servicing and when not in use.
- This product is for indoor use only! Do not expose to rain or moisture. If fluid is spilled, disconnect AC power and clean with a damp cloth. If fluid is spilled onto electronic parts, immediately unplug the machine and contact your local Antari dealer for advice.
- No user serviceable and modifiable parts inside. Never try to repair this product, an unauthorized technician may lead the machine to damage or malfunction.
- For adult use only. Never leave the machine running unattended.
- Installed in a well ventilated area. Provide at least 50 cm space around the machine.
- Never add flammable liquid of any kind to the machine.
- Make sure there are no flammable materials close to the machine while operating.
- Only use Antari fluid. Other fluid may lead to heater clog and malfunction.
- If the machine fails to work, unplug the machine and stop operation immediately. Contact your local Antari dealer for .

- Before transporting the machine, make sure the fluid tank is completely drained.
- Smoke fluid may present health risks if swallowed. Do not drink smoke fluid. Store it securely. In case of eye contact or if fluid is swallowed immediately look for medical advice.

Unpacking and Inspection

Immediately upon receiving the machine, carefully unpack the carton, check all content to ensure that all parts are present and have been received in good condition. If any parts appear damaged or mishandled from shipping, notify the shipper immediately and retain the packing material for inspection.

What is included:

- 1 x M-7X Fogger
- 1 x W-2 Wireless Remote
- 1 x Power Cord
- 1 x User Manual

Product Dimension



Product Overview

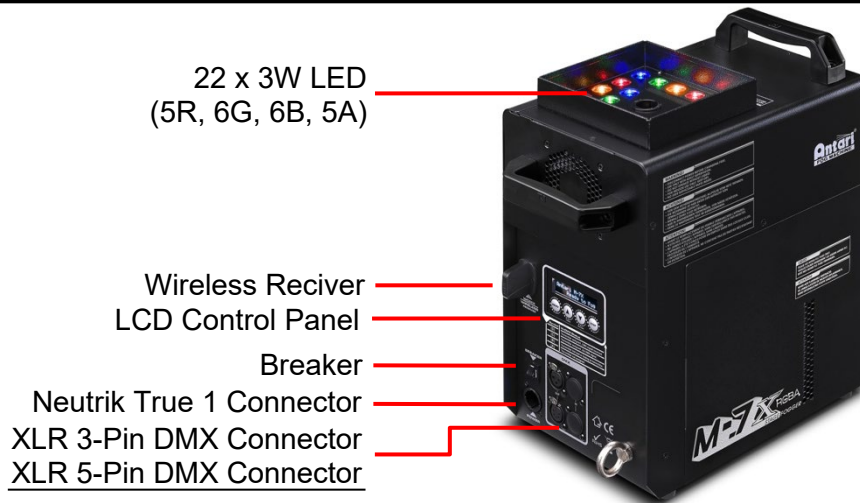

Setting Up

Step 1: Place the machine on a flat surface and in a suitably large area with at least 50 cm open space around the machine.

Step 2: Fill the fluid tank with Antari approved fluid.

Step 3: Connect the machine to suitably rated power supply. To determine the power requirement for the machine refer to the label on the back of the machine.



Always connect the machine to a protected circuit and ensure it is properly grounded to avoid risk of electrocution.

Step 4: Turn on the machine and allow it to heat up. Heat up takes approximately 5 minutes. Once the machine has reached operating temperature, the LCD display will show "Ready To Fog". Now the machine is ready for operation.

Step 5: To start making fog, locate the **Volume** button on the control panel, and press the button to start making fog.

Step 6: To turn off the machine, press **STOP** button and turn Powercon to the **OFF** position.

Operation

Control Panel Operation

The machine can be operated with an onboard digital control interface

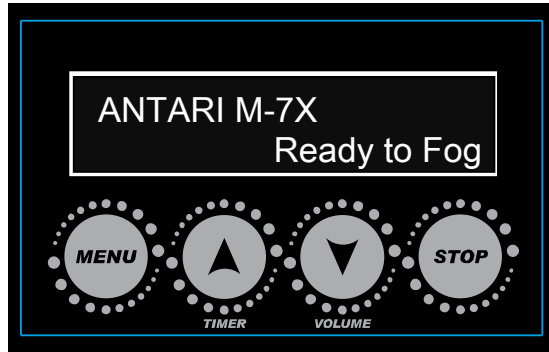

Button	Function
[MENU]	Scroll through setting menu
▲ [UP]/[TIMER]	Up/Activate Timer function
▼ [DOWN]/[VOLUME]	Down/Activate Volume function
[STOP]	Deactivate Timer/Volume function/Return to Standby

Control Menu

DMX512 Address: 1	Set DMX address from 1 to 504
Stand Alone Set Master/Slave	Set machine as Master of Slave unit
Color Mode On/Off	Turn built-in LED color mode On or Off
Color Mode Marco:01-10	Set LED output color from macro 1 to 10

<p>Color Mode Chase:01-15</p>	<p>Set LED chase from 1 to 15</p>
<p>Timer Interval 15 Sec</p>	<p>Set interval from 15 to 360 seconds</p>
<p>Timer Duration 01-05 Sec</p>	<p>Set duration from 1 to 5 seconds</p>
<p>Wireless Setting On</p>	<p>Turn On or Off W-2 wireless control function</p>
<p>Wireless Setting Button A:M01/Off</p>	<p>Set wireless remote button function macro color 1 to 10 or chase 1 to 15 and off.</p>
<p>Wireless Setting Button B:M01/Off</p>	<p>Set wireless remote button function macro color 1 to 10 or chase 1 to 15 and off.</p>
<p>Wireless Setting Button C:M01/Off</p>	<p>Set wireless remote button function macro color 1 to 10 or chase 1 to 15 and off.</p>
<p>Wireless Setting Button D:M01/Off</p>	<p>Set wireless remote button function macro color 1 to 10 or chase 1 to 15 and off.</p>
<p>LED Setting Fog Only/Always On</p>	<p>Setting for LED to turn on with fog only or always on.</p>
<p>LED Fade Out Delay: 0 Sec</p>	<p>Set LED delay time before off from 0.3-0.5 or 0-5 seconds.</p>

Run Last Setting
On/Off

Turn On/Off run last setting function

2-7 Sec Jet Mode
Off/2-7s

Turn On/Off 2-7 Sec Jet Mode; Jet output can be set between 2-7 seconds

W-DMX512
On/Off

Turn On/Off W-DMX

W-DMX Reset
Yes

Rest W-DMX connection

Wireless Operation

Wireless remote control system W-2 consist of a transmitter equipped with four buttons to activate four user configurable LED setting and fog; with an onboard receiver attach to the rear panel of M-7X.



W-2 Wireless Transmitter



Wireless Receiver

Wireless settings are configurable through onboard control panel, refer to control menu section to setup each buttons.

In an open unobstructed space the effective distance is 50 meters, the effective distance depending on obstacle level is 10-25 meters.

Registering transmitter

The transmitter can be paired or deleted from the receiver. Each receiver can pair up to 10 transmitters. Follow the steps below to pair or delete a transmitter from the receiver.

Step 1: Power off M-7X Fogger

Step 2: Press and hold [DOWN] button

Step 3: Turn power on and release [DOWN] button when LCD display blinks

Step 4: Follow the menu instruction to pair or delete transmitter

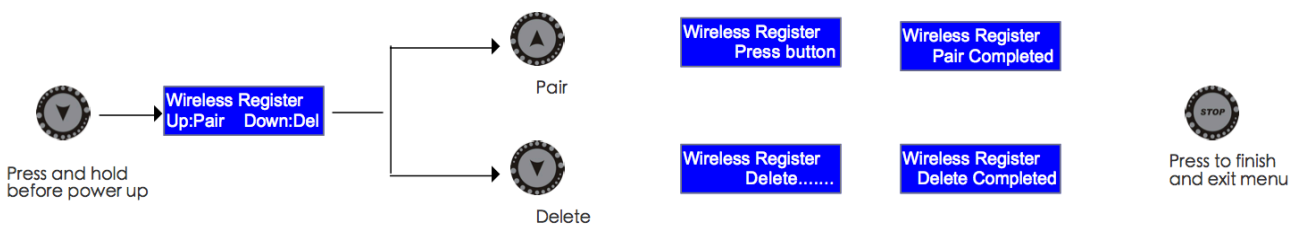

Transmitter battery replacement

If the effective distance appears to be decreased, it is possible the battery level is low and require replacement. In order to replace the battery, undo the three screws on the back of transmitter to release the cover. Replace with the same type and specification of battery which is 27A 12V

DMX Connector Pin Assignment

The machine provides 3 or 5 pin XLR connector for DMX connection. The diagram below indicates pin assignment information.

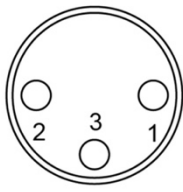

3 Pin XLR

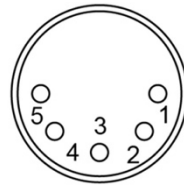
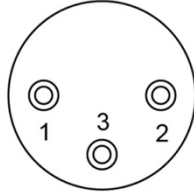

5 Pin XLR

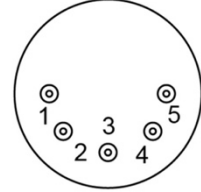

Pin	Function
1	Ground
2	Data-
3	Data+
4	N/A
5	N/A

DMX Channel Function

Channel 1	DMX Value Range	Function
Fog	0 – 4	Fog Off
	5 – 255	Fog On (lasts for 20s)
Channel 2	DMX Value Range	Function
Red LED	0-255	0-100%
Channel 3	DMX Value Range	Function
Green LED	0-255	0-100%
Channel 4	DMX Value Range	Function
Blue LED	0-255	0-100%
Channel 5	DMX Value Range	Function
Amber LED	0-255	0-100%
Channel 6	DMX Value Range	Function
Chase	1-15	Chase 1
	16-31	Chase 2
	32-47	Chase 3
	48-63	Chase 4
	64-79	Chase 5
	80-95	Chase 6
	96-111	Chase 7

	112-127	Chase 8
	128-143	Chase 9
	144-159	Chase 10
	160-175	Chase 11
	176-191	Chase 12
	192-207	Chase 13
	208-223	Chase 14
	224-255	Chase 15
Channel 7	DMX Value Range	Function
Chase Speed	0-255	0-255 step per min
Channel 8	DMX Value Range	Function
Master Dimmer	0-255	0-100%
Channel 9	DMX Value Range	Function
Strobe	0-255	1-20 Hz

Fluid

Use Antari FLC water-based Fluid for the best effect for the M-7X Fogger. The machine is tested and calibrated with this liquid to get the best output performance. Warranty will be voided if any other type of liquid is used, improper use of liquid may lead to machine failure and malfunction.

Service and Maintenance

- Do not allow the machine to become contaminated.
- Remove dust from air vents with air compressor, vacuum or a soft brush.
- Only use a damp cloth to clean the casing.
- Before storing run distilled water through the system to help avoid condensing the pump or heater.
- It is recommended to run the machine on a monthly basis in order to achieve best performance and output condition.
- Excessive dust, liquid and dirt built up will degrade performance and cause overheating.

Breaker Reset



Disconnect AC power before reset breaker. Only replace fuse with same type and rating.

Step 1: Disconnect AC power

Step 2: Flip breaker to ON position

Step 3: Turn on machine to test

Breaker

100V = 16A 250V

120V = 15A 250V

240V = 9A 250V



Technical Specifications

- Input voltage	US model : AC 100-120V, 50 / 60Hz 13A EU model : AC 220-240V, 50 / 60Hz 6.5A
- Rated power	1516W
- Light source	22 x 3W LED (5 Red, 6 Green, 6 Blue, 5 Amber)
- Warm-up time	7 minutes (approx.)
- Fluid consumption	200 ml/min
- Fluid tank capacity	2.4L (0.63gal)
- Compatible fluid	Antari FLC Super Light Fog Fluid
- Ambient temp. range	0°C - 40 °C (32 °F-104 °F)
- Output	10 meters height
- Control	DMX512, Timer, Manual, Wireless, Master/Slave Wireless DMX (Optional)
- DMX channels	9 channels
- Connection	Neutrik TRUE 1 Connector (Power) XLR 3-pin and 5-pin (DMX)
- Optional accessories	WTR-90 Wireless DMX
- Dimension	L344 W193 H381 mm (L13.54 W7.60 H15 inch)
- Weight	14 kg (30.8 lbs)



使用說明書

使用說明及安全注意事項



在使用機器以前，請仔細閱讀以下說明，此份說明書包含了如何在安全的情況下安裝並使用機器，且會說明機器上所有標示的標籤所代表的意義。

如果您有任何使用上的問題，請聯繫當地的 **Antari** 經銷商尋求清楚的說明與協助。

- 保持機器的乾燥。
- 請配合接地型插座，以避免觸電的危險。
- 使用機器前，請確定使用場所的 **AC** 電源規格，與機器電壓規格是否相符。
- 拔開機器和 **AC** 電源插座時，請確認機器已關機不在使用的狀態下。
- 本產品僅限室內使用，請勿將機器暴露在雨中或潮濕的環境，如果有液體(煙霧水)翻倒或溢出，請勿連結機器與 **AC** 電源，用乾布擦拭乾淨，如果任何液體進入機器電子零件，請立即拔除插頭，並連繫當地的 **Antari** 經銷商。
- 本機器不含任何用戶拆解和自行維修或修改的零件在內，請勿嘗試自行維修或改裝機器，未經授權的技術人員，可能導致機器故障或永久損壞。
- 機器限成人操作，請勿在無人值守時讓機器運作。
- 在通風良好的地方安裝使用機器，機器周邊至少應保留 **50** 公分的空間。
- 請勿添加任何易燃物品進入機器。
- 操作機器時請確認周邊沒有任何易燃的材料。
- 為確保機器的使用壽命，請使用 **Antari FLC** 氣柱機專用煙霧水，添加其他液體可能會導致電熱管阻塞和機器的故障。
- 如果機器出現故障，請拔下機器插頭，立即停止工作。並請連繫您當地的 **Antari** 經銷商。
- 運送機器以前，請確認機器的油箱已完全清空。
- 煙霧水不能食用，吞食煙霧水可能導致損壞健康的風險，請將煙霧水存放在室內安全的地方。如果碰觸到眼睛或誤吞食，請立即尋求醫生的協助。

包裝內容

在收到機器後，請立即小心地打開包裝紙箱，檢查所有內容，以確保所有零配件都有齊全收到，並處於良好的狀態。如果有任何部件因運輸過程出現損壞或缺少，請立即連絡經銷商，並以原包裝退回檢查。

內容包括:

- 1 台 M-7X LED 氣柱機
- 1 個 W-2 無線控制器
- 1 條 電源線
- 1 本 使用說明書

機器尺寸



機器外觀概述



設定安裝

步驟 1: 將機器平放於平坦的表面，機器周圍至少應保留 50 公分的空間。

步驟 2: 將 FLC 氣柱機專用煙霧水注入機器所附的油桶，並注意不要拗折到油管。

步驟 3: 將機器連接電源。連接之前，請確認機器背後技術標籤上所標示要求功率，是否與電源相符。



請務必將機器連結到有保護的電路，並確保有正確地接地，以避免觸電的危險。

步驟 4: 啟動機器電源，使機器開始加溫。溫機到工作溫度大約需時 5 分鐘。一旦機器達到工作溫度，LCD 控制面板會顯示“Ready To Fog”。表示機器已經準備好並進行操作。

步驟 5: 欲開始輸出煙霧，將機器正面控制面板上的 **Volume** 按下開始煙霧輸出。

步驟 6: 需關閉本機時，按下 **STOP** 並將 Powercon 電源接頭轉至 **OFF** 的位置。

操作

控制面板操作

使用機器所搭載的數位控制面板進行操作。

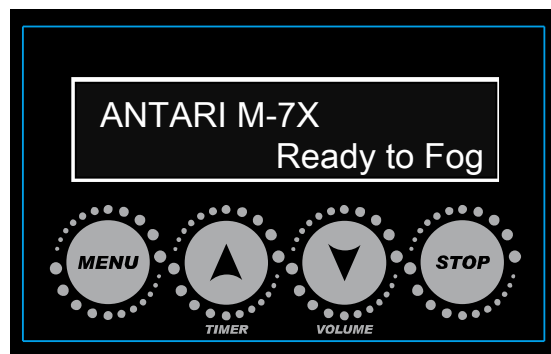

按鈕	功能
[MENU]	瀏覽所有設定清單
▲ [UP]/[TIMER]	增加數值/啟動 定時模式
▼ [DOWN]/[VOLUME]	減少數值/啟動 輸出量模式
[STOP]	取消 定時/輸出量模式 返回待機畫面

控制清單

DMX512 Address: 1	設定 DMX 從 1 至 504 的位址(本機佔用 9 個 DMX 頻道)。
Stand Alone Set Master/Slave	設定機器為主從模式。
Color Mode On/Off	開啟或關閉 LED 燈內置顏色選項。
Color Mode Marco:01-10	選擇 LED 燈已預設在機器上的 10 種固定顏色模式。
Color Mode Chase:01-15	選擇 LED 燈自走變換的 15 種顏色模式。
Timer Interval 15 Sec	設定每次煙霧輸出間隔，範圍是 15 至 360 秒。
Timer Duration 5 Sec	設定持續煙霧輸出時間，範圍是 1 至 5 秒。
Wireless Setting On/Off	啟動或關閉 W-2 無線遙控控制功能。
Wireless Setting Button A:M01	利用 W-2 無線控制器上的 A 鍵記錄最常用的顏色，選擇自 MARCO(已設定)的 10 種或 CHASE(自走)的 15 種選項。
Wireless Setting Button B:M01	利用 W-2 無線控制器上的 B 鍵記錄最常用的顏色，選擇自 MARCO(已設定)的 10 種或 CHASE(自走)的 15 種選項。

<p>Wireless Setting Button C:M01</p>	<p>利用 W-2 無線控制器上的 C 鍵記錄最常用的顏色，選擇自 MARCO(已設定)的 10 種或 CHASE(自走)的 15 種選項。</p>
<p>Wireless Setting Button D:M01</p>	<p>利用 W-2 無線控制器上的 D 鍵記錄最常用的顏色，選擇自 MARCO(已設定)的 10 種或 CHASE(自走)的 15 種選項。</p>
<p>LED Setting Fog Only/Always On</p>	<p>設定 LED 燈功能僅僅在噴煙時有效，或者一直有效。</p>
<p>LED Fade Out Delay: 0 Sec</p>	<p>設定 LED 關閉延遲時間，範圍 0 至 5 秒。</p>
<p>Run Last Setting On/Off</p>	<p>啟動/關閉前次使用最後設定功能。</p>
<p>2 Second Jet Mode Off/2-7s</p>	<p>啟動/關閉 2-7 秒煙霧輸出模式(2-7 Second Jet Mode)。</p>
<p>W-DMX512 On/Off</p>	<p>啟動/關閉 W-DMX 功能</p>
<p>W-DMX Reset Yes</p>	<p>離線 W-DMX 連結 (換控台時，重抓 W-DMX 訊號)</p>

Antari M-7X 無線控制器使用說明

***W-2 無線發射器**

- 發射器：使用 27A 12V 電池
- 接收距離：在無障物的開放空間，有效距離為 50 公尺。

實際狀況根據障礙物多寡，保守距離約為 10-25 公尺。
- W-2 無線發射器配有四個按鈕，可用來啟動使用者設定好的煙霧與 LED 效果。



W-2 無線發射器

***無線接收器**

- 接收器在經過測試後，會固定在 M-7X 的機器後板上，請勿嘗試將它拔除。



無線接收器

***設定功能**

1. 接收器能與發射器對頻及取消對頻
2. 每個接收器可以與 10 組發射器對頻
3. 請按照以下步驟來取消與對頻無線發射器

步驟 1: 關閉 M-7X LED 氣柱機

步驟 2: 按住 [DOWN / 箭頭向下] 按鍵

步驟 3: 啟動機器，當 LCD 螢幕亮起時，放開 [DOWN / 箭頭向下] 按鍵

步驟 4: 按照以下步驟來取消與對頻無線發射器

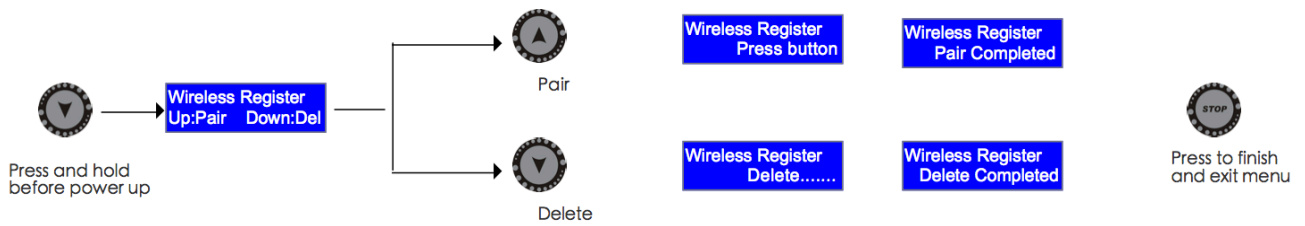

更換 W-2 無線發射器電池

如果無線控制器的有效控制距離縮短，可能是電池的電力不足，需要更換。請將 W-2 發射器背後的三個螺絲旋開，打開背蓋，使用同樣是 27A/12V 的電池更換。

DMX 連接 Pin 點說明

本機可提供 3 Pin 或 5 Pin XLR 的 DMX 連接選擇。下方為 Pin 的接點說明：

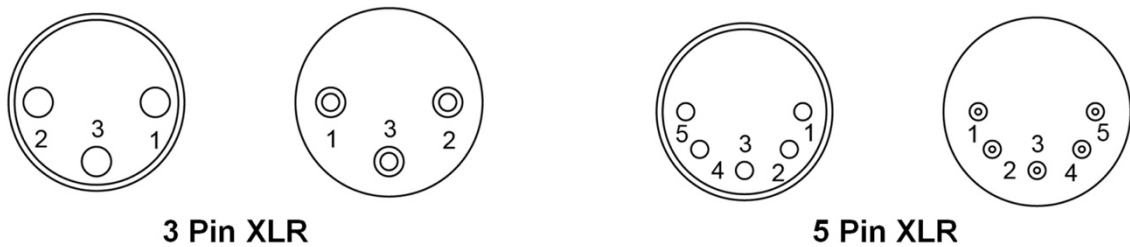

Pin	功能
1	接地
2	數據-
3	數據+

DMX 通道功能

通道 1	DMX 數值範圍	功能
煙霧輸出	0 – 4	煙霧輸出關閉
	5 – 255	煙霧輸出開啟(持續時間 20 秒)
通道 2	DMX 數值範圍	功能
紅色 LED 燈	0-255	0-100%
通道 3	DMX 數值範圍	功能

綠色 LED 燈	0-255	0-100%
通道 4	DMX 數值範圍	功能
藍色 LED 燈	0-255	0-100%
通道 5	DMX 數值範圍	功能
琥珀色 LED 燈	0-255	0-100%
通道 6	DMX 數值範圍	功能
Chase / 自走	1-15	Chase 1
	16-31	Chase 2
	32-47	Chase 3
	48-63	Chase 4
	64-79	Chase 5
	80-95	Chase 6
	96-111	Chase 7
	112-127	Chase 8
	128-143	Chase 9
	144-159	Chase 10
	160-175	Chase 11
	176-191	Chase 12
	192-207	Chase 13
	208-223	Chase 14
	224-255	Chase 15
通道 7	DMX 數值範圍	功能
Chase Speed/自走速度	0-255	每分鐘 0-255 階
通道 8	DMX 數值範圍	功能
Master Dimmer 主控調光器	0-255	0-100%
通道 9	DMX 數值範圍	功能
Strobe/閃動速度	0-255	1-20 Hz

煙油的使用

M-7X LED 燈光氣柱機，僅能使用 Antari FLC 氣柱機專用煙霧水。機器使用 FLC 氣柱機專用煙霧水進行測試與校正，使用此煙霧水將產生最佳的煙霧效果。使用其他的煙霧水，將導致機器故障並使保固失效。

維護與保養

- 請保持機器清潔，不要讓機器髒汙。
- 可以使用空氣壓縮機、吸塵器或軟刷除去機器上的灰塵。
- 機殼可使用濕布擦拭。
- 儲藏機器前，請將蒸餾水倒入油桶並運作機器來清洗加熱系統，避免幫浦與電熱管堵塞。
- 建議每月至少讓機氣溫機並運轉一次，以保持機器處於最佳的性能和輸出條件。
- 機器上過多的灰塵、液體殘餘累積的髒汙，會降低機器工作性能，並導致散熱不良。

重新設置復歸式電流斷路器



重新設置復歸式電流斷路器之前，請關閉電源，並限用同樣類型與等級的復歸式電流斷路器。

步驟 1: 關閉電源

步驟 2: 將復歸式電流斷路器轉至 ON 的位置

步驟 3: 開啟機器測試

復歸式電流斷路器

100V = 16A 250V

120V = 15A 250V

240V = 9A 250V



規格資料

- 電壓
美規 : AC 100-120V, 50 / 60Hz 13A
歐規 : AC 220-240V, 50 / 60Hz 6.5A
- 額定功率
1516 瓦
- 光源
22 x 3 瓦 LED
(紅色 x5, 綠色 x6, 藍色 x6, 琥珀色 x5)
- 加熱時間
(約) 7 分鐘
- 耗油量
200 毫升/分鐘
- 油桶容量
2.4 公升 (0.63 加侖)
- 適用煙霧水
Antari FLC 快速消散煙霧水
- 適用環溫
0°C - 40 °C (32 °F-104 °F)
- 輸出高度
約 10 M 高
- 控制方式
DMX512, 定時控制, 手動控制,
無線控制, 主從模式
無線 DMX (選配)
- DMX512 頻道
占用 9 頻道
- 連接座
Neutrik TRUE1 Connector (主電源)
XLR 3-pin 及 5-pin (DMX512)
- 選擇性配件
WTR-90 無線 DMX 控制模組
- 尺寸
長 344 寬 193 高 381 mm
(長 13.54 寬 7.60 高 15 inch)
- 重量
14 公斤 (30.8 lbs)



For current product information visit Antari at: www.antari.com
For information requests please contact us at: sales@antari.com



C08M07X01

www.antari.com