

## INSTALLATION

Before attempting to install a DVP-AX loudspeaker system please refer to the important warnings and safety instructions. Only qualified personnel should install a loudspeaker system.

Improper installation of a loudspeaker system can cause serious harm and even death if correct procedure is not followed. Anyone attempting installation assumes all liability arising from such use.

### DVP-AX12/DVP-AX15/DVP-AX215 REAR PANEL FEATURES

#### 1. Heat Sink:

The heat sink allows for dissipation of heat build up from the amplifier via air cooling at the rear of the enclosure. Do not obstruct.

#### 2. VOLUME controls for INPUT A and INPUT B:

These knobs control the level of each input channel.

#### 3. DSP Setting icons:

Easy icons which show the applications for the different DSP settings.

#### 4. DSP Selection:

Single knob control to select the 6 different DSP types.

#### 5. 90Hz Filter switch:

Used to reduce bass build up when placed near a wall.

#### 6. Front LED defeat switch:

Switches off the front power LED for discrete applications.

#### 7. GAIN selection switch:

This switch selects the proper gain structure for INPUT A. If a microphone is connected to INPUT A, use mic mode (up). If the signal source is anything other than a microphone (playback device, keyboard or mixer output, for instance) use the line selection (down).

#### 8. Power "ON" indicator LED and LIMIT indicator LED:

The power "ON" LED is illuminated when the power switch is in the "ON" position. The LIMIT LED will illuminate when the signal limiter is limiting the level of the signal to prevent distortion and overload.

#### 9. POWER ON / OFF switch:

This switch turns the power on and off.

#### 10. Output source "LOOP / MIX" switch:

In the "LOOP" mode, this switch routes the signal of both INPUT A and INPUT B to the line level XLR OUTPUT jack, bypassing the EQ section and volume control. When in the MIX mode, this switch routes the combined (or "mixed") signals of both INPUT A and INPUT B to the line level XLR OUTPUT jack.

#### 11. XLR / 1/4" input jacks for INPUT A and INPUT B:

These convenient jacks allow XLR or 1/4" balanced input connections to INPUT A and INPUT B

#### 12. POWER cord receptacle:

This is a receptacle for a standard IEC, three prong, grounded AC electrical connection cord. Be sure that you are plugging into the correct source voltage that matches what is indicated just below the power cord jack.

#### 13. XLR line level OUTPUT jack:

This jack provides a balanced line level output for connection to additional powered subwoofers or amplifiers.

### DVP-AX15B/DVP-AX18B REAR PANEL FEATURES

#### 1. HEAT SINK :

Dissipation of heat build up from the amplifier via air cooling at the rear of the enclosure. Do not obstruct.

#### 2. VOLUME controls for INPUTS:

These knobs control the level of each input channel.

#### 3. INPUTS:

These convenient jacks allow XLR or 1/4" balanced inputs to be made.

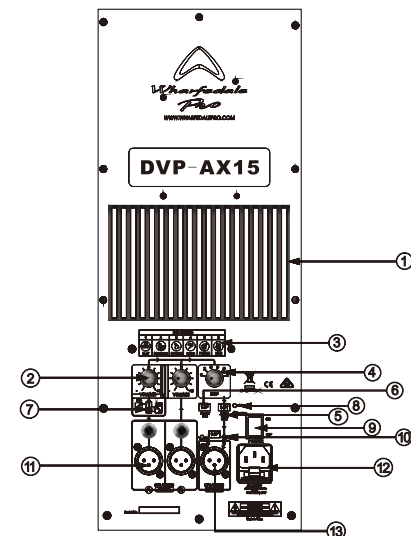

#### WHARFEDALE PRO LIMITED WARRANTY

Wharfedale Pro products are warranted of manufacturing or material defects for a period of one year from the original date of purchase. In the event of malfunction, contact your authorised Wharfedale Pro dealer or distributor for information.

Please be aware that the warranty details may differ from country to country. Contact your dealer or distributor for information (available at [www.wharfedalepro.com](http://www.wharfedalepro.com)). These terms do not infringe your statutory rights.



Wharfedale Professional  
IAG House 13/14 Glebe Road Huntingdon Cambridgeshire PE29 7DL UK  
[www.wharfedalepro.com](http://www.wharfedalepro.com)

Wharfedale Professional reserves the right to alter or improve specifications without notice.  
All rights reserved © 2017 Wharfedale Pro. Wharfedale Pro is a member of the IAG Group.

## WHARFEDALE PRO DVP- AX SERIES USER MANUAL >>>

# DVP-AX SERIES

DVP-AX12 / DVP-AX15 / DVP-AX215

DVP-AX12M / DVP-AX15M

DVP-AX15B / DVP-AX18B

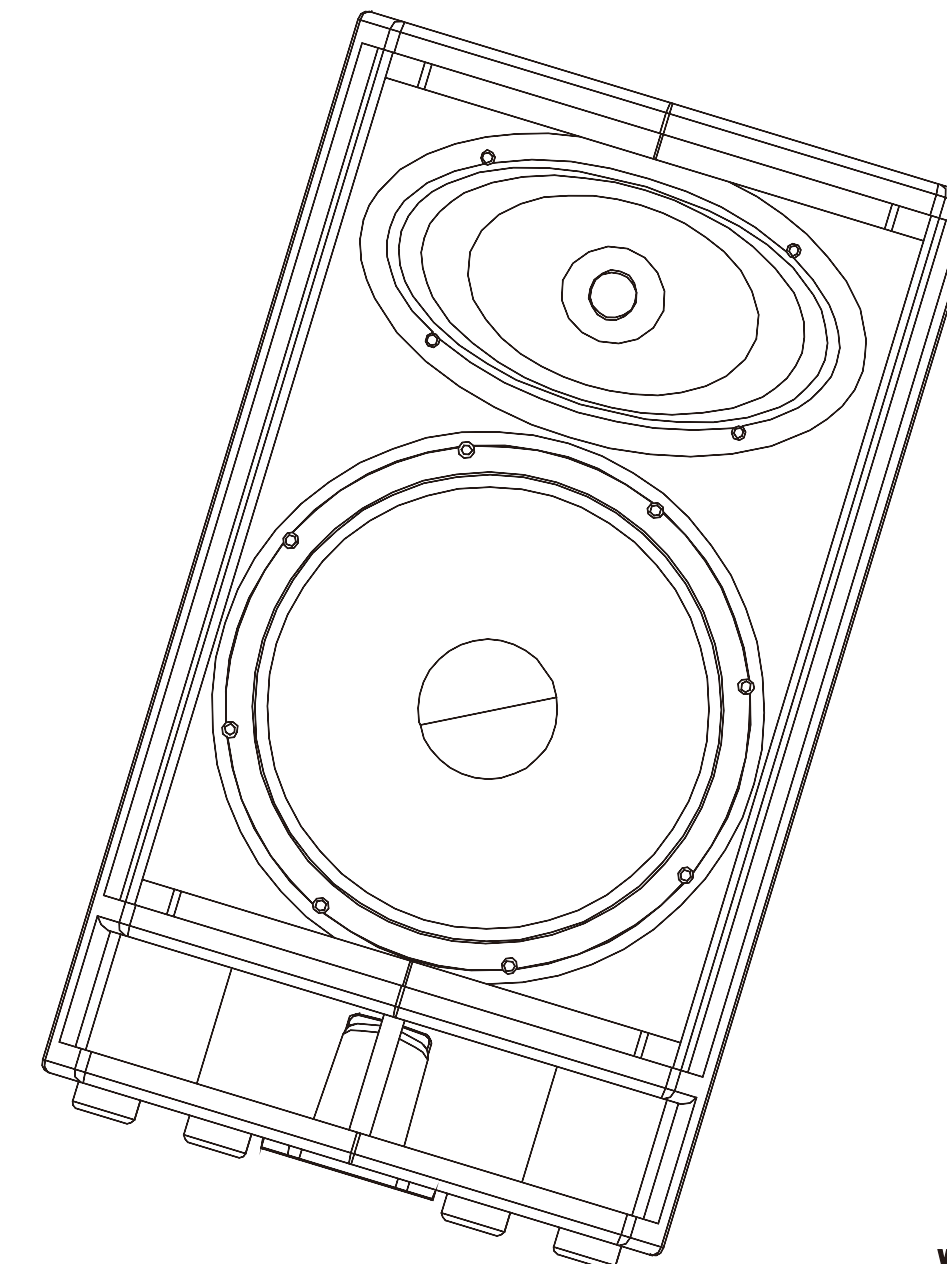

[WWW.WHARFEDALEPRO.COM](http://WWW.WHARFEDALEPRO.COM)

#### 4. OUTPUTS:

A balanced male XLR connector provides a HIGH PASS output signal

#### 5. POWER cord receptacle:

This is a receptacle for a standard IEC, three prong, grounded AC electrical connection cord. Be sure that you are plugging into the correct source voltage that matches what is indicated just below the power cord jack.

#### 6. LIMIT LED/ POWER LED :

The green LED indicator illuminates when the unit is powered up. The red LED illuminates when the signal limiting function is activated.

#### 7. POWER ON / OFF switch:

This switch turns the power on and off.

#### 8. PHASE SWITCH:

Selects the polarity of the signal being sent to the subwoofer. 0° selects the signal polarity as it appears at the input. The 180° selection inverts the polarity of the signal.

#### 9. CROSSOVER FREQUENCY CONTROL:

Adjustable 80Hz to 200Hz frequency range.

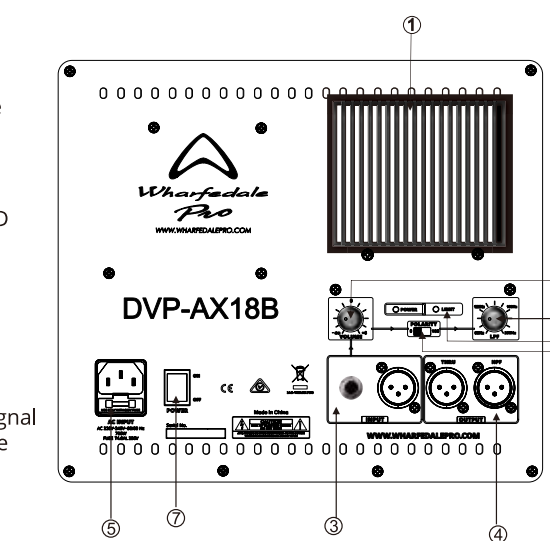

### DVP-AX12M/DVP-AX15M REAR PANEL FEATURES

#### 1. VOLUME controls for INPUT A and INPUT B:

These knobs control the level of each input channel.

#### 2. 7 band EQ:

Use this 7-band graphic EQ to cut or boost the signal by up to 12dB at designed frequencies. This is useful for reducing low frequency rumble or feedback that can occur on stage.

#### 3. XLR and 1/4" input jacks for INPUT A and INPUT B:

These convenient jacks allow XLR or 1/4" balanced input connections to INPUT A and INPUT B

#### 4. Power "ON" indicator LED and LIMIT indicator LED:

The power "ON" LED is illuminated when the power switch is in the "ON" position. The LIMIT LED will illuminate when the signal limiter is limiting the level of the signal to prevent distortion and overload.

#### 5. Output source "LOOP / MIX" switch:

In the "LOOP" mode, this switch routes the signal of INPUT A and INPUT B to the line level XLR OUTPUT jack, bypassing the EQ section and volume control. When in the MIX mode, this switch routes the combined (or "mixed") signals of both INPUT A and INPUT B to the line level XLR OUTPUT jack.

#### 6. XLR line level OUTPUT jack:

This jack provides a balanced line level output for connection to additional powered subwoofers or amplifiers.

#### 7. Speaker out:

The Speaker Out is a post EQ, powered output designed for speakers with a minimum impedance of 8 ohms. This output should only be connected to non-powered monitor speakers. The DVP-X12M/X15M are the perfect extension monitor to use in this application.

#### 8. Power switch:

Use this switch to turn the unit on and off.

#### 9. Power cord receptacle:

This is a receptacle for a standard IEC, three prong, grounded AC electrical connection cord. Be sure that you are plugging into the correct source voltage that matches what is indicated just below the power cord jack.

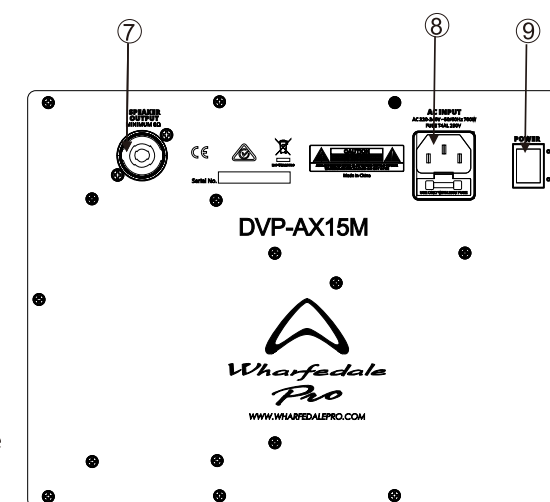
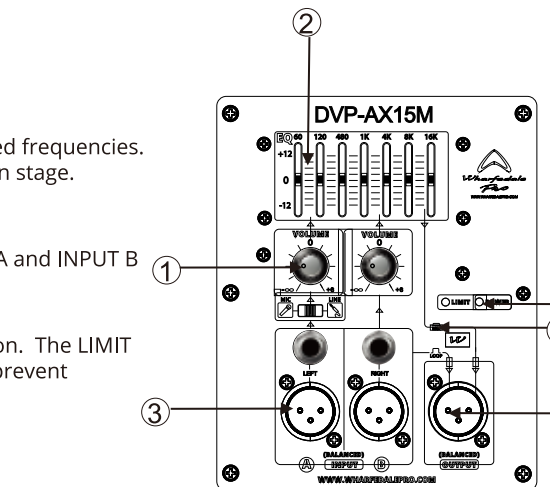

◆ **Damage to the equipment may occur if an improper line voltage is used.**

◆ **Never remove or cut the ground pin of the line core plug.**

## WARNING AND SAFETY INSTRUCTIONS

### 1. READ ALL INSTRUCTIONS

Carefully read and become familiar with the features and functions of these products before operating them.

### 2. RETAIN THESE INSTRUCTIONS

For future reference.

### 3. COMPLY WITH ALL WARNINGS

All warnings and instructions for this product should be adhered to.

### 4. USE WITH AMPLIFIERS

In order to avoid damage to drivers and other equipment, it is advisable to establish and follow a routine for powering up and powering down a sound system. With all system components connected, turn on source equipment (mixers, signal processors, record and playback units, etc.) BEFORE powering up amplifiers. Transient voltages from powering up source equipment can damage speakers if amplifiers are already turned on. Make sure that amplifier volumes are set to their minimum settings and power up any system amplifiers LAST. It is recommended that all system components be allowed to stabilise for several seconds before powering down any other system components.

### 5. CABLES

Do not use shielded or microphone cables for connection between amplifiers and speakers. Use only approved speaker cables with proper connectors.

### 6. RIGGING – SUSPENDING – MOUNTING

Rigging, suspending and mounting of these speaker systems can expose members of the public to serious health risks and even death. Under no circumstances attempt to rig, suspend or otherwise mount these speakers unless you are fully qualified and certified to do so by relevant local, state and national authorities. All relevant safety regulations must be followed. If you are not properly qualified or do not know of pertinent regulations, consult qualified personnel for advice.

### 7. CAUTION

These professional loudspeaker systems are capable of generating very high sound pressure levels. Use care with placement and operation to avoid exposure to excessive volume levels. Permanent hearing damage can result when operated to extreme levels.

### 8. SERVICE

There are no user serviceable parts inside the product. Users should not attempt to service this product. Warranty nullification could result if this is attempted.

## INTRODUCTION

DVP-AX is a comprehensive lineup of versatile and road-ready active loudspeakers. Class D amplification housed in ultra hard wearing cabinets make DVP-AX the perfect choice for hard working DJs and musicians on the road.

The full-range models feature advanced DSP processing with 6 presets tailored to overcome many real-life sonic challenges and a handy 2 channel mic/line mixer makes life on stage easier. The floor monitor models feature a 7-band EQ to help deliver maximum volume without feedback. DVP-AX delivers advanced electronics - but in a road-ready cabinet.

## KEY FEATURES

- Advanced DSP with a 6-position switch for multi-use presets
- 2 channel mixer with mic, line level and balanced XLR output
- Floor monitors feature 7-band EQ and Speaker output for connection to an additional passive "slave" speaker
- Individually tuned front ported systems for clear, punchy bass
- Extended-range IRIS X Titanium dome HF driver
- High powered LF driver using a double-roll surround
- Fine-tuned crossover, built in house for audio signal purity and optimised tuning
- Enhanced Rhino Rock paint finish

## SPECIFICATIONS

Model Name	DVP-AX12	DVP-AX12M	DVP-AX15	DVP-AX15M	DVP-AX215	DVP-AX15B	DVP-AX18B
System Type	Active 12" 2-way	Active 12" 2-way monitor	Active 15" 2-way	Active 15" 2-way monitor	Active 2x15" 2-way	Active 15" subwoofer	Active 18" subwoofer
Frequency Response (+/-3dB)	60-18KHZ	60-18KHZ	50-18KHZ	55-18KHZ	45-18KHZ	45-150HZ	35-150HZ
Frequency Range (-10 dB)	55-20KHZ	55-20KHZ	45-20KHZ	50-20KHZ	40-20KHZ	38-150HZ	30-150HZ
Maximum SPL(peak)(@1m)	129dB	129dB	130dB	130dB	135dB	130dB	132dB
Sensitivity @ 1W / 1m	98dB	98dB	98dB	98dB	101dB	98dB	99dB
Low Frequency Transducer							
Size (mm / inches)	305mm/12"	305mm/12"	381mm/15"	381mm/15"	2X381mm/15"	381mm/15"	470mm/18"
Coil Size (mm / inches)	Dual layer 2.5"	Dual layer 2.5"	Dual 2 layer 2.5"	Dual 2 layer 2.5"	Dual 2 layer 2.5"	Dual layer 2.5"	Quad layer 2.5"
Rated Impedance	4Ω	8Ω	4Ω	8Ω	2X8Ω	4Ω	4Ω
High Frequency Transducer							
Type	Compression Driver	Compression Driver	Compression Driver	Compression Driver	Compression Driver		
Coil Size (mm / inches)	44mm/1.75"	44mm/1.75"	44mm/1.75"	44mm/1.75"	44mm/1.75"		
Exit Size (mm / inches)	25mm/1"	25mm/1"	25mm/1"	25mm/1"	25mm/1"		
Diaphragm Material	Titanium	Titanium	Titanium	Titanium	Titanium		
Impedance	8Ω	8Ω	8Ω	8Ω	8Ω		
Nominal Coverage (H x V)	90°x60°	90°x60°	90°x60°	90°x60°	90°x60°		
Rated Impedance	8Ω	8Ω	8Ω	8Ω	8Ω		
Amplifiers							
Low-Frequency Power Amplifier -Class D, RMS/Peak Watts	150W/600W	250W/1000W(8Ω) 500W/2000W(4Ω)	350W/1400W	250W/1000W(8Ω) 500W/2000W(4Ω)	500W/2000W	600W/2400W	600W/2400W
High-Frequency Power Amplifier -Class D RMS/Peak Watts	50W/200W	N/A	50W/200W	N/A	70W/280W	N/A	N/A
DSP	Yes	N/A	Yes	N/A	Yes	N/A	N/A
		7-band EQ		7-band EQ		N/A	N/A
Controls---EQ	1:FLAT 2:MONITOR 3:SPEECH 4:BASS 5:PUNCH 6:LIVE	60Hz 120Hz 480Hz 1KHz 4KHz 8KHz 16KHz	1:FLAT 2:MONITOR 3:SPEECH 4:BASS 5:PUNCH 6:LIVE	60Hz 120Hz 480Hz 1KHz 4KHz 8KHz 16KHz	1:FLAT 2:MONITOR 3:SPEECH 4:BASS 5:PUNCH 6:LIVE	N/A	N/A
Amplifier Protection	Yes	Yes	Yes	Yes	Yes	Yes	Yes
Power On Protection	Yes	Yes	Yes	Yes	Yes	Yes	Yes
Thermal Protection	Yes	Yes	Yes	Yes	Yes	Yes	Yes
Low Line Voltage Shut Down	Yes	Yes	Yes	Yes	Yes	N/A	N/A
Driver Protection							
DC Protection	Yes	Yes	Yes	Yes	Yes	Yes	Yes
Short Protection	Yes	Yes	Yes	Yes	Yes	Yes	Yes
Clip Limiter	Yes	Yes	Yes	Yes	Yes	Yes	Yes
Limiter Indicator	Red LED	Red LED	Red LED	Red LED	Red LED	Red LED	Red LED
Front Power Indicator	Red LED	Red LED	Red LED	Red LED	Red LED	Red LED	Red LED
Power Indicator	Green LED	Green LED	Green LED	Green LED	Green LED	Green LED	Green LED
Inputs							
Input A - type	Balanced	Balanced	Balanced	Balanced	Balanced	Balanced	Balanced
Input Sensitivity	775mv	775mv	775mv	775mv	775mv	775mv	775mv
Maximum Input Level	4v	6v	4v	6v	4v	6v	6v
Input Connector	2 * XLR & 2 * 1/4" (Line/Mic)	2 * XLR & 2 * 1/4" (Line/Mic)	2 * XLR & 2 * 1/4" (Line/Mic)	2 * XLR & 2 * 1/4" (Line/Mic)	2 * XLR & 2 * 1/4" (Line/Mic)	XLR & 1/4" (Line/Mic)	XLR & 1/4" (Line/Mic)
Input Impedance	Balanced:20K	Balanced:20K	Balanced:20K	Balanced:20K	Balanced:20K	Balance:20K	Balance:20K
LPF control	N/A	N/A	N/A	N/A	N/A	80Hz-120Hz	80Hz-120Hz
Polarity Control	N/A	N/A	N/A	N/A	N/A	0°/180°	0°/180°
Line Output							
Line Output Connector	XLR	XLR(Balance out)	XLR	XLR(Balance out)	XLR	XLR THRU/HPF(OUT)	XLR THRU/HPF(OUT)
Impedance Balanced							
Loop Gain	0dB	0dB	0dB	0dB	0dB	0dB	0dB
AC Power details							
Power Supply	SMPS	SMPS	SMPS	SMPS	SMPS	SMPS	SMPS
AC Power Options	220-240V 50/60Hz 100-120V 50/60Hz	220-240V 50/60Hz 100-120V 50/60Hz	220-240V 50/60Hz 100-120V 50/60Hz	220-240V 50/60Hz 100-120V 50/60Hz	220-240V 50/60Hz 100-120V 50/60Hz	220-240V 50/60Hz 100-120V 50/60Hz	220-240V 50/60Hz 100-120V 50/60Hz
Pole socket handles	Dual-angle (0° or -10°) 35 mm pole socket 2 carry handles (one of each side)	N/A 2 carry handles (one of each side)	Dual-angle (0° or -10°) 35 mm pole socket 2 carry handles (one of each side)	N/A 2 carry handles (one of each side)	N/A 2 carry handles (one of each side)	35 mm pole socket 2 carry handles (one of each side)	35 mm pole socket 2 carry handles (one of each side)
Enclosure Material and finish	MDF	MDF	MDF	MDF	MDF	MDF	MDF
Colour Options	black paint	black paint	black paint	black paint	black paint	black paint	black paint
Grille Material & Finish	steel	steel	steel	steel	steel	steel	steel
Dimensions - Unpacked (mm / inches):							
Height	617mm/24.3in	428mm/16.9in(SITU)	689mm/27.1in	520mm/20.5in(SITU)	1058mm/41.7in	591mm/23.3in	650mm/25.6in
Width	361.2mm/14.2in	359mm/14.1in	443.5mm/17.5in	449mm/17.7in	444.5mm/17.5in	454mm/17.9in	528mm/20.8in
Width (rear)	207.6mm/8.2in	359mm/14.1in	243.5mm/9.6in	449mm/17.7in	245.3mm/9.7in	454mm/17.9in	528mm/20.8in
Depth	342.4mm/13.5in	537mm/21.1in	429.0mm/16.9in	640mm/25.2in	429.0mm/16.9in	534mm/21.0in	639mm/25.2in
Dimensions - Packed (mm / inches):							
Height	680mm/26.8in	396mm/15.6in	750mm/29.5in	485mm/19.1in	1125mm/44.3in	681mm/26.8in	740mm/29.1in
Width	438mm/17.3in	573mm/22.6in	520mm/20.5in	676mm/26.6in	520mm/20.5in	620mm/24.4in	725mm/28.5in
Width (rear)	236mm/9.3in	573mm/22.6in	290mm/11.4in	676mm/26.6in	290mm/11.4in	620mm/24.4in	725mm/28.5in
Depth	428mm/16.9in	448mm/17.6in	485mm/19.1in	541mm/21.3in	496mm/19.5in	540mm/21.3in	614mm/24.2in
Weight							
Net Weight (kg / lbs)	18.9kg/41.6lbs	19.7kg/43.3lbs	23.3kg/51.3lbs	23.0kg/50.6lbs	35.8kg/78.8lbs	28.8kg/63.4lbs	36.4kg/80.1lbs
Gross Weight (kg / lbs)	21.9kg/48.2lbs	22.8kg/50.2lbs	27.3kg/60.1lbs	26.3kg/57.9lbs	40.1kg/88.2lbs	32.8kg/72.2lbs	43.1kg/94.8lbs