

AirLine 77

OWNERS MANUAL

UHF WIRELESS SYSTEM

- AL1 Presentation Transmitter
- AX1 Handheld Transmitter
- CR77 Receiver

SAMSON[®]



PRESENTATION
TRANSMITTER



HANDHELD TRANSMITTER

If you've had some prior experience using wireless systems, these QuickStart instructions will get you up and running with your AirLine system in a matter of minutes! Detailed instructions for setting up and using your AirLine system can be found on page 17 of this manual, and the "Guided Tour" sections on pages 6 - 16 provide full descriptions of all AirLine component controls and displays.

1. Make sure that the supplied receiver and AX1 or AL1 transmitter are factory preset to the same channel.
2. Physically place the receiver where it will be used and extend its antenna(s) vertically.
3. Set the power switch to your transmitter to the "off" position (away from the arrow) and place a fresh battery in it. Then turn the transmitter back on momentarily; its LED will flash once and then go off if the battery is sufficiently strong. Once battery strength is verified, turn the transmitter off.
4. If you are using an AX1, plug its XLR connector into a wired dynamic microphone; make a good tight connection, using the supplied rubber gasket if necessary. If you are using the AL1 with an external lavalier microphone, make the physical connection between its input connector and the microphone.
5. Turn your audio system off and make the physical cable connection between the receiver's balanced or unbalanced output jack (if necessary, both can be used simultaneously) and a mic level audio input of your amplifier or mixer. If your system contains a CR77 or UM1 receiver, be sure to set its Audio Output Level switch correctly.
6. Turn the Volume, Level or AF Level knob on the receiver completely counterclockwise. Connect the supplied AC adapter to the receiver and plug it in (or place a fresh battery in the UM1 receiver), but leave its power off for the moment.
7. Turn on the receiver. If your system contains a CR77 receiver, its "Power" LED will light steadily red. (Note: the UM1 receiver has no such LED.)

8. Turn on your transmitter. If your system contains either a CR77 or UM1 receiver, one of the "A/B Receiver" LEDs will be lit, showing you whether the (left) "A" or (right) "B" receiver is currently being used. The CR77 / UM1 meter will also indicate the strength of the incoming RF signal.
9. Turn on your connected amplifier and/or mixer but keep its volume all the way down. If your system contains an AL1 transmitter, make sure it is unmuted. Set the Volume, Level or AF Level knob on the receiver fully clockwise; this is unity gain.
10. Speak or sing into your mic at a normal performance level while slowly raising the audio input control of your amplifier or mixer until the desired level is reached. If necessary, use the supplied plastic screwdriver to adjust the transmitter's Gain trimpot in order to increase or decrease its signal level. If you are using an AL1 transmitter with the built-in microphone, correct placement is critical to sound quality. It should be unobstructed by clothing and either clipped to a shirt pocket or lapel, or worn around the neck on the supplied lanyard.
11. Do a walkaround through the intended area of coverage while observing the receiver's "Power/RF" LED or RF Meter; it should indicate sufficient RF reception in all areas of coverage. Reposition it (or its antenna) as necessary. If extended range coverage is required, a Samson CR77 or UM1 true diversity receiver (set to the same channel as the transmitter) should be used.
12. If you hear any spurious noise from the receiver output when the transmitter is turned off, use the supplied plastic screwdriver to adjust the receiver Squelch level control, slowly turning it clockwise to the point at which the noise disappears.

Guided Tour - CR77 Receiver / Front Panel

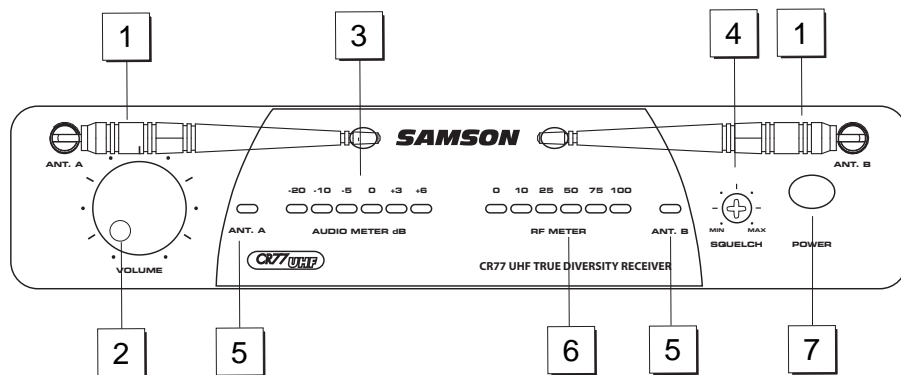

1: Antennas (A and B) - The antenna mountings allow full rotation for optimum placement. In normal operation, both Antenna A (the antenna on the left) and Antenna B (the antenna on the right) should be placed in a vertical position. Both antennas can be folded inward for convenience when transporting the CR77. See the "Setting Up and Using the AirLine System" section on page 17 in this manual for information about antenna installation and positioning.

2: Volume control - This knob sets the level of the audio signal being output through both the balanced and unbalanced output jacks on the rear panel (see #2 and #4 on page 8 in this manual). Reference level is obtained when the knob is turned fully clockwise (to its "10" setting).

3: Audio Meter - - This "ladder" display (similar to the VU bar meter used on audio devices) indicates the strength of the incoming audio signal. When the "0" segment is lit, the incoming signal is optimized at unity gain; when the "+6" segment is lit, the signal is overloading. When only the left-most "-20" segment is lit, the incoming signal is at just 10% of optimum strength. If no segments are lit, little or no signal is being received. See the "Setting Up and the AirLine System" section on page 16 in this manual for more information.

4: Squelch control - This control determines the maximum range of the CR77 before audio signal dropout. Although it can be adjusted using the supplied plastic screwdriver, it should normally be left at its factory setting. See the "Setting Up and Using the AirLine System" section on page 17 in this manual for more information.

5: A/B Receiver LEDs - When signal is being received, one of these will be lit green, showing you whether the (left) "A" or (right) "B" receiver is currently being used. The CR77 constantly scans its two antennas and automatically selects whichever is receiving the strongest, clearest signal. This **True Diversity** switching is completely inaudible, but it effectively increases overall range while virtually eliminating potential interference and phase cancellation problems.

6: RF (Radio Frequency) Level meter - This "ladder" display (similar to the VU bar meter used on audio devices) indicates the strength of the incoming radio signal. When the "100%" segment is lit, the incoming RF signal is fully modulated and at optimum strength. When only the second most left-most "10%" segment is lit, the incoming signal is at just 10% of optimum strength. If no segments are lit, little or no signal is being received. See the "Setting Up and Using the AirLine System" section on page 17 in this manual for more information.

8: Power switch - Use this to turn the CR77 power on and off. When the receiver is on, the internal Power LED is lit.

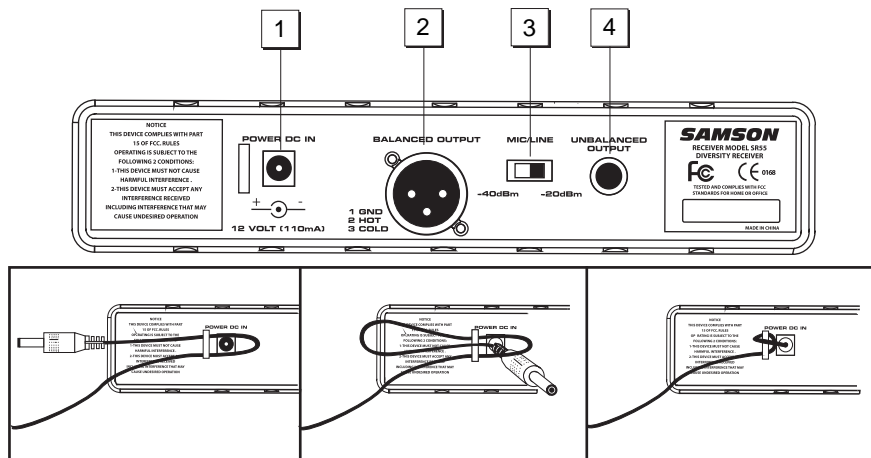

Using the strain relief: Gather up a loop of wire and pass it through the strain relief, then pass the adapter plug through the loop in order to create a knot.

electronically balanced low impedance (600 Ohm) XLR jack when connecting the CR77 to professional (+4) audio equipment. Pin wiring is as follows: Pin 1 ground, Pin 2 high (hot), and Pin 3 low (cold).

* If required, both the unbalanced and balanced outputs can be used simultaneously.

1: DC input - Connect the supplied 12 volt 160 mA power adapter here, using the strain relief as shown in the illustration below. **WARNING:** Do **not** substitute any other kind of power adapter; doing so can cause severe damage to the CR77 and will void your warranty.

2: Unbalanced output* - Use this unbalanced high impedance (5K Ohm) 1/4" jack when connecting the CR77 to consumer (-10) audio equipment. Wiring is as follows: tip hot, sleeve ground.

3: Audio Output Level switch - Sets the audio output level attenuation of the balanced output (see #4 below) to -20 dBm (line level) or -40 dBm (mic level). See "Setting Up and Using the AirLine System" on page 17.

4: Balanced output* - Use this elec-

1: A/B Receiver LEDs - When signal is being received, one of these will be lit orange, showing you whether the (left) "A" or (right) "B" receiver is currently being used. The UM1 constantly scans its two antennas and automatically selects whichever is receiving the strongest, clearest signal. This True Diversity switching is completely inaudible, but it effectively increases overall range while virtually eliminating potential interference and phase cancellation problems.

2: Meter - This set of three multicolor LEDs acts as a meter, indicating either battery power or the strength of the incoming RF signal. This meter can also be disabled altogether to conserve battery power. See #15 on page 11 for more information.

3: Peak LED - This LED lights red when output signal from the UM1 is at the onset of clipping (that is, when it is on the verge of being distorted). If you see this light during operation, move the microphone further away or lower the output level of your instrument or transmitter. For more information, see the section entitled "Setting Up and Using the AirLine System" on page 17 in this manual.

4: Power switch - Use this to turn the UM1 power on and off.

5: SQ (Squelch) Level control - This control determines the maximum range of the UM1 before audio signal dropout. Although it can be adjusted using the supplied plastic screwdriver, it should normally be left at its factory setting. See the "Setting Up and Using the AirLine System" section on page 17 in this manual for more information.

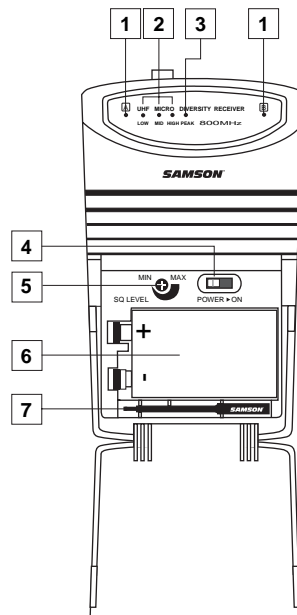

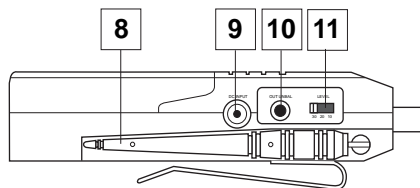

6: Battery holder - Insert a standard 9-volt alkaline battery here, being sure to observe the plus and minus polarity markings shown. We recommend the Duracell MN 1604 type battery. Although rechargeable Ni-Cad batteries can be used, they do not supply adequate current for more than four hours.

WARNING: Do not insert the battery backwards; doing so can cause severe damage to the UM1 and will void your warranty.

7: Plastic screwdriver - Specially designed for use in adjusting the UM1 Squelch Level control (see #4 on the previous page). See the "Setting Up and Using the AirLine System" section on page 17 in this manual for more information.

8: Antennas (A and B) - The antenna mountings allow full rotation for optimum placement. In normal operation, both antennas should be placed in a vertical position. Both antennas can be folded inward for convenience when transporting the UM1. See the "Setting Up and Using the AirLine" section on page 17 in this manual for more information.

9: DC input - This jack will accept a DC input voltage of 6 - 13 volts (inner connection [tip] positive, outer connection [sleeve] ground) from your video camera, if available. Connect an optional Samson AC300R adapter here to charge a rechargeable 9-volt Ni-Cad battery.

10: Unbalanced output* - Use this unbalanced (1K Ohm max.) 1/8" (3.5 mm) mini-phone jack when connecting the UM1 to consumer (-10) audio equipment. Wiring is as follows: tip hot, sleeve ground. If your video camera has stereo audio inputs, you'll need to use a Y-adaptor that has a 1/8" (3.5 mm) mini-phone plug at one end and dual male RCA-type plugs at the other end.

11: Audio Output Level switch - Sets the audio output level of both the balanced and unbalanced outputs (see #10 above and #14 on the following page) to -30 dBm (mic level), -20 dBm, or -10 dBm (line level). See the "Setting Up and Using the AirLine System" section on page 17 in this manual for more information.

12: Level control - This knob sets the level of the audio signal being sent to the headphones output (see #13 below).

13: Headphones output - Connect a stereo headphone to this standard 1/8" (3.5 mm) mini-phone jack in order to monitor the signal being output by the UM1. We recommend the use of 30 ohm headphones. The level of the headphone signal can be set by adjusting the Level control (see #12 above). Maximum output is 240 mW @ 30 ohms).

14: Balanced output* - Use this electronically balanced low impedance (600 Ohm) mini-XLR jack when connecting the UM1 to professional (+4) audio equipment. Pin wiring is as follows: Pin 1 ground, Pin 2 high (hot), and Pin 3 low (cold).

15: Meter switch - This three-position switch determines the function of the front-panel UM1 meter (see page #2 on page 9). In the left "RF" position, the meter indicates the strength of the incoming RF signal. In the center "BATTERY" position, the meter indicates relative battery power, showing whether the installed battery is at low (red), mid (yellow) or high (green) strength. (Note: When the red "low" indicator lights, performance is degraded and the battery needs to be replaced). In the right "OFF" position, the meter is disabled altogether, thus conserving battery power.

* If required, both the unbalanced and balanced outputs can be used simultaneously.

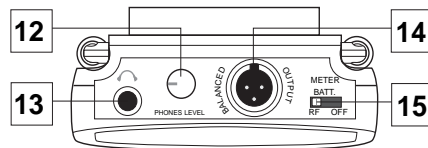

1: XLR connector - Connect this standard female XLR connector into any standard wired dynamic microphone in order to make it a wireless mic.

2: Rubber gasket - If necessary, use this provided rubber gasket in order to make a solid connection between the AX1 XLR connector and your microphone (note that not all microphones require its use).

3: Power on-off switch - Move this switch in the direction of the arrow to turn power to the AX1 on; move it away from the arrow to turn power off. (to conserve battery power, be sure to turn the AX1 off when not in use). Be sure to mute the audio signal at your external mixer or amplifier before turning the AX1 power on or off, or an audible pop may result.



4: Power / Battery LED - This LED flashes once when the AX1 is first turned on and lights steadily red when there is less than 2 hours of battery power remaining, indicating that the battery needs to be changed.

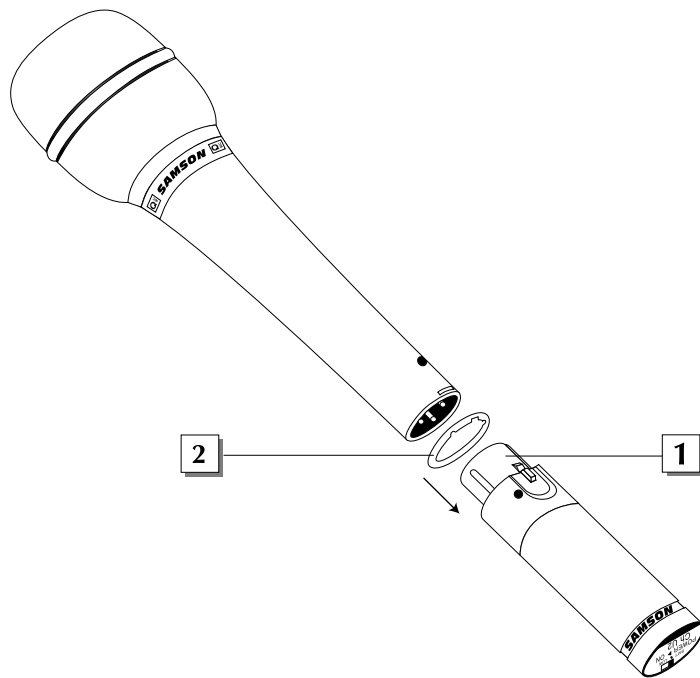

Guided Tour - AX1 Handheld Transmitter

Samson AirLine

5: Battery compartment - Insert a standard AAA alkaline battery here, being sure to observe the plus and minus polarity markings shown. We recommend the Duracell type battery. Although rechargeable Ni-Cad batteries can be used, they do not supply adequate current for more than four hours. **WARNING:** Do not insert the battery backwards; doing so can cause severe damage to the AX1 and will void your warranty.

6: Microphone Input Level control (trimpot) - Use the supplied plastic screwdriver to raise or lower the input level sensitivity of the AX1 as required. See the "Setting Up and Using Your AirLine System" section on page 17 in this manual for more information.

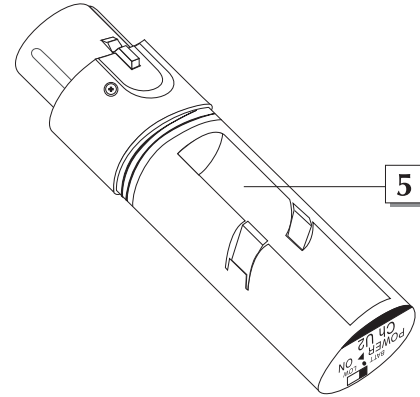
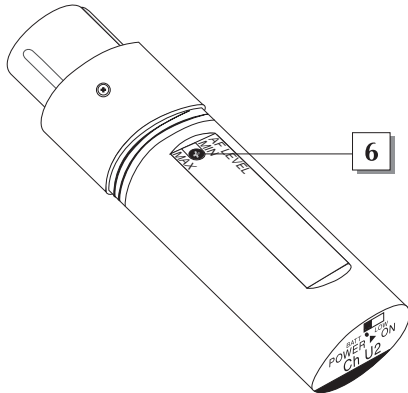

ENGLISH

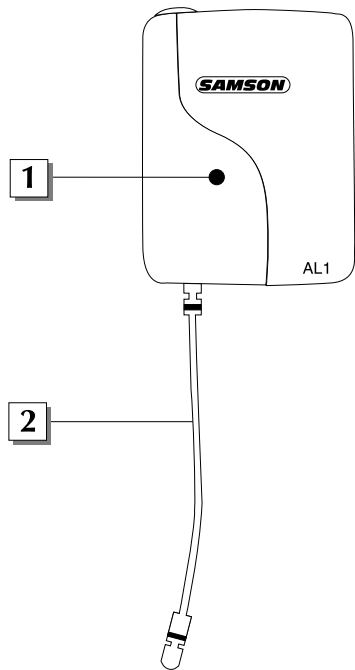

1: Power / Battery LED - This LED flashes once when the AL1 is first turned on and lights steadily red when there is less than 2 hours of battery power remaining, indicating that the battery needs to be changed.

2: Antenna - This permanently attached flexible antenna should be fully extended during normal operations. See the "Setting Up and Using Your AirLine System" section on page 17 in this manual for more information about antenna positioning.

3: Electret condenser microphone - This high-quality unidirectional electret condenser microphone with metal windscreen is optimized for clear, crisp reproduction of speech. It is active whenever the AL1 is powered on, as long as there is no connection made to the lavalier microphone input connector (see #4 below). When a plug is inserted into the lavalier microphone input connector, this built-in microphone is muted.

4: Lavalier microphone input connector - Use this standard 2.5 mm mini-jack if you want to connect an external lavalier microphone to the AL1. Note that, because the AL1 has a built-in electret condenser microphone (see #3 above), the use of an external lavalier mic is optional and not required. The AL1 provides 2.7V of phantom power, so condenser mics can be used if desired.

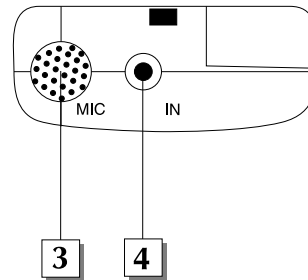

Guided Tour - AL1 Presentation Transmitter *Samson AirLine*

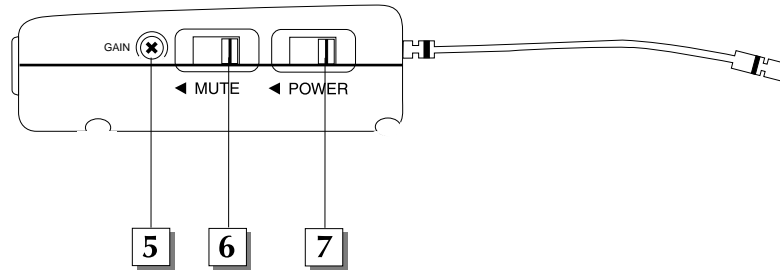

5: Gain control (trimpot) - Use the supplied plastic screwdriver to raise or lower the input level sensitivity of the AL1 as required. See the "Setting Up and Using Your AirLine System" section on page 17 in this manual for more information.

6: Mute switch - Move this switch in the direction of the arrow to mute the AL1; move it away from the arrow to unmute it and transmit audio signal. Because the carrier signal remains during muting, no "pop" or "thud" will be heard. Note that turning this off does **not** turn off the transmitter power—it is simply a way to temporarily mute the transmission of audio signal. If you don't plan on using the AL1 for extended periods, turn it off power by using the power on-off switch (see #7 below). Be sure to mute the audio signal at your external mixer or amplifier before turning the AL1 power on or off, or an audible pop may result.

7: Power switch - Move this switch in the direction of the arrow to turn power to the AL1 on; move it away from the arrow to turn power off. (to conserve battery power, be sure to turn the AL1 off when not in use).

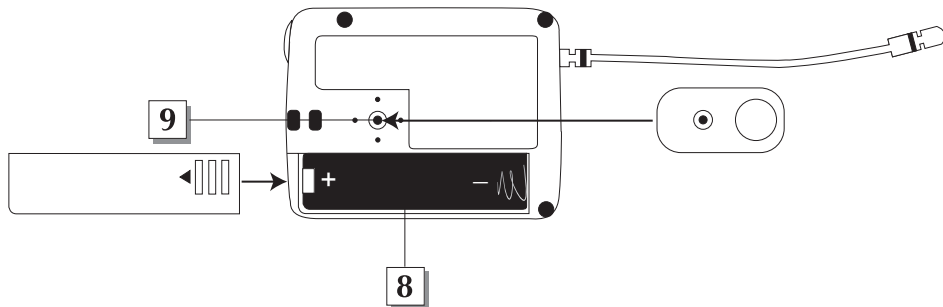

8: Battery compartment - Insert a standard AAA alkaline battery here, being sure to observe the plus and minus polarity markings shown. We recommend the Duracell type battery. Although rechargeable Ni-Cad batteries can be used, they do not supply adequate current for more than four hours. **WARNING:** Do not insert the battery backwards; doing so can cause severe damage to the AL1 and will void your warranty.

9: Clip connector - This clip can be used to fasten the AL1 to a lapel or shirt pocket or to the supplied lanyard. The position of the clip can be rotated to the desired position after loosening its center screw or can be removed entirely by removing the center screw. For more information on positioning the AL1, see the "Setting Up and Using the AirLine System" section on page 17 and Appendix B on page 78 in this manual.

The basic procedure for setting up and using your AirLine System takes only a few minutes:

1. For your AirLine system to work correctly, both the receiver and transmitter must be set to the same channel. Remove all packing materials (save them in case of need for future service) and check to make sure that the supplied receiver and transmitter are set to the same channel (a complete channel plan is printed on the inside back cover of this manual). If these channels do not match, contact your distributor or, if purchased in the United States, Samson Technical Support at 1-800-372-6766.
2. Physically place the receiver where it will be used (the general rule of thumb is to maintain “line of sight” between the receiver and transmitter so that the person using or wearing the transmitter can see the receiver). The CR77 can be rack-mounted if desired (taking a half-rack space), using an optional Samson adapter kit. The UM1 can be mounted to a video camera using the supplied velcro.
3. Extend the receiver antenna(s) and place it (them) in a vertical position. Make sure the Power on-off switch in your transmitter is set to “Off.”
 - 4a. If your system contains an AX1 handheld transmitter, unscrew the bottom section by turning it counterclockwise and then slide it off.
 - 4b. If your system contains an AL1 body pack transmitter, turn it over and slide off the battery door.
5. Place a fresh AAA alkaline battery in the transmitter battery compartment, taking care to observe the polarity markings. If you are using an AX1 transmitter, replace the bottom section by sliding it on and then screwing it back on. If you are using an AL1 transmitter, replace the battery door by sliding it in until it clicks. Whichever transmitter you are using, leave it off for the moment.
6. Make the physical cable connection between the receiver output jack and a mic level audio input of your amplifier or mixer. The balanced XLR jack is preferable, since it will deliver an electromagnetically cleaner signal. If required, both the balanced and unbalanced outputs can be used simultaneously. If your system contains a CR77 or UM1 receiver, be sure to set its Audio Output Level switch correctly (see pages 8 and 10 for details). Leave your amplifier (and/or mixer) off at this time.
7. Turn the Volume, Level or AF Level knob on the receiver completely counterclockwise. Connect the supplied AC adapter to the CR77 receiver and plug it in (the UM1 receiver can also operate off battery power or a 12 volt power supply from a connected video camera), then plug the adapter into any standard AC outlet. Slide the Power switch in the direction of the arrow to turn on the receiver. If system contains a CR77 receiver, its “Power” LED will light steadily red. (Note: The UM1 receiver has no “Power” LED indicator.)

8. Turn on the power to your transmitter (using its Power on-off switch); the “Power/Battery” LED will flash if the battery is sufficiently strong (if it lights steadily, the battery has less than 2 hours of power remaining and should be replaced). If your system contains either a CR77 or UM1 receiver, one of the “A/B Receiver” LEDs will light, showing you whether the (left) “A” or (right) “B” receiver is currently being used. The CR77 / UM1 meter will also indicate the strength of the incoming RF signal.
9. Now it’s time to set the audio levels. Turn on your connected amplifier and/or mixer but keep its volume all the way down. If you are using an AL1 transmitter, make sure that it is unmuted (its Mute switch should be positioned away from the arrow). Then set the Volume, Level or AF Level knob on the receiver fully clockwise; this is unity gain. If you are using an AL1 transmitter with the built-in microphone, note that correct placement is critical to sound quality. We recommend that you place it as shown in the illustrations on this page— unobstructed by clothing and either clipped to a shirt pocket or lapel, or worn around the neck on the supplied lanyard.

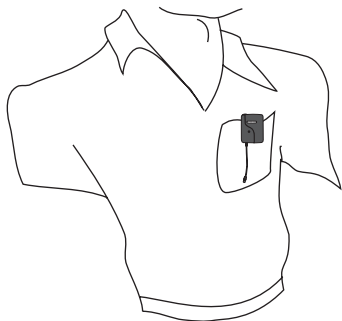

10. Speak or sing into your mic at a normal performance level while slowly raising the volume of your amplifier and/or mixer until the desired level is reached. The UM1 receiver allows you to monitor the transmission signal using standard Walkman-type 30 ohm headphones connected to its headphone jack. Note that **Unidirectional** microphones (mics which pick up signal from just one direction) such as the built-in AL1 electret condenser are less prone to feedback than other types of mics. Any feedback problems you encounter can be minimized by being sure not to use the microphone directly in front of a PA speaker or by using an equalizer to attenuate (reduce) those high- or mid-range frequencies which are causing the feedback "squealing".

11. If you hear distortion at the desired volume level, first check to see whether the "Peak" LED on the receiver is lit. If it is **not** lit, make sure that the gain structure of your audio system is correctly set (consult the owners manual of your mixer and/or amplifier for details). If the red "Peak" LED **is** lit, do the following:

- If you are using an AX1 transmitter, use the supplied plastic screwdriver to turn its Microphone Input Level control (trimpot) slowly counterclockwise (towards the "Min" position) until the distortion disappears.
- If you are using an AL1 transmitter with its internal electret condenser microphone, simply move the microphone further from your mouth. If you are using an AL1 with an external lavalier microphone, use the supplied plastic screwdriver to turn the Gain control (trimpot) slowly counterclockwise until the distortion disappears.

12. Conversely, if you hear a weak, noisy signal at the desired volume level, again make sure that the gain structure of your audio system is correctly set (consult the owners manual of your mixer and/or amplifier for details) and that the Volume control of the receiver is fully clockwise. If it **is** lit and the signal coming from the receiver is still weak and/or noisy, do the following:

- If you are using an AX1 transmitter, use the supplied plastic screwdriver to turn its Microphone Input Level control (trimpot) slowly clockwise (towards the "Max" position) until the signal reaches an acceptable level.
- If you are using an AL1 transmitter with its internal electret condenser microphone, simply position the microphone closer to your mouth. If you are using an AL1 with an external lavalier microphone, use the supplied plastic screwdriver to turn the Gain control (trimpot) slowly clockwise until the signal reaches an acceptable level.

13. Temporarily turn down the level of your mixer/amplifier system and turn off the power to your transmitter, leaving the receiver on. Then restore the previously set level of your mixer/amplifier. With the transmitter off, the receiver output should be totally silent—if it is, skip ahead to the next step. If it isn't (that is, if you hear some noise), you may need to adjust the receiver Squelch control. When the Squelch control is at its minimum setting, the AirLine system always provides maximum range without dropout; however, depending upon the particular environment your system is used in, you may need to reduce that range somewhat in order to eliminate band noise when the transmitter is turned off. To do so, use the provided screwdriver to rotate the Squelch control completely counterclockwise (to the "Min" position), then slowly turn it clockwise until the noise disappears. If no noise is present at any position, leave it at its fully counterclockwise "Min" position (so as to have the greatest overall range available).

14. When first setting up your AirLine System in a new environment, it's always a good idea to do a walkaround in order to make sure that coverage is provided for your entire performance area. Accordingly, turn down the level of your audio system and turn on both the transmitter and receiver. Then, with the transmitter unmuted, restore the level of your audio system and while speaking or singing, walk through the entire area that will need to be covered. As you do so, observe the RF display or meter on the receiver to make sure that it is receiving sufficiently strong RF signal (in the CR77 and UM1 receivers, all segments of the RF Level meter should be lit). Always try to minimize the distance between transmitter and receiver as much as possible so that the strongest possible signal is received from all planned transmission points. In certain environments, it may be desirable to angle the receiver antenna(s) differently from the vertical position. Where extended range coverage is required, the Samson CR77 true diversity receiver (set to the same channel as the transmitter) should be used. For videography applications, the Samson UM1 micro diversity receiver should be used.

If you have followed all the steps above and are experiencing difficulties, contact your local distributor or, if purchased in the United States, call Samson Technical Support (1-800-372-6766) between 9 AM and 5 PM EST.

Specifications

Samson AirLine

CR77 Receiver

Receiving Frequencies	USA 801-805MHz (U1-U6),
Oscillation Type	PLL
De-emphasis	50 msec
IF Frequency	10.7 MHz
A/B Antennas	1/4 Wavelength Rod
In/Out	DC Inlet, Balanced Output, Unbalanced Output
Display (LED)	Receiver A/B (Green), Power On (Red), ARF Level (6 segment) RF Level (6 segment)
Level Control	Audio Level Volume, Squelch Level Control
Operating Temperature	0° C / 50° C
Operating Voltage	12 Volts ±10%
Current Consumption	160 mA (all LED lights illuminate)
Receiving Frequency Range	801 - 805 MHz
Sensitivity	18 dBm (@ THD 2%)
Squelch Sensitivity	0 - 40 dBm (Adjustable)
Selectivity	±150 kHz (AF Out Ratio -60 dB)
T.H.D. (Overall)	1% Max (@AF 1 kHz, RF 46 dBu)
S/N Ratio (Overall)	90 dB (w/IHF-A Filter)
Residual Noise	90 dBv (w/IHF-A Filter)
Band Mute	±40 kHz / ±100 kHz (RF IN: 46 dBu EMF)
AF Frequency Response	50 Hz - 15 kHz (±3 dB overall)
Audio Output Level - Unbalanced	0 dBv
Audio Output Level - Balanced (slide switch selectable)	-20 dBm (Line), -40 dBm (Mic)
Audio Output Impedance - Unbalanced	5 k Ohms
Audio Output Impedance - Balanced	600 Ohms

Samson AirLine Specifications

UM1 Receiver

Receiving Frequencies	USA 801-805MHz (U1-U6), One frequency in Channel Plan
Oscillation Type	Crystal Controlled
Receiving Method	Single Super Heterodyne / True Diversity
De-emphasis	50 msec
IF Frequency	10.7 MHz
Local Frequency	70 MHz Range (79 - 79.5 MHz)
A/B Antennas	1/4 Wavelength Rod
In/Out	5.5 DC Inlet, Balanced Output (Switchcraft TA3F mini-XLR), Unbalanced Output (3.5 mm phone jack), Headphone Output (3.5 mm phone jack) Receiver A/B (Orange), Peak (Red), RF Level / Battery Strength (3 pc) AF output level approx. +4 dB
Display (LED)	Audio Level switch, Squelch volume, Headphone volume, Meter function switch
Peak LED lighting point	0° C / 55° C
Controls	AC adapter DC 6 - 13 Volts, 9 volts battery
Operating Temperature	>60 mA (no signal, all LEDs off)
Operating Voltage	801 - 805 MHz
Current Consumption	17 dBmv \pm 4 dB
Receiving Frequency Range	1% Max (@AF 1 kHz, RF 56 dBuv)
Squelch Sensitivity	95 dB (w/IHF-A Filter)
T.H.D. (Overall)	50 Hz - 15 kHz (\pm 3 dB overall)
Dynamic Range	0 dBv \pm 2 dB (Maximum +9 dBv \pm 3 dB @ 3% THD)
AF Frequency Response	1 k Ohms max. (Unbalanced), 600 Ohms (Balanced)
Audio Output Level	32 Ohms
Audio Output Impedance	12 hours typical
Headphone Output Impedance	
Battery life	

Appendix A: Channel Plan

Samson AirLine

Channel	Frequencies	Channel	Frequencies	Channel	Frequencies
N1	642.375 MHz	U1	801.375 MHz	E1	863.125 MHz
N2	642.875 MHz	U2	801.875 MHz	E2	863.625 MHz
N3	644.125 MHz	U3	803.125 MHz	E3	864.500 MHz
N4	644.750 MHz	U4	803.750 MHz	E4	864.875 MHz
N5	645.500 MHz	U5	804.500 MHz		
N6	645.750 MHz	U6	804.750 MHz		

Appendix B: Attaching the Lanyard to the AL1

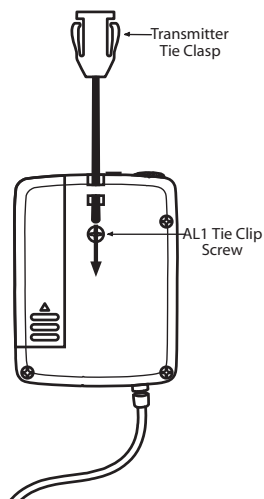

1. Pass the cord from the Transmitter tie clip through the holes on the top rear of the AL1. The clip may have to be rotated (and can be removed) to reveal the exit hole. See page 16 in this manual for further instructions. (For clarity, all the illustrations in this Appendix show the AL1 with the tie clip removed.)

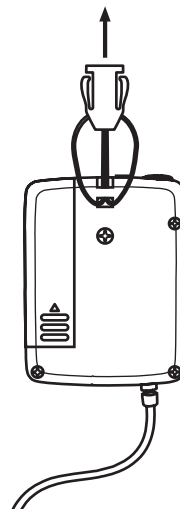

2. Pull the cord all the way through and lift it over the clasp, making a loop. Pull the clasp through the loop taking up the slack.

Appendix B: Attaching the Lanyard to the AL1

Samson AirLine

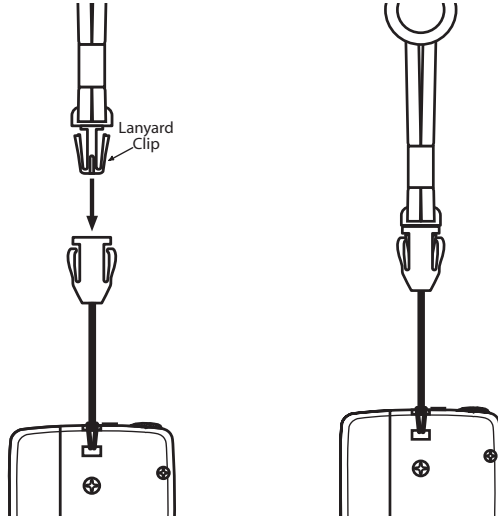

3. Place the lanyard over the head of the person using the transmitter, adjusting the length with the lanyard length adjustment clasp, which should be at the back of the person's neck (refer to the illustration above). Insert the lanyard clip into the AL1 tie clasp until it snaps.

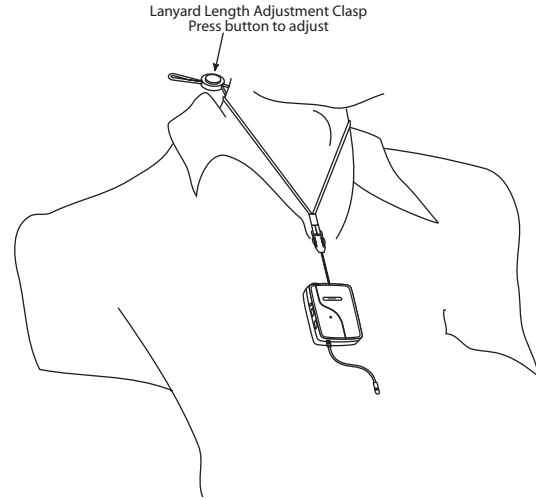

4. The AL1 should rest approximately in the middle of the chest of the person speaking (see illustration above). To increase signal to the mic, adjust the AL1 closer to the person's mouth using the lanyard length adjustment clasp. To temporarily remove the lanyard from the AL1, squeeze the clasp and release the clip.