

PEDAL TIMPANI

TP3300 series

TP3323 / TP3326 / TP3329 / TP3332

Owner's Manual

English

Thank you for purchasing Yamaha Timpani.

Please read through this manual carefully as it contains important information about your instrument's care.

Before using your timpani for the first time be sure to carefully read the instructions on “Initial Preparation” pages 6 and 7.

Contents

Precautions	2
Nomenclature & Lubrication.....	3
Transporting and Setting Up the Timpani.....	4
Setting up the Timpani.....	4
Adjusting Pedal Height	5
Transporting	5
Initial Preparation.....	6
Adjusting the Pitch	8
Head Tuning	8
Pedal Adjustment	9
Tuning Indicator Adjustment	10
Adjusting the Pointer Position.....	10
Replacing the Head	11

PRECAUTIONS

PLEASE READ CAREFULLY BEFORE PROCEEDING

Please keep this manual in a safe and handy place for future reference.

WARNING

Always follow the basic precautions listed below to avoid the possibility of serious injury or even death from damages or other hazards. These precautions include, but are not limited to, the following:

Handling caution

- Never lean on or climb on the instrument. It may overturn resulting in damage or injury.
- Be careful around the instrument. Bumping into it may result in injury or cause it to overturn. Keep small children away from the instrument.
- Never place your fingers or foot into the moving parts or the space under the pedal or base. Serious injury can result if fingers or feet become pinched.

Transporting/Setup

- Never place the timpani on unstable surfaces such as an unstable riser or sloped surface. The timpani may tip over or fall resulting in damage or injury.
- Always lay the instrument on its side before adjusting leg height, or unfolding/folding up the pedal. The instrument can move or fall over resulting in injury.

- When rolling the timpani on its casters, grip it by its frame and move it only on smooth, flat surfaces.
 1. Do not move on sloping, rough, or gravel surfaces.
 2. Do not run with the timpani. It may be difficult to stop the instrument which can cause injury or damage.
- If the timpani must be carried, do so with two or more persons, make sure to grip the timpani by its lugs.

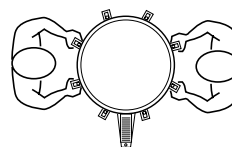

- Except for when moving the instrument, always engage both caster brakes. Not engaging the brakes can result in the instrument falling over or moving resulting in injury.

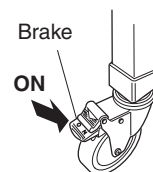

CAUTION

Always follow the basic precautions listed below to avoid the possibility of physical injury to you or others, or damage to the instrument or other property. These precautions include, but are not limited to, the following:

Handling caution

- When operating the pedal, do not touch the hoop, head, or tuning indicator. Fingers may become caught or pinched resulting in injury.

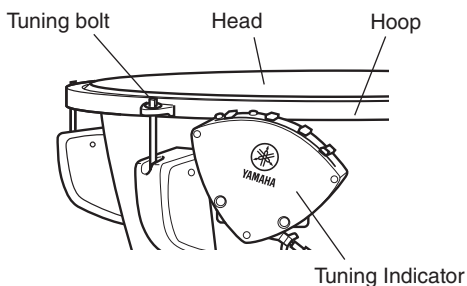

- Replace torn heads as soon as possible. The torn edge of the head is sharp and can cut hands or fingers.
- Do not put your hands inside any of the parts of the timpani (inside the tuning indicator, base, frame, etc.)
- Do not use the mallet for anything besides playing the instrument. Do not allow children strike others with the mallet as it can cause injury or become damaged.

Yamaha cannot be held responsible for damage caused by improper use or modifications to the instrument.

Nomenclature & Lubrication

■ Nomenclature

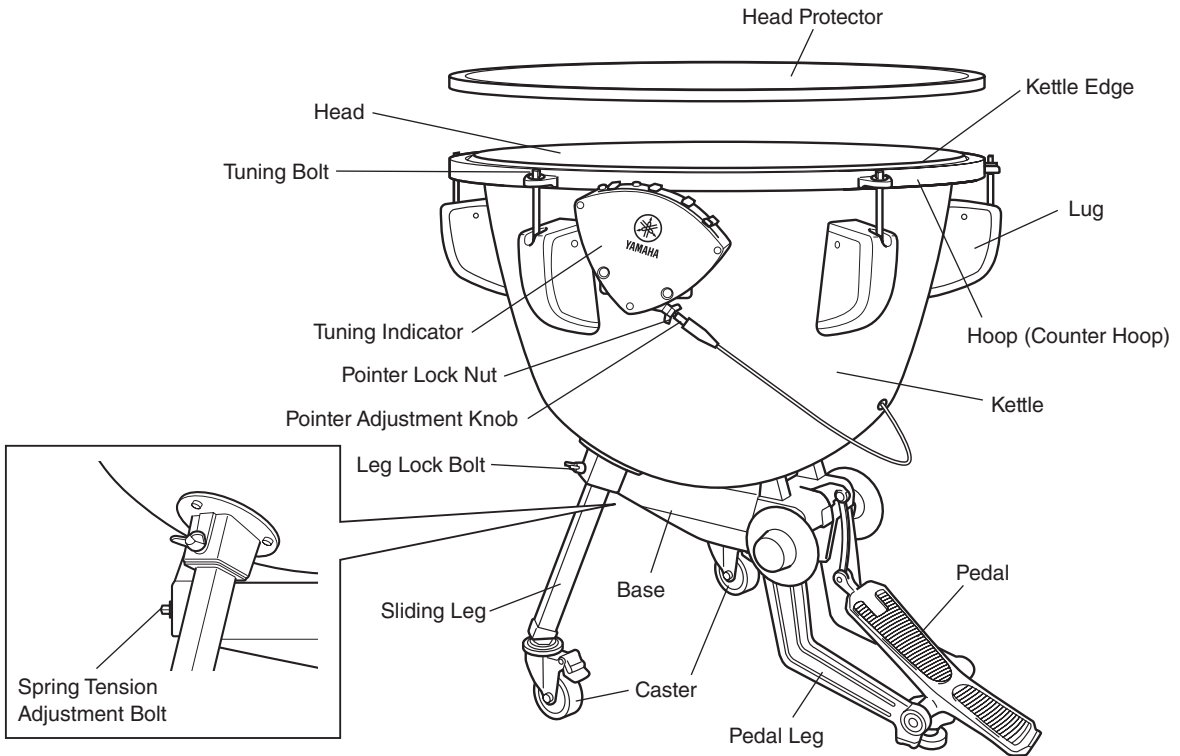

Supplied Accessories

- Tuning Key 1
- Mallets 1 set
- Key/Wrench Holder 1
- Hex Wrench 1

⚠ Caution

Never place your fingers or foot into the moving parts or the space under the pedal or base. Serious injury can result if fingers or feet become pinched.

■ Lubrication

Apply a high quality grease or lubricant to the moving parts indicated by the arrows in the diagram on the right. This should be done at least once a year, or as needed.

- * A spray type lubricant is recommended.
- * Do not touch the lubricated parts.
- * Please use Yamaha care products for daily maintenance.

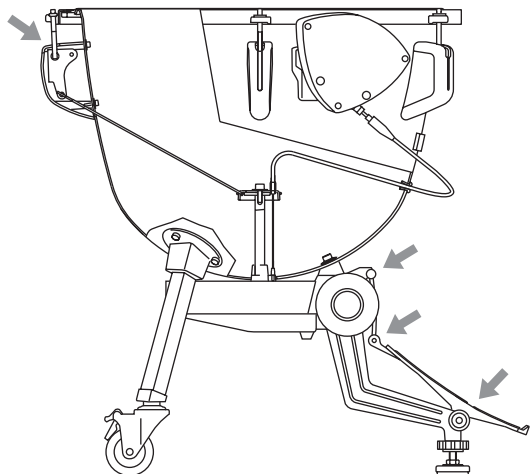

Transporting and Setting Up the Timpani

■ Setting up the Timpani

The TP3300 series features a folding design to reduce the space required to store or transport the timpani. Use the procedure described below when setting up or storing the timpani.

⚠ Caution

Except for when moving the instrument, always make sure that both caster brakes are engaged.

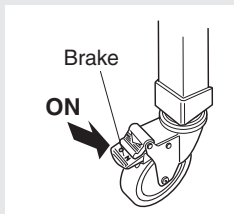

Playing the instrument without the brakes engaged can result in the instrument moving about or unwanted noise. Also, tuning or adjusting the pedal without the brakes engaged is very dangerous. The instrument can unexpectedly move or fall over resulting in injury.

⚠ Caution

Never place your fingers or foot into the moving parts or the space under the pedal or base.

Serious injury can result if fingers or feet become pinched.

1 Lay the instrument on the floor as shown in the diagram below. We recommend placing a cloth on the floor to protect both the floor and instrument from damage.

* The caster brakes **1** on both legs should be in the "ON" position.

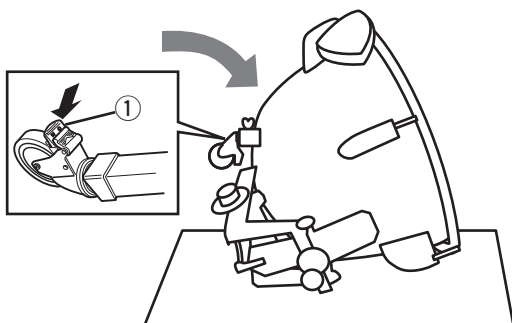

2 Loosen the leg lock bolt **2**, extend the sliding leg **3** to the desired length **3**, then tighten the leg lock bolt **2**. Use the marks **4** on the sliding leg as a guide.

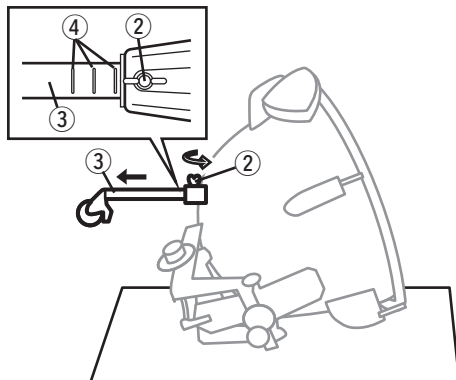

3 Turn the instrument over and extend the other sliding leg using the same procedure.

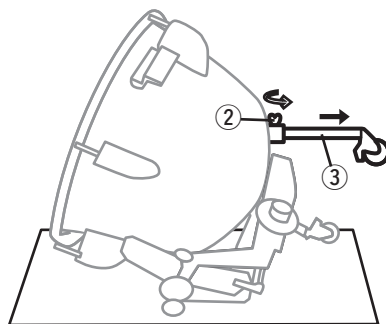

4 Position the instrument as shown in the diagram below. Using both hands, turn the lock bolts **5** in the direction marked with the arrows until the narrow section of the lock bolt shaft **6** is visible.

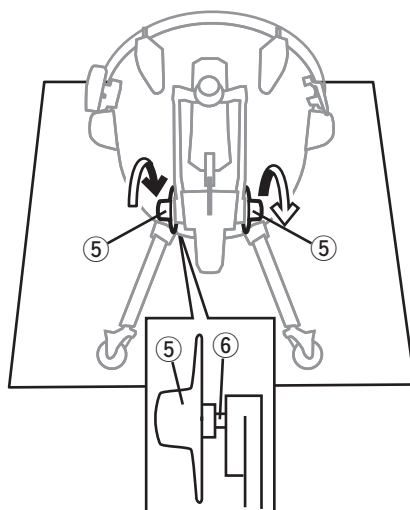

- 5** Unfold the pedal unit (7) until the unit stops, then turn both lock bolts (5) in the opposite direction described in step 4 until tight.

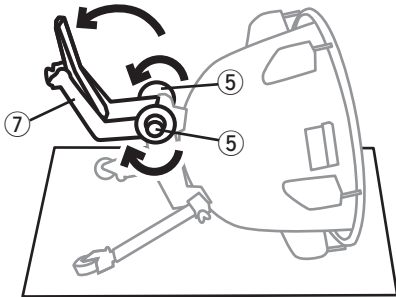

- 6** Hold the instrument firmly and return it to an up-right position.

When putting the instrument away, reverse the order of the previous procedure.

⚠ Caution

Make sure your fingers do not get pinched between the pedal and kettle when folding the pedal or pedal base. Serious injury can result if fingers or feet become pinched.

■ Adjusting Pedal Height

After laying the instrument on its side, loosen the stopper and use the height adjustment screw to adjust pedal height. After determining the height, tighten the stopper to secure.

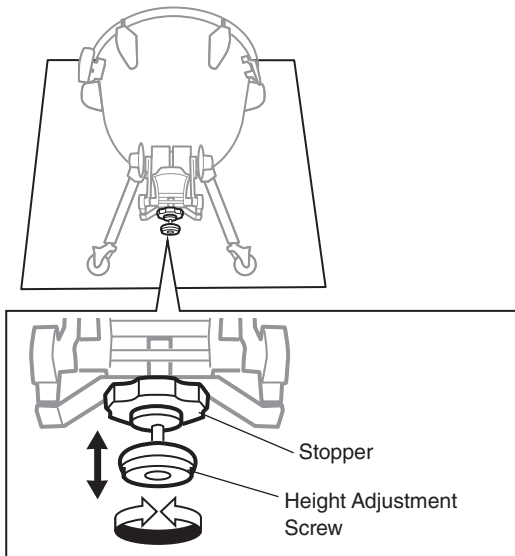

■ Transporting

When moving the timpani over a distance, such as from room to room, make sure that the instrument is carried by at least two persons.

The casters on the sliding legs are convenient when moving the timpani short distances over smooth surfaces such as when changing stage setups, etc. To move the timpani, unlock the casters, then slightly lift the timpani by the lugs so that the pedal frame is off of the ground and slowly move the timpani forward or backward as shown in the illustration below.

Be careful not to damage the legs while moving the timpani.

- * **Damage may occur if the timpani is dropped or falls from a high place.**

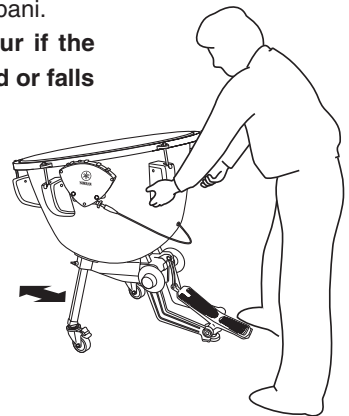

● Attaching the Key/Wrench Holder

Insert the key/wrench holder into the mounting bracket on the side of the timpani opposite of the tuning indicator. Once installed it can be used to hold the tuning key and allen wrench.

- * **Peel off the protective paper on the adhesive tape on the backside of the holder, and firmly attach the holder to the mounting bracket.**

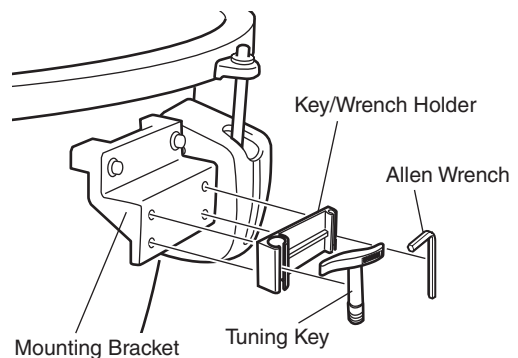

Initial Preparation

Your Yamaha timpani is equipped with a plastic head carefully mounted and adjusted at the factory. However, new heads tend to stretch during shipping and storage, so it may be necessary to re-tune the instrument before using. Please perform the following steps to check and, if necessary, readjust your instrument.

1 The area between the kettle edge and the inner circle of the counter hoop is called the collar. Please make sure that the width of this collar is uniform, as shown in the illustration titled “Correct.”

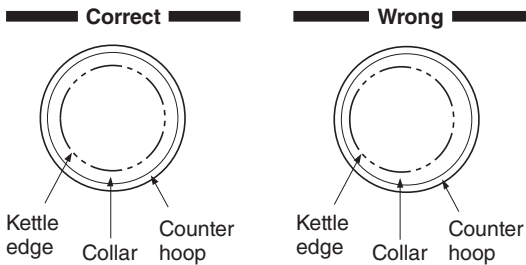

If collar width is not uniform, fully depress the heel end of the pedal. While holding the pedal in this position, realign the head and hoop as shown in the “Correct” illustration.

⚠ Caution

Never place your fingers or foot into the moving parts or the space under the pedal or base.

Serious injury can result if fingers or feet become pinched.

2 Fully depress the heel end of the pedal. While holding the pedal in this position, use the supplied tuning key to tighten the tuning bolts one by one $\frac{1}{4}$ of a turn (90°) in the order shown in the illustration below.

It is very important that all tuning bolts be turned the same amount.

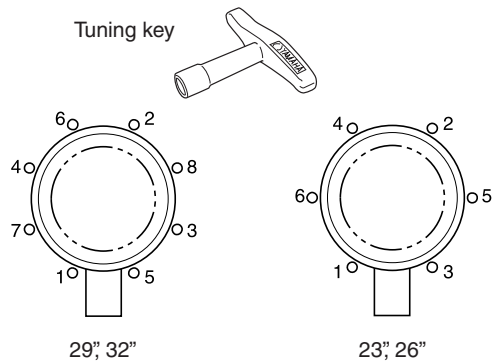
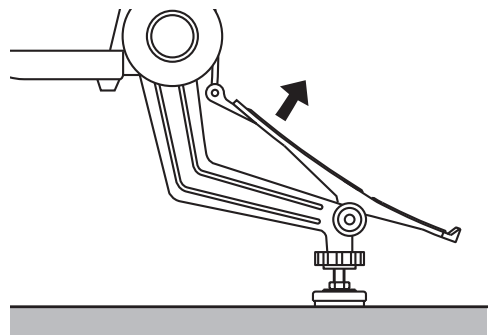

3 Take your foot off the pedal.

- **Heel still moves up**
→ Repeat steps **2** through **3**.
- **Heel stays down**
→ Go to step **4**.

4 Put your foot on the pedal and fully depress it in either direction (toe and heel).

- **Toe and heel feel equal**

→ Go to step **5**.

- **Heel feels lighter than toe (*1)**

→ Head is too tight and should be loosened. Keeping the heel of the pedal depressed, loosen the first tuning bolt by 1/2 turn and then re-tighten it by 1/4 of a turn. Perform this operation for all other tuning bolts in the order shown in step **2**.

Repeat this procedure until proper head tension is obtained then go to step **5**.

- **Heel feels heavier than toe**

→ Head is not tight enough. Keeping the heel end of the pedal depressed, tighten each of the tuning bolts another 1/8 (45°) turn in the same order as in step **3**.

Repeat this procedure until proper head tension is obtained then go to step **5**.

5 Move the pedal into an intermediate position, as shown below, and remove your foot from the pedal. Confirm that the pedal stays in this position and does not move.

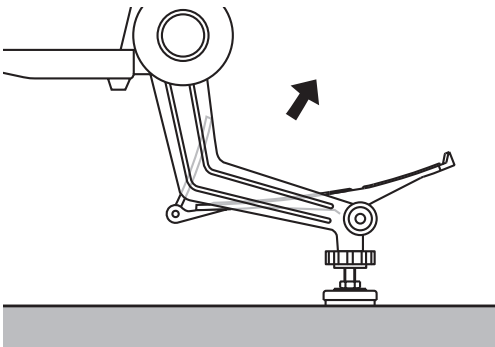

- If the pedal remains in the same position adjustment is complete. Go to step **6**.

- If the toe of the pedal moves downward

→ The head is too tight. Loosen the head using the procedure described in step **4** (*1).

6 Tap the head lightly with the mallet. The standard striking point is shown below.

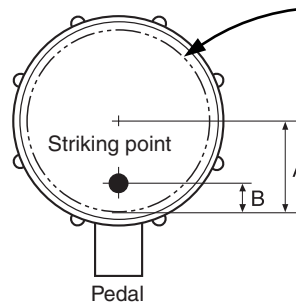

The standard striking point lies at distance B from the kettle edge, which corresponds approximately to 1/4 to 1/3 of the distance between the kettle edge and the center of the head.

As the toe of the pedal is pressed down, the pitch is raised.

For details on precise tuning refer to “**Adjusting the Pitch**” on the following page.

As the head will stretch over time, readjustment should be performed periodically (starting with step **4).**

Adjusting the Pitch

When using the timpani for the first time, be sure to set it up according to the instructions of “Initial Preparation” on pages 6 and 7.

■ Head Tuning

1 Tuning is adjusted on the lowest note of the timpani. For this reason, the heel of the pedal must stay fully lowered during the tuning procedure.

The pitch of the lowest note (and the tonal range) depends on the size of your timpani. For example, as shown in the chart below, the lowest sound of a 26" timpani should be tuned to A. When tuned properly, your Yamaha timpani will play throughout its full tonal range with balanced tension in the paddle.

■ Standard Tonal Ranges for Yamaha Timpani

32" (81cm) 29" (74cm) 26" (66cm) 23" (58cm)

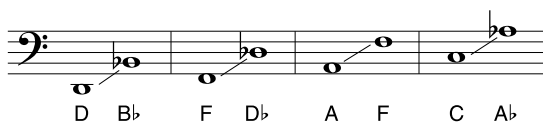

Keep the heel of the pedal fully lowered during the tuning procedure (steps 2 through 7 below) if not specified otherwise.

2 Strike the head and check the sound. The standard striking point is shown below.

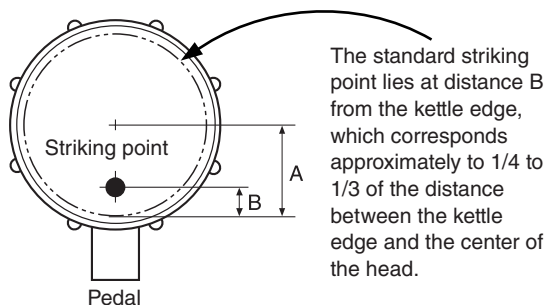

• **Sound is lower than the tuning note**

→ Go to step 3.

• **Sound is higher than the tuning note**

→ Loosen the tuning bolts by an equal amount in the order shown in the figure of step 5 on page 7.

When loosening the tuning bolts, always loosen them by double the desired amount, and then return (re-tighten) them by half. When the sound lies within 1 halfnote below the desired pitch after loosening the tuning bolts (repeatedly, if necessary), proceed with step 3.

3 Lightly strike the head with the mallet about 2 inches (5 cm) from the kettle edge at each tuning bolt. Check which tuning bolt has the highest sound.

• **Pitch of the highest sound is higher than the tuning note (*2)**

→ Loosen the corresponding tuning bolt by about 1/16 to 1/8 of a turn. First loosen the bolt by double the desired amount, and then return (re-tighten) it by half. After loosening the tuning bolt, repeat from the beginning of step 3.

• **Pitch of the highest sound is lower than the tuning note**

→ Go to step 4.

4 Tighten the other bolts little by little (by about 1/16 to 1/8 of a turn) until the sounds at the corresponding striking points match the pitch of the highest sound. Please note that tightening one bolt also raises the pitch at neighboring and opposite tuning bolts. Thus, after tightening the tuning bolt with the lowest sound, again check the pitch at the other tuning bolts before tightening the tuning bolt with the next lowest pitch. While alternately tightening the other bolts, do not touch the tuning bolt with the highest pitch (reference pitch).

5 Loosen all over-tightened bolts according to the procedure described in step **3** (*2). When the pitch is approximately the same at each bolt, repeatedly depress the toe and heel of the pedal several times.

6 Repeat steps **3** through **5** until the pitch at each bolt is exactly the same.

7 Check the sound by striking the head as described in step **2**.

- **Sound is lower than the tuning note**

→ Tune the instrument by tightening all tuning bolts by an equal amount (max. 1/16 of a turn).

- **Sound is higher than the tuning note**

→ Tune the instrument by loosening all tuning bolts by an equal amount (max. 1/16 of a turn) according to the procedure described in step **3**.

8 Operate the pedal as described in step **5**. If the pitch does not change, the instrument is tuned properly.

(If the pitch changes, repeat from step **7**.)

The instrument is now tuned to the lowest sound (note) of its tonal range. Depress the toe of the pedal to change to a higher pitch (note).

9 After tuning, perform ■ **Pedal Adjustment** and then ■ **Tuning Indicator Adjustment**.

■ Pedal Adjustment

After depressing the toe and heel of the pedal, turn the spring tension adjustment bolt as described below.

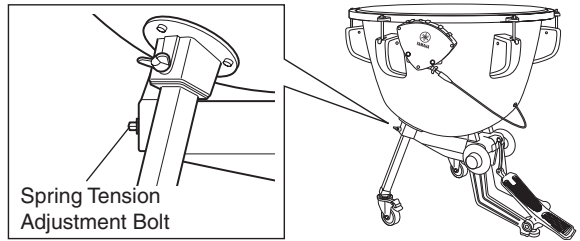

- **Heel moves up when releasing the foot from the pedal after depressing the heel, or the heel feels heavier than the toe.**

→ Turn the spring tension adjustment bolt to the left (counterclockwise).

- **Toe moves up when releasing the foot from the pedal after depressing the toe, or the toe feels heavier than the heel**

→ Turn the spring tension adjustment bolt to the right (clockwise).

Use the supplied tuning key to turn the spring adjustment bolt. Do not turn too many full rotations at once, and re-check the adjustment every 2 turns by pressing the toe and heel of the pedal.

⚠ Caution

Never place your fingers or foot into the moving parts or the space under the pedal or base. Serious injury can result if fingers or feet become pinched.

Note

Do not loosen the spring tension adjustment bolt by more than 3 rotations at a time, as the toe of the pedal tends to drop abruptly after a specific point.

● Pedal balance spring mechanism

Your Yamaha timpani is equipped with a unique pedal balance spring mechanism (a coil spring counteracting the tension of the head) which allows you to freely change the pitch (note) of the instrument. When the pedal is moved, the pitch of the head will change, and the balance spring ensures that the pedal angle (pitch) will not change when you remove your foot from the pedal.

Tuning Indicator Adjustment

The tuning indicator shows where to set the pedal for each note. After tuning the instrument, you must set each note on the indicator to its proper position.

1 After you have tuned your timpani to the lowest note of its tonal range, make sure that the pointer is located within 2~3 mm from the pedal-side end of the indicator rail.

* If not, refer to “Adjusting the Pointer Position”.

2 Slide the lowest note of the indicator (“C” in the case of a 23” timpani*) to the position where its center line coincides with the pointer.

* “Standard Tonal Ranges for Yamaha Timpani” on page 8.

3 Tune the instrument to the next higher pitch (note) by moving the pedal, and then slide the corresponding note on the rail to the respective pointer position. Repeat for each remaining note.

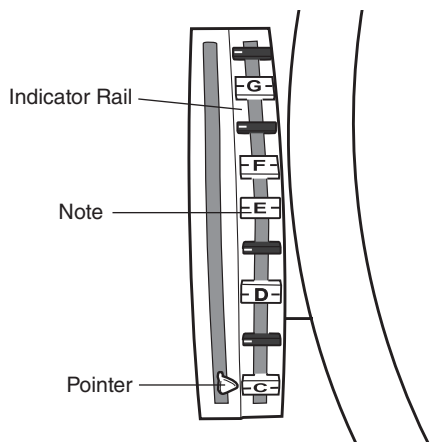

■ Adjusting the Pointer Position

First loosen the pointer lock nut and then turn the adjuster as follows:

• **Pointer is located beyond the lower rail end when the heel of the pedal is lowered fully (lowest note).**

→ Turn the adjuster to the left (counter clockwise) until the pointer is aligned with the lowest note of the indicator.

• **Pointer moves beyond the upper rail end before the toe of the pedal reaches the end of its stroke, or Pointer does not reach the lower rail end when the heel of the pedal is lowered fully (lowest sound)**

→ Turn the adjuster to the right (clockwise) to correct the pointer position as required.

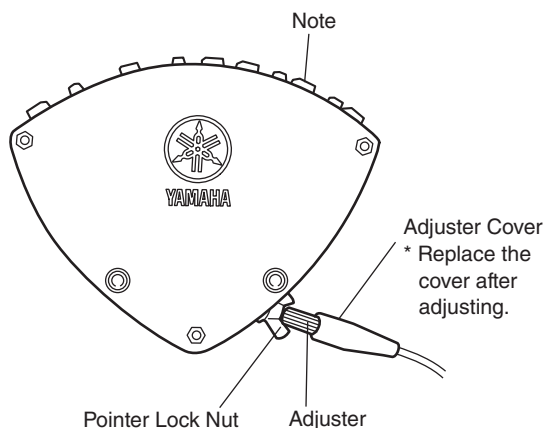

● Relocating the Tuning Indicator

The timpani is shipped with a universal style tuning indicator already attached however, the tuning indicator can be relocated for German style tuning.

Using the supplied hex wrench, remove the two bolts holding the tuning indicator in place as shown in the diagram right, then slide the bolts through the holes on the tuning indicator from the opposite side. In either position, make sure that the note indicator bridge is easily viewable.

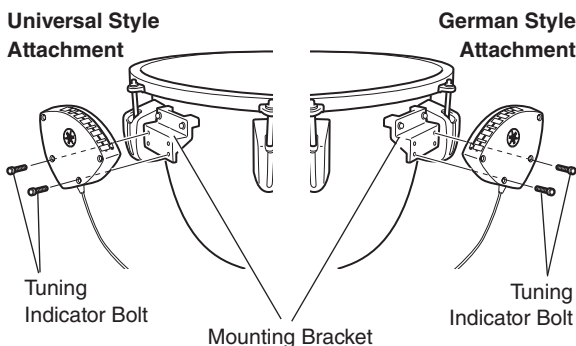

Replacing the Head

- 1 Loosen tuning bolts alternately and remove the bolts.

Caution

Do not touch the pedal when loosening the tuning bolts (loosening the head). Also, never place your fingers or foot into space under the pedal, around its base, or its moving parts. Changes in spring tension can cause the pedal to suddenly move, posing a great danger.

We recommend that you mark the pedal side of the hoop with a piece of tape, etc. so that the hoop can be reattached to the same position.

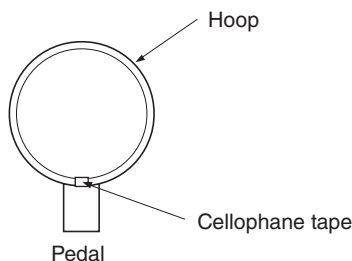

- 2 Remove the hoop and head together. Be careful not to lose any of the tuning bolts and prevent dust from adhering to them. Also, avoid touching the tuning bolt threads, as they are greased.
 - * Be careful not to make any scratches in the edge tape attached to the kettle's edge.

- 3 Place the new head with the hoop on the kettle. When using a Yamaha timpani head, make sure its Yamaha logo is on the side opposite the pedal. The hoop must be re-mounted in the same position as marked with cellophane tape in step 2. In the proper order, tighten the tuning bolts alternately by hand until the head is tensioned slightly. At this time, make sure that the head and hoop are centered on the kettle. Tighten each tuning bolt an additional 1/4 of a turn using the timpani key. Repeat at least 4 times.

- 4 Adjust the timpani as described on page 6 “Initial Preparation” starting with step 2. For precise tuning, refer to the section “Adjusting the Pitch” on page 8.

Interval for head replacement

When the head is slightly tensioned and its surface looks wavy or shows dents, it is time to replace the head with a new one.

The maximum head life normally is approximately 2 years and depends on the frequency and duration of use. However, the head should always be replaced before the sound quality deteriorates dramatically. If a head is left on and used more than two years, the following problems may occur:

- It may become impossible to tune the head to the proper pitch range.
- It may become impossible to balance the pedal.
- The main unit mechanisms themselves may become damaged.

We recommend replacing the head every year.

