

Kramer Electronics Ltd.



USER MANUAL

ELECTRONIC SWITCHERS

Models:

VS-55, VS-55A, VS-55V, VS-55YC

IMPORTANT: Before proceeding, please read paragraph entitled
"Unpacking and Contents"

Contents

1	INTRODUCTION	2
1.1	A Word on Video Switchers	2
1.2	Factors Affecting Quality of Results	2
2	SPECIFICATIONS	3
3	HOW DO I GET STARTED?	4
4	UNPACKING AND CONTENTS	4
4.1	Optional Accessories	4
5	ELECTRONIC SWITCHERS	5
5.1	Getting to Know Your VS-55 Switcher	5
5.2	Getting to Know Your VS-55A Switcher	6
5.3	Getting to Know Your VS-55V Switcher	7
5.4	Getting to Know Your VS-55YC Switcher	8
6	INSTALLATION	9
6.1	Rack Mounting	9
7	CONNECTING TO VIDEO OR AUDIO DEVICES	9
8	USING THE SWITCHERS	9
8.1	Connecting and Controlling the Switchers	9
8.2	Extending a Switcher	10
8.3	Parallel Signal Switching	11
8.4	Remote Controlling the Switchers	12
9	TAKING CARE OF YOUR MACHINE	12
10	TROUBLESHOOTING	13
10.1	Video Signal	13
10.2	Audio Signal	13

Figures

FIGURE 1:	VS-55 FRONT AND REAR PANEL FEATURES	5
FIGURE 2:	VS-55A FRONT AND REAR PANEL FEATURES	6
FIGURE 3:	VS-55V FRONT AND REAR PANEL FEATURES	7
FIGURE 4:	VS-55YC FRONT AND REAR PANEL FEATURES	8
FIGURE 5:	EXTENDING A SWITCHER – ADDING INPUTS	10
FIGURE 6:	PARALLEL SIGNAL SWITCHING	11

Tables

TABLE 1:	VS-55 FRONT AND REAR PANEL FEATURES	5
TABLE 2:	VS-55A FRONT AND REAR PANEL FEATURES	6
TABLE 3:	VS-55V FRONT AND REAR PANEL FEATURES	7
TABLE 4:	VS-55YC FRONT AND REAR PANEL FEATURES	8
TABLE 5:	PIN CONFIGURATION OF THE “LINK” CONNECTOR	12

1 INTRODUCTION

Congratulations on your purchase of this Kramer Switcher. Since 1981 Kramer has been dedicated to the development and manufacture of high quality video/audio equipment. The Kramer line has become an integral part of many of the best production and presentation facilities around the world. In recent years, Kramer has redesigned and upgraded most of the line, making the best even better. Kramer's line of professional video/audio electronics is one of the most versatile and complete available, and is a true leader in terms of quality, workmanship, price/performance ratio and innovation. In addition to the Kramer line of high quality switchers, such as the one you have just purchased, Kramer also offers a full line of high quality distribution amplifiers, processors, interfaces, controllers and computer-related products.

This manual includes configuration, operation and option information for the following Kramer switchers. They are grouped here as they are similar in operation and features.

- **VS-55 – 5x1 Dual Wideband Switcher**
- **VS-55A – 5x1 Stereo Audio Switcher**
- **VS-55V – 5x1 Video Switcher**
- **VS-55YC – 5x1 s-Video Switcher**

1.1 A Word on Video Switchers

Switchers route one or more sources signals to one or more users. They vary in the number of inputs, programming capability, number of outputs, operating format (audio, composite video, component, etc.) and switching method (i.e., whether they switch during the vertical interval or not, whether they are electronic, RS-232 or mechanically controlled). A switcher usually switches between several sources (inputs) and one or more acceptors (outputs). A switcher that allows several inputs to be connected to several outputs simultaneously is called a matrix switcher. Switchers may be of the electronic or mechanical type. Most matrices are of the active electronic type, with many crosspoints. Vertical Interval Switching, frequently used in video, ensures that the transition from one video source to another is smooth and without interference. The switchers described in this manual are electronic switchers, have full specifications, various control options and expandability and can be rack-mounted using special adapters. Most of them offer a simple and economic solution for every video, audio or wideband-signal application.

1.2 Factors Affecting Quality of Results

There are many factors affecting the quality of results when signals are transmitted from a source to an acceptor:

- **Connection cables** - Low quality cables are susceptible to interference; they degrade signal quality due to poor matching and cause elevated noise levels. They should therefore be of the best quality.
- **Sockets and connectors of the sources and acceptors** - So often ignored, they should be of highest quality, since "Zero Ohm" connection resistance is the objective. Sockets and connectors also must match the required impedance (75ohm in video). Cheap, low quality connectors tend to rust, thus causing breaks in the signal path.
- **Amplifying circuitry** - Must have quality performance when high linearity, low distortion and low noise operation are the desired end result.
- **Distance between sources and acceptors** - Plays a major role in the result. For long distances (over 15 meters) between sources and acceptors, special measures should be taken in order to avoid cable losses. These include using higher quality cables or adding line amplifiers.
- **Interference from neighboring electrical appliances** - These can have an adverse effect on signal quality. Balanced audio lines are less prone to interference, but unbalanced audio should be installed far from any mains power cables, electric motors, transmitters, etc. even when the cables are shielded.



Caution – No operator-serviceable parts inside unit.

Warning – Use only the Kramer Electronics input power wall adapter that is provided with this unit¹.

Warning – Disconnect power and unplug unit from wall before installing or removing device or servicing unit.

¹ For example: model number AD2512C, part number 2535-000251



2 SPECIFICATIONS

	VS-55	VS-55A	VS-55V	VS-55YC
Configuration	Dual 5x1	5x1	5x1	5x1
Inputs	5 dual signals, on RCA connectors	5 stereo audio, 1Vpp/50 k on RCAs	5 Composite / single Component, 1Vpp/75ohm on BNCs	5 s-Video (Y/C) 1Vpp/75ohm (Y), 0.3Vpp/75ohm (C) on 4P connectors
Outputs	1 dual signal, on RCA connectors LINK connector (DB9), EXT connector (RCA)	1 stereo audio, 1Vpp/100 ohms on RCAs LINK connector (DB9), EXT connector (RCA)	1 Composite / single Component, 1Vpp/75ohm on a BNC LINK connector (DB9), EXT connector (RCA)	1 s-Video (Y/C) 1Vpp/75ohm (Y), 0.3Vpp/75ohm (C) on a 4P connector LINK connector (DB9), EXT connector (RCA)
Switching system	Electromechanical	Electromechanical	Electromechanical	Electromechanical
Vertical Interval	NO	NO	YES	YES
Bandwidth	270 MHz	100 kHz	150 MHz	120 MHz (Y)
Control	5 front-panel touch switches, remote contact closure	5 front-panel touch switches, remote contact closure	5 front-panel touch switches, remote contact closure	5 front-panel touch switches, remote contact closure
DIFF. GAIN	NA	NA	0.88%	0.03%
DIFF. PHASE	NA	NA	0.35 Deg.	0.07 Deg.
THD	NA	<0.08%	NA	NA
S/N Ratio	NA	>78 dB	>73 dB	>78 dB (Y)
Max. Output	Up to 60 V	3 Vpp / 100 ohm	>1.6 Vpp/75 ohms	1.4 Vpp/75 ohms, (Y)
Accessories	12 V Power Supply	12 V Power Supply	12 V Power Supply	12 V Power Supply
Dimensions (W, D, H)	16.5 x 12 x 4.5 (cm) (6.5" x 4.7" x 1.8")	16.5 x 12 x 4.5 (cm) (6.5" x 4.7" x 1.8")	16.5 x 12 x 4.5 (cm) (6.5" x 4.7" x 1.8")	16.5 x 12 x 4.5 (cm) (6.5" x 4.7" x 1.8")
Power Supply	12 VDC, 100 mA	12 VDC, 100 mA	12 VDC, 100 mA	12 VDC, 115 mA
Weight	0.62kg. (1.4 lbs.) Approx.	0.62kg. (1.4 lbs.) Approx.	0.66 kg. (1.46 lbs.) Approx.	0.64 kg. (1.4 lbs.) Approx.



3 HOW DO I GET STARTED?

The fastest way to get started is to take your time and do everything right the first time. Taking 15 minutes to read the manual may save you a few hours later. You don't even have to read the whole manual. If a section doesn't apply to you, you don't have to spend your time reading it.

4 UNPACKING AND CONTENTS

The items contained in your Kramer accessory package are listed below. Please save the original box and packaging materials for possible future transportation and shipment.

- **Switcher**
- **User Manual**
- **Kramer Concise Product Catalog**
- **12 V DC Power Supply**
- **4 Rubber Feet**

4.1 Optional Accessories

The following accessories, which are available from Kramer, can enhance implementation of your switcher. For information regarding cables and additional accessories, contact your Kramer dealer.

- **Rack Adapter (RK-50R)** - Used to install smaller machines in a standard 1 or 2 U rack. One or more machines may be installed on each adapter.
- **BNC "Y" Connector** - Used for looping purposes and splits the incoming signal to enable connection of an additional machine.
- **Termination Plug** - Used to terminate the line to 75ohm for proper matching.
- **A video or s-Video distribution amplifier** – such as the Kramer VM-3V, VM-50V, VM-10ARII, VM-20ARII (video), VM-3S, VM-50YC, VM-5YC, VM-10YC (s-Video) for distributing the output signals to several acceptors simultaneously.
- **An Audio Distribution Amplifier** – such as Kramer VM-50A, VM-80A etc. for distributing the output signals to several acceptors simultaneously.
- **A line amplifier** – such as Kramer VM-9S, 104L (video), VM-9YC, 103YC (s-Video), for transmitting signals over long distances, minimizing cable losses.
- **VIDEO TESTER** - A new, unique, patented, indispensable tool for the video professional, the Video Tester is used to test a video path leading to/from an amplifier. By pressing only one touch switch it can trace missing signals, distinguish between good and jittery (VCR sourced) signals, and identify the presence of good signals. Whenever a video signal is missing- because of bad connections, cable breaks or faulty sources- the Video Tester is all you need.

5 ELECTRONIC SWITCHERS

This section describes the controls and connections of your switcher. Understanding all the controls and connections helps you realize the full power of your switcher.

5.1 Getting to Know Your VS-55 Switcher

The Kramer **VS-55** is a high quality, dual wideband switcher for use with any set of dual signals such as stereo audio, s-Video (Y/C), balanced audio, etc. It allows one of up to five dual sources to be routed to one dual output. Since the signal path is passive, using high quality relays, the **VS-55** can also operate in the opposite direction, allowing one source to be routed to any one of five destinations.

The **VS-55** also provides an EXT connector, which allows several units to be combined to form larger switching systems. For example, two units will form a 10x1, three will form a 15x1, etc. A 12VDC power supply is included for typical operation, but the optional model **VA-50P** can power up to six Kramer devices requiring 12VDC. All Kramer **VM-50** and **VS-55** series products can be rack-mounted using the model **RK-50R** kit that holds two units in one or two vertical rack spaces.

Panel features of the **VS-55** are described in Figure 1 and Table 1.

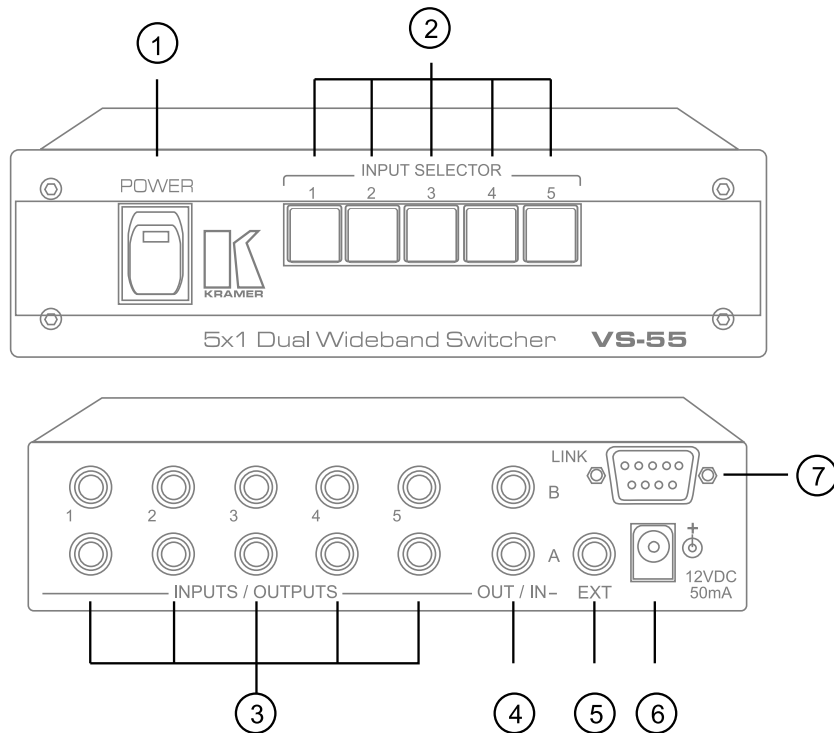

Figure 1: VS-55 Front and Rear Panel Features

Table 1: VS-55 Front and Rear Panel Features

No.	Feature	Function
1.	POWER Switch	Supplies power to the machine
2.	INPUT Selector Switches	Illuminated touch-button switches for selecting the desired input.
3.	INPUTS/OUTPUTS Sockets	5 Dual RCA connectors that can serve as inputs or outputs.
4.	OUT/IN Socket	1 Dual RCA connector that can serve as output or input.
5.	EXT Socket	A single RCA socket that is used for switcher extension
6.	12VDC Socket	For connecting a DC power supply to the machine
7.	LINK Socket	A 9-pin D-sub female socket for parallel operation of several machines or for contact closure remote control.



5.2 Getting to Know Your VS-55A Switcher

The Kramer **VS-55A** is a high performance 5x1 switcher for stereo audio signals. Using RCA connectors, one of up to five sources can be routed to an output. The **VS-55A** can be used as an independent audio switcher, but is also designed to easily link with other **VS-55** series Kramer switchers such as the **VS-55V** for composite video, or the **VS-55YC** for s-Video, to form “audio-follow-video” systems.

The **VS-55A** also provides an EXT connector, which allows several units to be combined to form larger switching systems. For example, two units will form a 10x1, three will form a 15x1, etc. A 12VDC-power supply is included for typical operation, but the optional model **VA-50P** can power up to six Kramer devices requiring 12VDC. All Kramer **VM-50** and **VS-55** series products can be rack-mounted using the model **RK-50R** rack kit which holds two units in one or two vertical rack spaces. Panel features of the **VS-55A** are described in Figure 2 and Table 2.

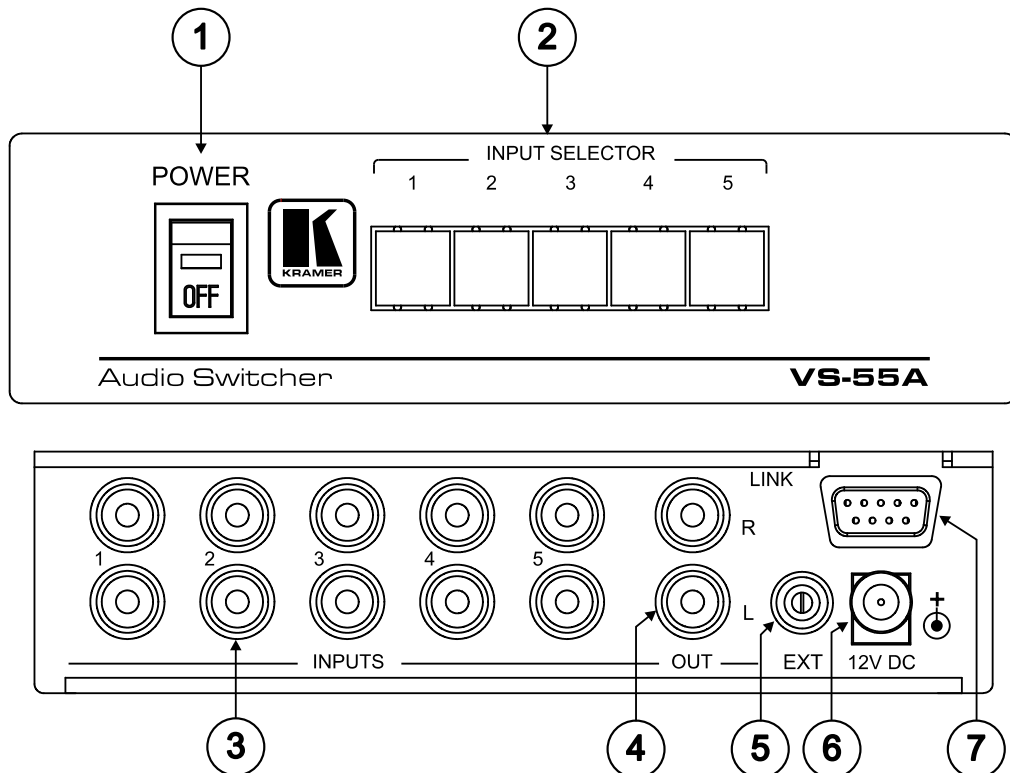

Figure 2: VS-55A Front and Rear Panel Features

Table 2: VS-55A Front and Rear Panel Features

No.	Feature	Function
1.	POWER Switch	Supplies power to the machine
2.	INPUT Selector Switches	Illuminated touch-button switches for selecting the desired input.
3.	INPUTS Sockets	5 Dual RCA connectors that serve as the inputs to the machine.
4.	OUT Socket	1 Dual RCA connector that serves as the output of the machine.
5.	EXT Socket	A single RCA socket that is used for switcher extension
6.	12VDC Socket	For connecting a DC power supply to the machine
7.	LINK Socket	A 9-pin D-sub female socket for parallel operation of several machines or for contact closure remote control.

5.3 Getting to Know Your VS-55V Switcher

The Kramer **VS-55V** is a high performance 5x1 vertical interval switcher designed for composite video signals. One of up to five sources can be routed to one monitor, projector, or other receiving device. Since it switches during the vertical interval, transitions are glitch-free when sources share common reference sync. The **LINK** connector is designed to allow the use of a **VS-55A** to form “audio-follow-video” systems. The **VS-55V** also provides an **EXT** connector, which allows several units to be combined to form larger switching systems. For example, two units will form a 10x1, three will form a 15x1, etc. A 12VDC power supply is included for typical operation but the optional model **VA-50P** can power up to six Kramer devices requiring 12VDC. All Kramer **VM-50** and **VS-55** series products can be rack-mounted using the model **RK-50R** kit that holds two units in one or two vertical rack spaces. Panel features of the **VS-55V** are described in Figure 3 and Table 3.

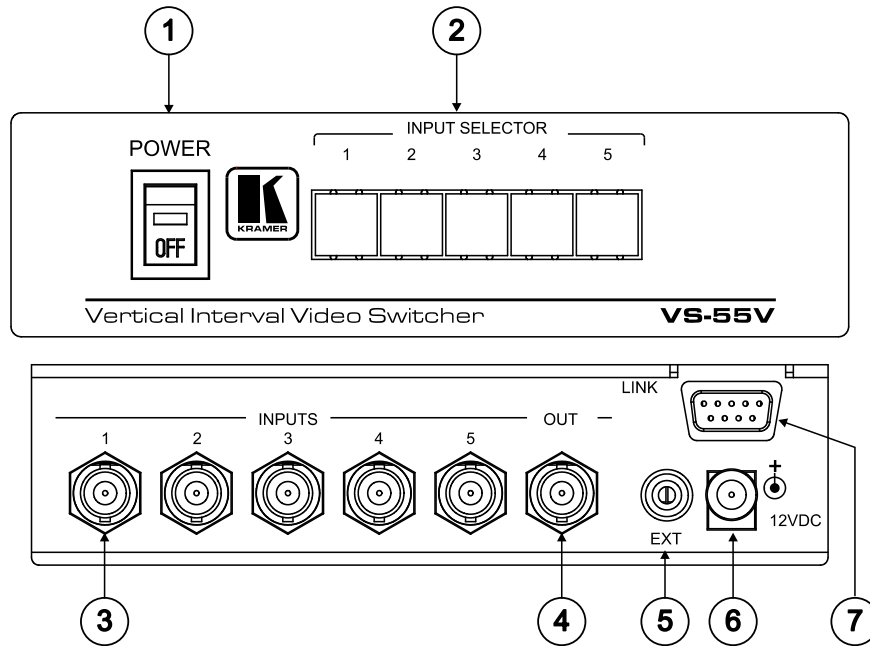

Figure 3: VS-55V Front and Rear Panel Features

Table 3: VS-55V Front and Rear Panel Features

No.	Feature	Function
1.	POWER Switch	Supplies power to the machine
2.	INPUT Selector Switches	Illuminated touch-button switches for selecting the desired input.
3.	INPUTS Sockets	5 BNC connectors that serve as the inputs to the machine.
4.	OUT Socket	1 BNC connector that serves as the output of the machine.
5.	EXT Socket	A single RCA socket that is used for switcher extension
6.	12VDC Socket	For connecting a DC power supply to the machine
7.	LINK Socket	A 9-pin D-sub female socket for parallel operation of several machines or for contact closure remote control.



5.4 Getting to Know Your VS-55YC Switcher

The Kramer **VS-55YC** is a high performance 5x1 vertical interval switcher designed for s-Video (Y/C) signals. One of up to five sources can be routed to one monitor, projector, or other receiving device. Since it switches during the vertical interval, transitions are glitch-free when sources share common reference sync. The LINK connector is designed to allow the use of a **VS-55A** to form “audio-follow-video” systems.

The **VS-55YC** also provides an EXT connector, which allows several units to be combined to form larger switching systems. For example, two units will form a 10x1, three will form a 15x1, etc. A 12VDC-power supply is included for typical operation but the optional model **VA-50P** can power up to six Kramer devices requiring 12VDC. All Kramer **VM-50** and **VS-55** series products can be rack-mounted using the model **RK-50R** kit that holds two units in one or two vertical rack spaces. Panel features of the **VS-55YC** are described in Figure 4 and Table 4.

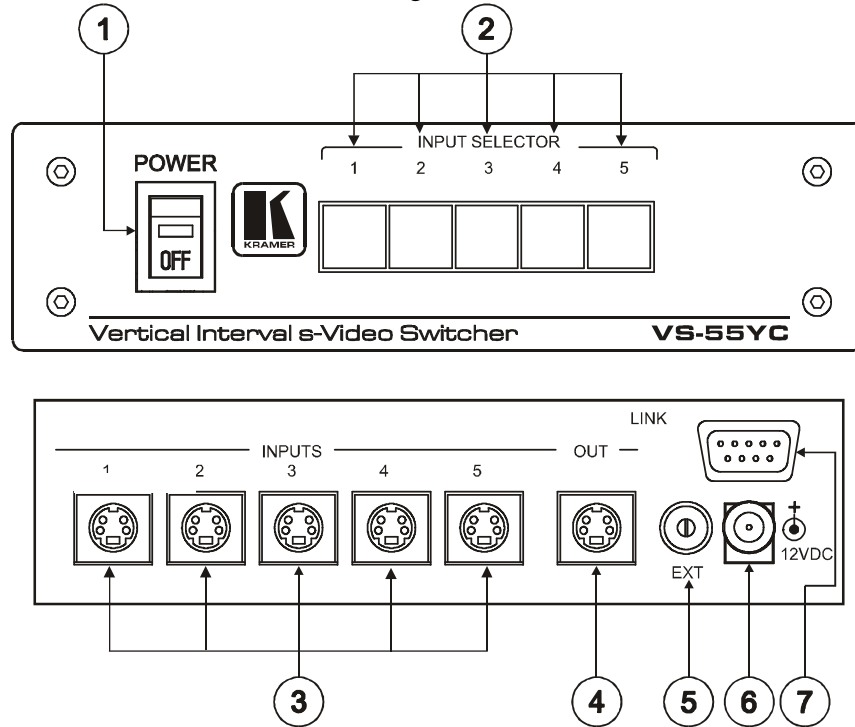

Figure 4: VS-55YC Front and Rear Panel Features

Table 4: VS-55YC Front and Rear Panel Features

No.	Feature	Function
1.	POWER Switch	Supplies power to the machine
2.	INPUT Selector Switches	Illuminated touch-button switches for selecting the desired input.
3.	INPUTS Sockets	5 4P connectors that serve as the inputs to the machine.
4.	OUT Socket	1 4P connector that serves as the output of the machine.
5.	EXT Socket	A single RCA socket that is used for switcher extension
6.	12VDC Socket	For connecting a DC power supply to the machine
7.	LINK Socket	A 9-pin D-sub female socket for parallel operation of several machines or for contact closure remote control.



6 INSTALLATION

6.1 Rack Mounting

The Kramer **VS-55** series switchers may be rack-mounted in a standard 19" (1 or 2U) EIA rack assembly, using a special Adapter (**RK-50R** - 1U or a 2U model) and a mounting bracket (see section 4.1). They can also be table mounted using their rubber feet or the provided mounting brackets. These devices do not require any specific spacing above or below the unit for ventilation. To rack mount any of the machines, follow the installation instructions enclosed with the adaptor.

7 CONNECTING TO VIDEO OR AUDIO DEVICES

Video sources and output devices (such as monitors or recorders) may be connected to the switchers through the BNC connectors (**VS-55V**), through the RCA connectors (**VS-55**, **VS-55A**), or through the 4P connectors (**VS-55YC**) located on the back of the unit. The active inputs should be terminated by the connecting source. The output signal format should match that of the input signal format, (e.g.: if Composite video is input, then Composite video is output.) The signals supported by the various models are video, s-video, RGB/YUV and audio signals.

8 USING THE SWITCHERS

8.1 Connecting and Controlling the Switchers

1. Connect all inputs of the "**VS-55**" family switcher to the sources to be switched, taking care to use the right high quality cables. If linking is needed, interconnect the "linked" units with a DB9 male-to-male flat cable. Use video cables for video, audio cables for audio, etc. Use of the wrong cable will impair output quality.
2. Connect the output of the "**VS-55**" type switcher to the input(s) of the acceptor, again using high quality cables, turn on all units - sources, acceptors and the "**VS-55**" units, and you are ready to go.
3. If there no video signal is connected to input #1, then the **VS-55V** and **VS-55YC** units operate as electronic switchers without Vertical Interval switching.
4. If you would like to extend the number of switched inputs, say forming a 10x1 switcher, it can only be done by using two machines of the same type, e.g., two **VS-55Vs** or two **VS-55YCs**, etc. In order to do so, you should connect both EXT connectors to each other using a screened cable (an audio cable will do the job well). Then connect outputs of both machines to each other using a "T" connector. The combined output should then be connected to your acceptor. The concept of operation is as following: the machines "sense" each other's status via the EXT connector, and when a certain machine "senses" that the other is active, it shuts off it's own output circuitry, so in every given instance, only one machine is actively connected to the acceptor.
5. The cables leading from the combined output to the acceptor's input and between the outputs of the "**VS-55**" linked machines should be as short as possible.
6. Connect the "**VS-55**" machines to an appropriate 12 V DC source, observing correct polarity (center pin is positive).
7. Turn on the sources, The "**VS-55**" switcher(s) and the acceptors.
8. If you have connected two or more machines via the EXT connector, when turning on the system, sometimes a random combination of switches may light. Press any of the switches on any of the interconnected "**VS-55**" units and the system will reset.
9. The **VS-55** family allows remote controlling the switcher(s) using the LINK connector. Connect a DB9 male plug with 9 wires leading from it to the remote location. A momentary touch of one of the relevant pins (see table 1) to the common VCC pin (pin no. 8) forces the switcher to activate the corresponding connection.

8.2 Extending a Switcher

Figure 5 illustrates typical switching extension setup using two VS-55V switchers to create a 10x1 switcher.

- First, connect a dual or shielded cable between the RCA EXT connectors of the machines. An audio cable with two RCA connectors at the ends will do, if the distance between the switchers is no more than 5 meters.
- Connect a “T” connector to the output of switcher 1.
- Connect a high quality coax BNC to BNC cable between one of the edges of the “T” connector and the output socket of switcher 2.
- Connect a high quality coax BNC to BNC cable between the other edge of the “T” connector and the input of your acceptor.
- Connect 5 video sources (in this case using the VS-55V) to the input sockets of switcher 1.
- Connect another 5 video sources to the input sockets of switcher 2.
- Connect the power supply to the VS-55V machines.
- Operate the VS-55V machines, the video sources and the acceptor.
- The switches on the front of switcher 1 correspond to inputs 1-5, and on switcher 2 to inputs 6-10. When you press a button on switcher 1, for example, all the other buttons, including the ones on switcher 2 will be “off”.
- To add more switchers (forming a 15x1, 20x1 etc. configuration), interconnect all EXT sockets from all switchers using appropriate connectors, and “T” connect all outputs in a similar way: You should use a “T” connector for all video outputs but the last. From the first machine’s “T” connector, connect a BNC to BNC cable to the second machine’s “T” connector, from the second machine to the third and so on. The second free “T” output of machine 1 should be connected to your video acceptor.
- All interconnected machines should be close to each other, otherwise signal quality might be affected.

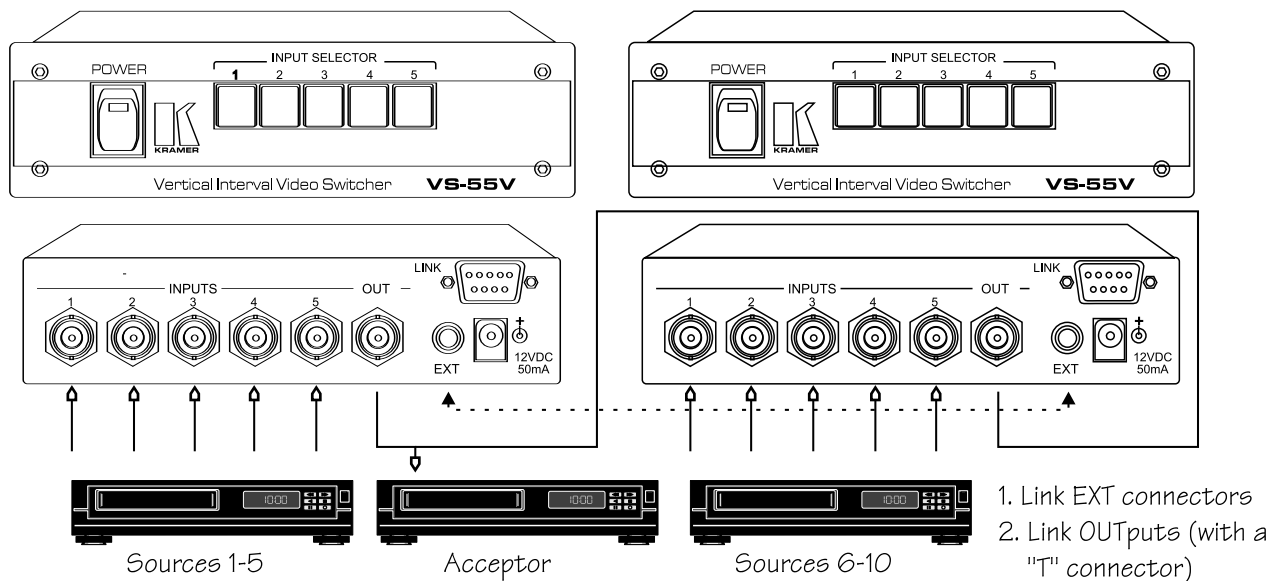

Figure 5: Extending a Switcher – Adding Inputs

8.3 Parallel Signal Switching

Figure 6 illustrates a typical setup for switching s-Video and Audio signals in parallel, thus forming an Audio follow video switcher. For parallel switching, as many switchers may be added as needed. For example, three VS-55V switchers may be operated in parallel, forming a YUV or and RGB 5x1 switching system.

- Connect a 9-pin D-sub to 9-pin D-sub flat cable between the “LINK” connectors of the switchers.
- Connect 5 s-Video sources to the input sockets of the VS-55YC switcher using high quality cables with 4P connectors at the ends.
- Connect 5 stereo audio sources to the input sockets of the VS-55A switcher, using high quality cables with RCA connectors at the ends.
- Connect the output of of the VS-55YC to the input of your s-Video acceptor.
- Connect the output of of the VS-55A to the input of your Audio acceptor.
- Connect the power supply to the VS-55YC and VS-55A.
- Operate the VS-55 machines, the sources and the acceptor.
- For example, pressing switch #2 of the Input Selector switch bank of the VS-55YC, will automatically activate switch #2 of the VS-55A.

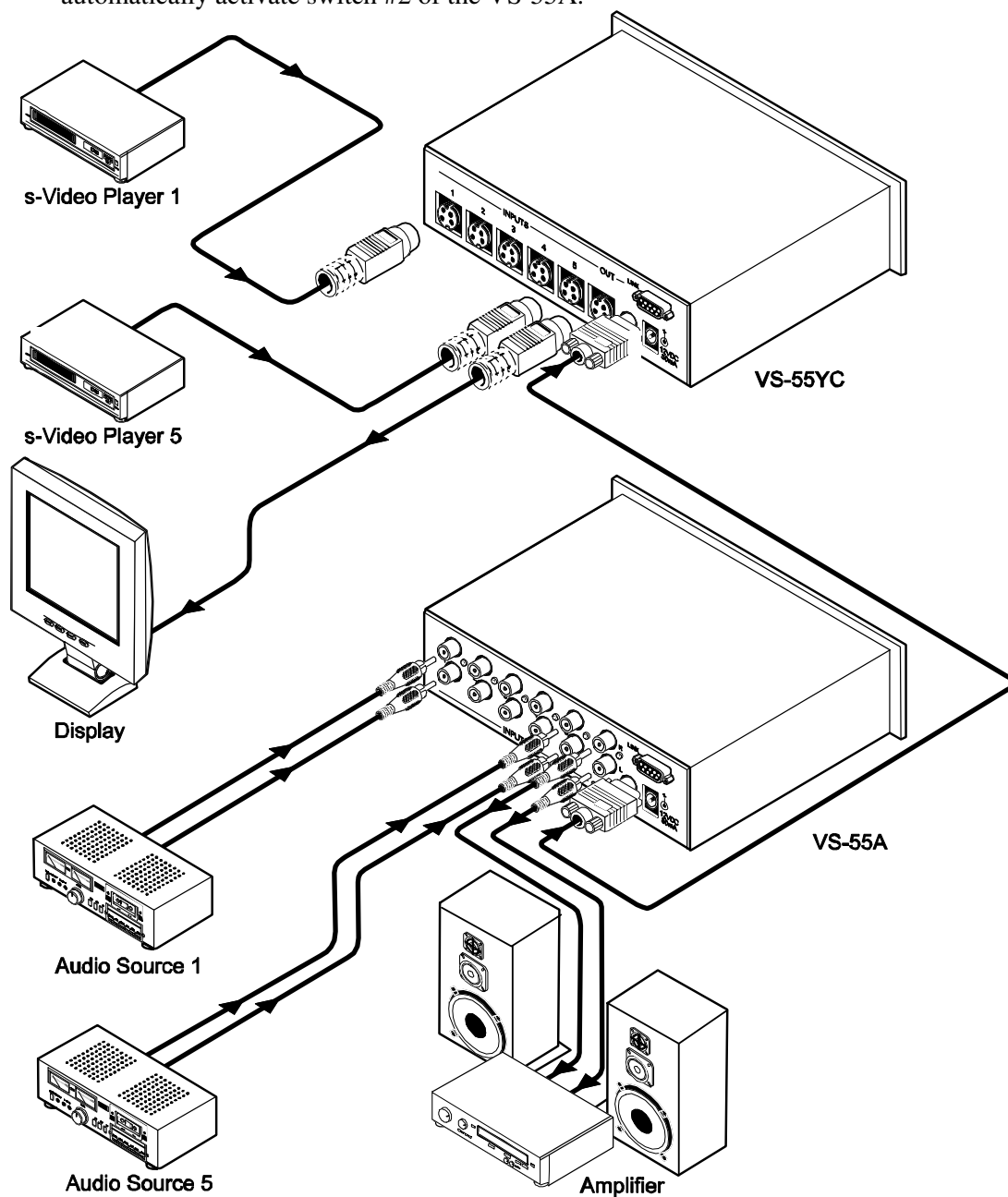

Figure 6: Parallel Signal Switching

8.4 Remote Controlling the Switchers

All the switchers of the VS-55 family may be contact-closure remote controlled via the “LINK” connector. The distance between the switcher and the remote contact-closure assembly should preferably no be more than 10 meters. Use table 5 below for identification of the 9-pin D-sub pin numbers and their use.

- Connect a 9-pin D-sub male plug and cable (screened or flat) into the LINK connector of the VS-55 family switcher.
- Identify the wires corresponding to the relevant pins in table 5.
- Pin #3 which is +8V (VCC) should be the common line of the contact closure assembly. Momentarily touching one of the wires connected to pins 5, 6, 7, 8, 9 of the 9-pin D-sub connector will activate the corresponding switch. For example – forming a momentary connection between pin #7 wire to the VCC wire (pin #3) will force the switcher to activate switch #4. Connecting pin #9 wire momentarily to pin #3 wire will activate switch #2.
- Be careful not to short pin #3 (VCC) and pin #2 (ground) as it may blow the fuse of the machine.
- Connecting several switchers and their LINK connectors in parallel will enable the user to activate all interconnected switchers with one momentary connection.

9-pin D-sub Pin Number	Connected to:
2	Ground
3	VCC = 8V
5	Switch # 1
6	Switch # 5
7	Switch # 4
8	Switch # 3
9	Switch # 2
1	Not Connected
4	Not Connected

Table 5: Pin Configuration of the “LINK” Connector

9 TAKING CARE OF YOUR MACHINE

Do not locate your machine in an environment where it is susceptible to dust or moisture. Both of these may damage the electronics, and cause erratic operation or failure.

Do not locate your machine where temperature and humidity may be excessive.

Do not clean your machine with abrasives or strong cleaners. Doing so may remove or damage the finish, or may allow moisture to build up.

Take care not to allow dust or particles to build up inside unused or open connectors.



10 TROUBLESHOOTING

10.1 Video Signal

Problem	Remedy
No video at the output device, regardless of input selected.	Confirm that your source and output devices are powered on and connected properly. The input of your machine should be of an identical signal format at the output of your source. Signals at the output of your machine should be of an identical signal format as at the input of your display. Confirm that any other device in the signal path have the proper input and/or output selected. Use the Video Tester to test the video path leading to/from your machine (see section 4.1 "Video Tester")
Video level is too high or too dim.	Verify that the lines are well matched through 75ohm impedance; otherwise it results in a video level that is too high or too dim. Confirm that the connecting cables are of high quality and properly inserted. Check level controls located on your source input device or output display.
Noise bars "roll" up or down in the output image or: Low Frequency Hum in the output signal	Hum bars (ground loop) are caused by a difference in the ground potential of any two or more devices connected to your signal path. WARNING! <i>Do not disconnect the ground from any piece of video equipment in your signal path!</i> Check the following to remove hum bars: Confirm that all interconnected equipment is connected to the same phase of power, if possible. Remove equipment connected to that phase that may introduce noise, such as motors, generators, etc. Disconnect all interconnect cables and reconnect them one at a time until ground loop reappears. Disconnect the affected cable and replace, or insert an isolation transformer in the signal path.

10.2 Audio Signal

Problem	Remedy
No audio at the output device, regardless of input selected	Confirm that your sources and output device are powered on and connected properly. Audio signals connected to the input of your machine should be properly wired to the output of your source. Audio signals connected to the output of your machine should be properly wired to the input of your machine or recorder. Confirm that any other amplifiers in the signal path have the proper input and/or output selected. Pay special attention to input amplifiers that may be built into your acceptor.
Audio level is too low	Confirm that the connecting cables are of high quality and properly built. Take special care in noting the wiring configuration of balanced to unbalanced cables. Check level controls located on your source input device or output display or recorder.



LIMITED WARRANTY

Kramer Electronics (hereafter *Kramer*) warrants this product free from defects in material and workmanship under the following terms.

HOW LONG IS THE WARRANTY

Labor and parts are warranted for seven years from the date of the first customer purchase.

WHO IS PROTECTED?

Only the first purchase customer may enforce this warranty.

WHAT IS COVERED AND WHAT IS NOT COVERED

Except as below, this warranty covers all defects in material or workmanship in this product. The following are not covered by the warranty:

1. Any product which is not distributed by Kramer, or which is not purchased from an authorized Kramer dealer. If you are uncertain as to whether a dealer is authorized, please contact Kramer at one of the agents listed in the Web site www.kramerelectronics.com.
2. Any product, on which the serial number has been defaced, modified or removed, or on which the WARRANTY VOID IF TAMPED sticker has been torn, reattached, removed or otherwise interfered with.
3. Damage, deterioration or malfunction resulting from:
 - i) Accident, misuse, abuse, neglect, fire, water, lightning or other acts of nature
 - ii) Product modification, or failure to follow instructions supplied with the product
 - iii) Repair or attempted repair by anyone not authorized by Kramer
 - iv) Any shipment of the product (claims must be presented to the carrier)
 - v) Removal or installation of the product
 - vi) Any other cause, which does not relate to a product defect
 - vii) Cartons, equipment enclosures, cables or accessories used in conjunction with the product

WHAT WE WILL PAY FOR AND WHAT WE WILL NOT PAY FOR

We will pay labor and material expenses for covered items. We will not pay for the following:

1. Removal or installations charges.
2. Costs of initial technical adjustments (set-up), including adjustment of user controls or programming. These costs are the responsibility of the Kramer dealer from whom the product was purchased.
3. Shipping charges.

HOW YOU CAN GET WARRANTY SERVICE

1. To obtain service on you product, you must take or ship it prepaid to any authorized Kramer service center.
2. Whenever warranty service is required, the original dated invoice (or a copy) must be presented as proof of warranty coverage, and should be included in any shipment of the product. Please also include in any mailing a contact name, company, address, and a description of the problem(s).
3. For the name of the nearest Kramer authorized service center, consult your authorized dealer.

LIMITATION OF IMPLIED WARRANTIES

All implied warranties, including warranties of merchantability and fitness for a particular purpose, are limited in duration to the length of this warranty.

EXCLUSION OF DAMAGES

The liability of Kramer for any effective products is limited to the repair or replacement of the product at our option. Kramer shall not be liable for:

1. Damage to other property caused by defects in this product, damages based upon inconvenience, loss of use of the product, loss of time, commercial loss; or:
2. Any other damages, whether incidental, consequential or otherwise. Some countries may not allow limitations on how long an implied warranty lasts and/or do not allow the exclusion or limitation of incidental or consequential damages, so the above limitations and exclusions may not apply to you.

This warranty gives you specific legal rights, and you may also have other rights, which vary from place to place.

NOTE: All products returned to Kramer for service must have prior approval. This may be obtained from your dealer.

This equipment has been tested to determine compliance with the requirements of:

- EN-50081: "Electromagnetic compatibility (EMC);
generic emission standard.
Part 1: Residential, commercial and light industry"
- EN-50082: "Electromagnetic compatibility (EMC) generic immunity standard.
Part 1: Residential, commercial and light industry environment".
- CFR-47: FCC Rules and Regulations:
Part 15: "Radio frequency devices
Subpart B Unintentional radiators"

CAUTION!

- ☒ Servicing the machines can only be done by an authorized Kramer technician. Any user who makes changes or modifications to the unit without the expressed approval of the manufacturer will void user authority to operate the equipment.
- ☒ Use the supplied DC power supply to feed power to the machine.
- ☒ Please use recommended interconnection cables to connect the machine to other components.



For the latest information on our products and a list of Kramer distributors, visit our Web site:
www.kramerelectronics.com,
where updates to this user manual may be found.
We welcome your questions, comments and feedback.

 <p>Caution</p>	<p>Safety Warning: Disconnect the unit from the power supply before opening/servicing.</p>
---	---



P/N: 2900-002040



Rev: 4