

INVOTONE

USER'S MANUAL

ACTIVE SPEAKER CABINET
IPS 10LA/12LA/15LA

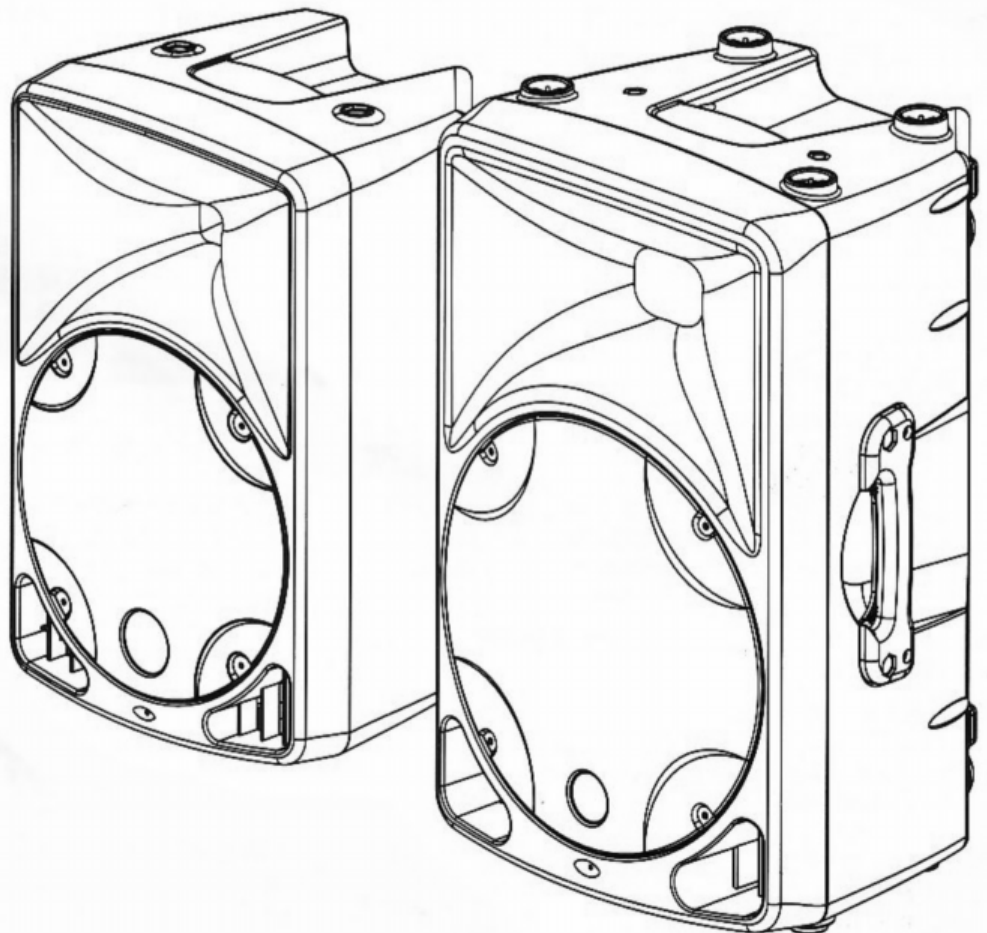

IMPORTANT SAFETY INSTRUCTION



TO REDUCE THE RISK OF ELECTRIC SHOCK PLEASE DO NOT REMOVE THE COVER OR THE BACK PANEL OF THIS EQUIPMENT. THERE ARE NO PARTS NEEDED BY USER INSIDE THE EQUIPMENT. FOR SERVICE, PLEASE CONTACT QUALIFIED SERVICE CENTERS.

 This symbol, wherever used, alerts you to the presence of un-insulated and dangerous voltages within the product enclosure. These are voltages that may be sufficient to constitute the risk of electric shock or death.

 This symbol, wherever used, alerts you to important operating and maintenance instructions. Please read.

- ⊕ Protective Ground Terminal
- ~ AC mains (Alternating Current)
- ⚡ Hazardous Live Terminal

ON: Denotes the product is turned on.

OFF: Denotes the product is turned off.

CAUTION

Describes precautions that should be observed to prevent damage to the product.

1. Read this Manual carefully before operation.
2. Keep this Manual in a safe place.
3. Be aware of all warnings reported with this symbol.
4. Keep this Equipment away from water and moisture.
5. Clean it only with dry cloth. Do not use solvent or other chemicals.
6. Do not damp or cover any cooling opening. Install the equipment only in accordance with the Manufacturer's instructions.
7. Power Cords are designed for your safety. Do not remove Ground connections! If the plug does not fit your AC outlet, seek advice from a qualified electrician. Protect the power cord and plug from any physical stress to avoid risk of electric shock. Do not place heavy objects on the power cord. This could cause electric shock or fire.
8. Unplug this equipment when unused for long periods of time or during a storm.
9. Refer all service to qualified service personnel only. Do not perform any servicing other than those instructions contained within the User's Manual.
10. To prevent fire and damage to the product, use only the recommended fuse type as indicated in this manual. Do not short-circuit the fuse holder. Before replacing the fuse, make sure that the product is OFF and disconnected from the AC outlet.

WARNING

To reduce the risk of electric shock and fire, do not expose this equipment to moisture or rain.



Dispose of this product should not be placed in municipal waste and should be separate collection.

11. Move this Equipment only with a cart, stand, tripod, or bracket, specified by the manufacturer, or sold with the Equipment. When a cart is used, use caution when moving the cart / equipment combination to avoid possible injury from tip-over.



12. Permanent hearing loss may be caused by exposure to extremely high noise levels. The US. Government's Occupational Safety and Health Administration (OSHA) has specified the permissible exposure to noise level. These are shown in the following chart:

HOURS X DAY	SPL	EXAMPLE
8	90	Small gig
6	92	train
4	95	Subway train
3	97	High level desktop monitors
2	100	Classic music concert
1,5	102	
1	105	
0,5	110	
0,25 or less	115	Rock concert

According to OSHA, an exposure to high SPL in excess of these limits may result in the loss of heat. To avoid the potential damage of heat, it is recommended that Personnel exposed to equipment capable of generating high SPL use hearing protection while such equipment is under operation.

The apparatus shall be connected to a mains socket outlet with a protective earthing connection.

The mains plug or an appliance coupler is used as the disconnect device, the disconnect device shall remain readily operable.

INDEX

INTRODUCTION	3
HOOKUP DIAGRAMS	4
QUICK START	5
RIGGING	6
PANEL DESCRIPTION	7
FREQUENCY RESPONSE DIAGRAM	8
WIRE CONNECTIONS	9
TECHNICAL SPECIFICATIONS	10

INTRODUCTION

Thank you for choosing **INVOTONE**. The **INVOTONE IPS Series** cabinets have been designed to provide a cost effective high grade solution while maintaining high quality cabinet construction and optimum components. The **IPS Series**, can be used for all types of applications including, but not limited to, churches, conference centers and discos. The woofer and neodymium driver combination provides excellent performance rivaling those cabinets costing much more.

Our Professional Audio Products are designed and tested by a highly qualified engineering team with more than 20 years of experience. Great care is placed in delivering products with excellent performance, specifications and dependable reliability. Also great emphasis is placed in creating and bringing to market products that can fill multiple applications and also offer customers exceptional value.

INSTALLATION TIPS

- Speakers should be placed in a position that allows for unobstructed sound projection. In many instances it is beneficial for speakers to elevate on tripod stands to achieve maximum dispersion and reach. Consider **INVOTONE** speaker stand or equivalent to raise speakers.
- Using quality cables ensure best possible sound. Consider using **INVOTONE** 16 or 14 gauge cables or equivalent.
- For best results match the speakers to a good amplifier that matches the wattage and impedance of your speakers. Proper amplification power results in good quality audio and longer component life. Check out.
- Avoid pointing microphone directly at an amplified speaker otherwise could cause feedback possible damaging speaker components and your hearing.

Enjoy the sound!

QUICK START

Make all initial connections with all the equipments powered off, and ensure that all the main volume controls are turned completely down.

- 1). Connect one side of the signal cable at your audio mixer into output left / right (with Stereo-Jack or XLR) and the other side of the cable into the line input Stereo-Jack) of your active speaker cabinet.
- 2). Connect the power cord to mains.
- 3). Turn on your mixer first, then the active speaker cabinets.
- 4). Turn up the volume control of the active speaker cabinets.
- 5). Use PFL function to get the proper input level for the mixer, and adjust the main mix level control to manipulate the output level.
- 6). After using, turn off your active speaker cabinets first, then the mixer.

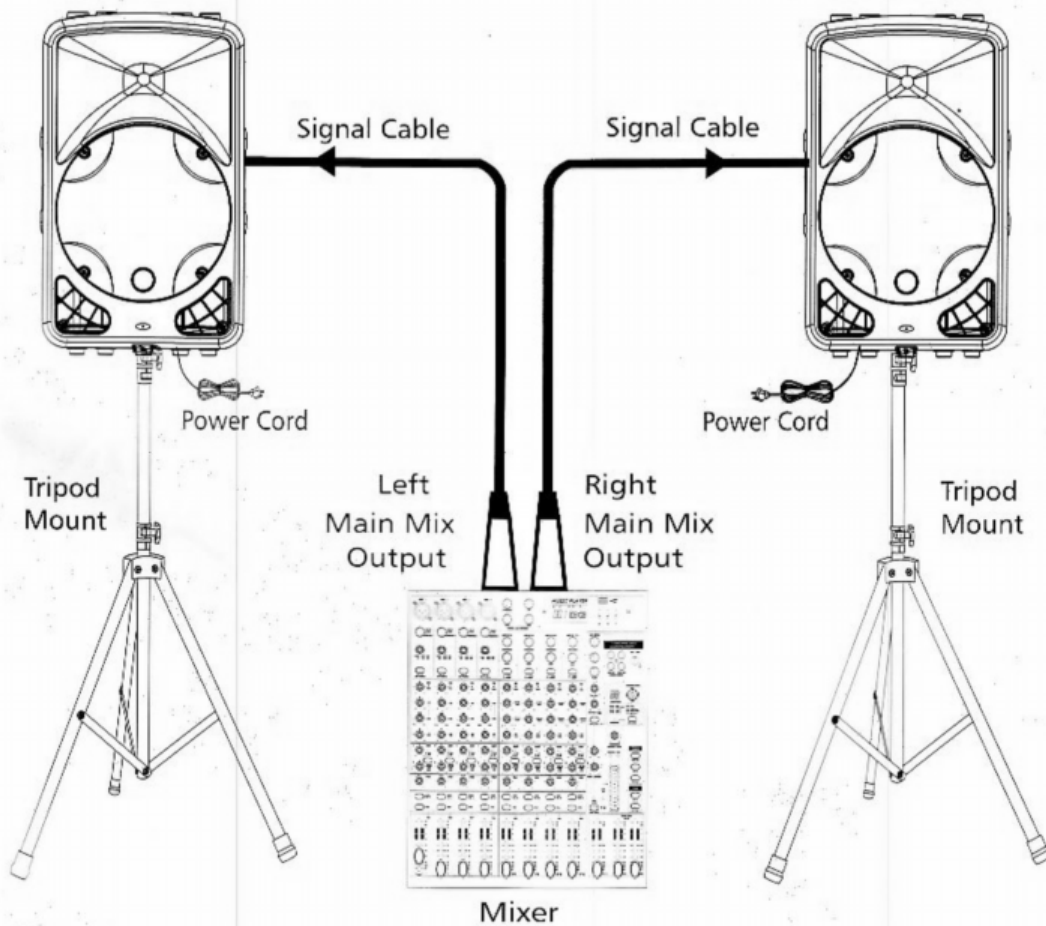

HOOKUP DIAGRAMS

Two speaker in stereo operation

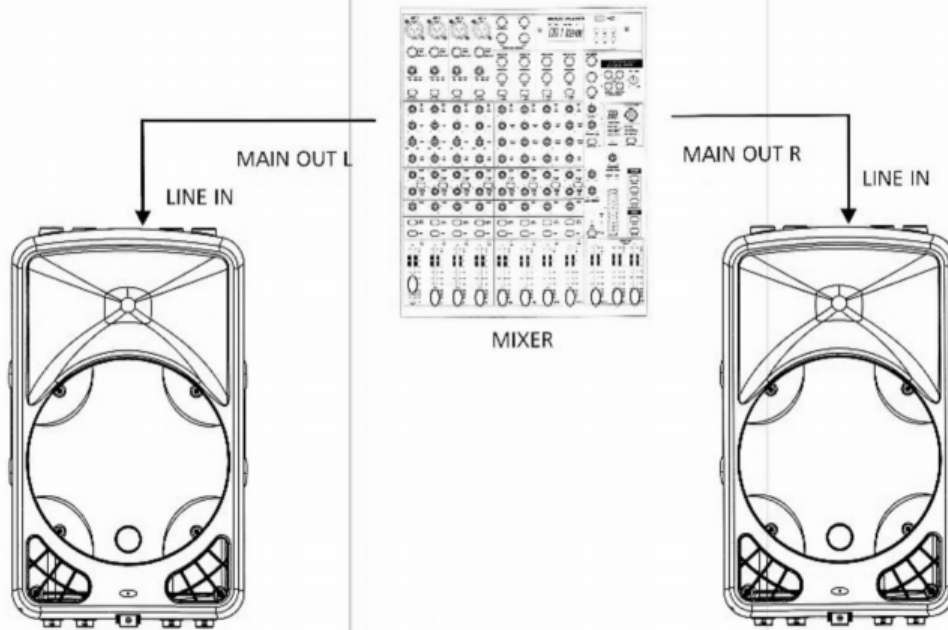

Multiple speakers with the same stereo source

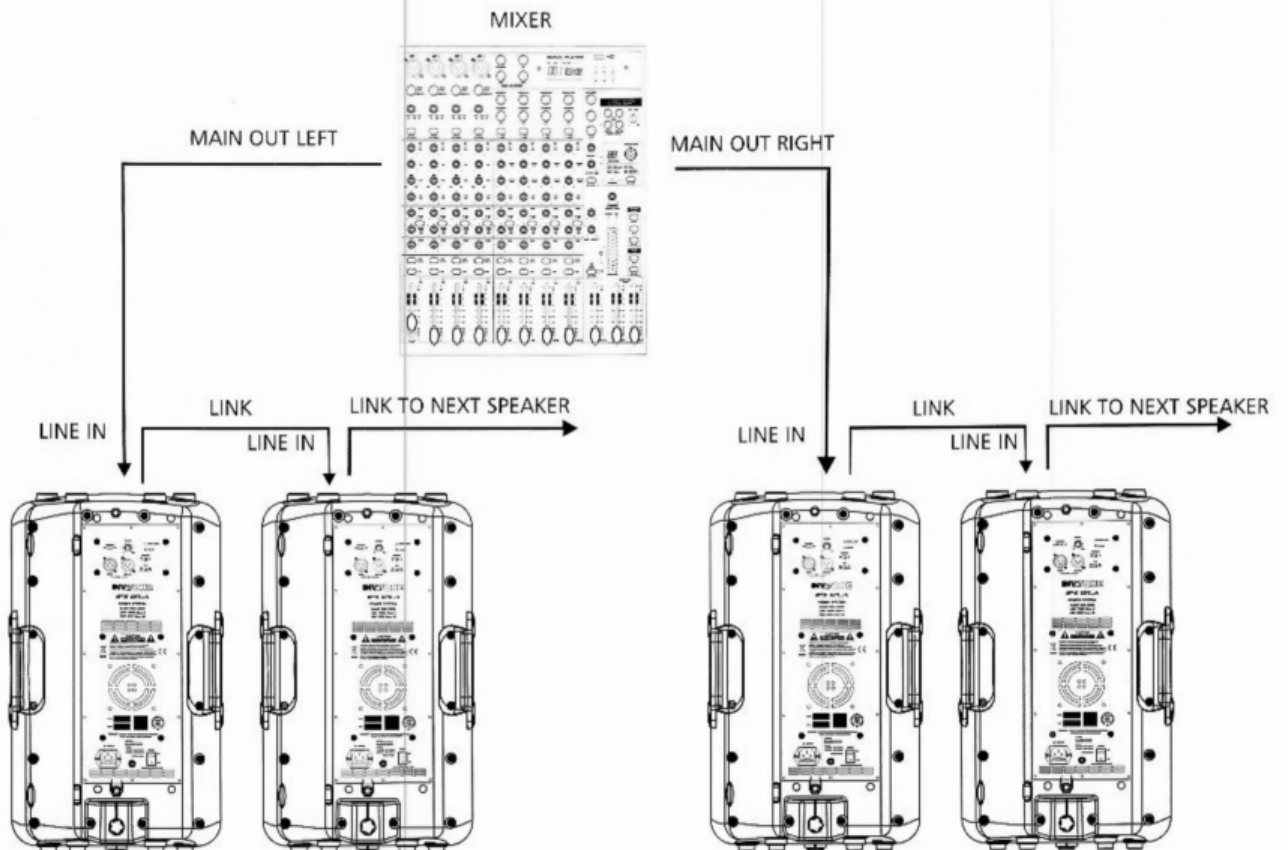

PANEL DESCRIPTION

AMP INTERFACE

- (1) BI-POLAR MAIN POWER SWITCH
 - (2) AC POWER SOCKET WITH MAIN FUSE
 - (3) LINE/MIC INPUT ON COMBO CONNECTOR (IPS 8A /10A ONLY LNE IN)
 - (4) MIX OUT ON XLR CONNECTOR (IPS 8A /10A ONLY LINK)
 - (5) "INPUT SENSITIVITY" SWITCH FOR LINE & MIC
 - (6) MAIN VOLUME CONTROL
 - (7) CLIP INDICATOR RED LED
 - (8) POWER INDICATOR GREEN LED
 - (9) CONTOUR ON/OFF
 - (10) GROUND SWITCH
- CONTOUR ON preset is to equalize the mix for optimal music play back

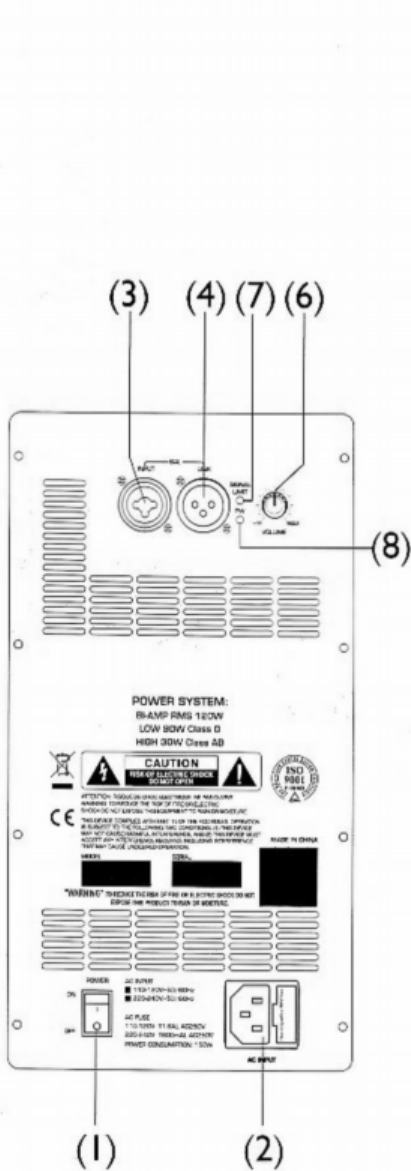

IPS 10LA

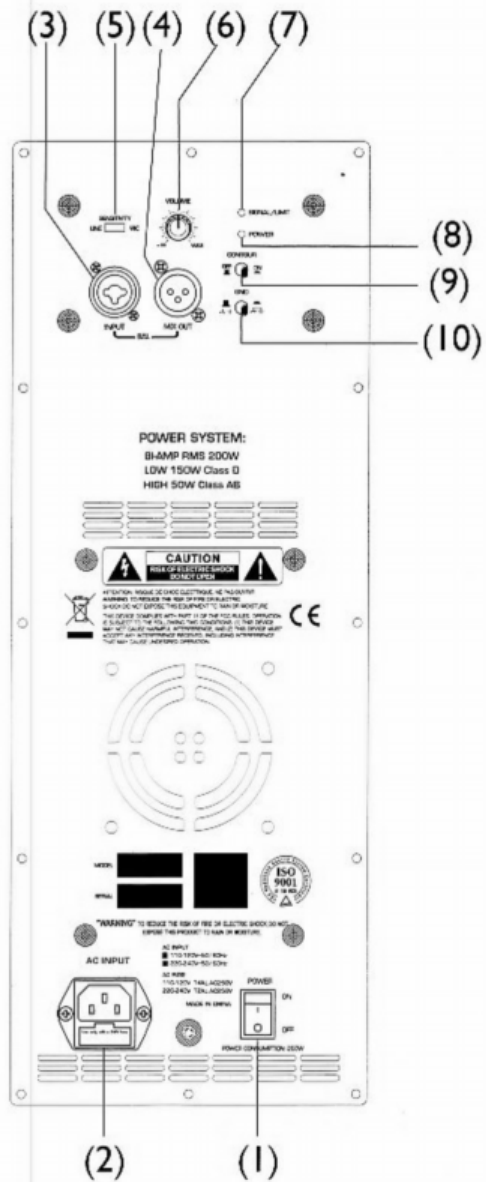

IPS 12LA / 15LA

RIGGING

The IPS series speaker cabinet also provides the suspension points for installation.
(M10×1.5PH LENGTH: 30mm).

For further details, please refer to the below illustration(OPTIONAL FUNCTIONAL)

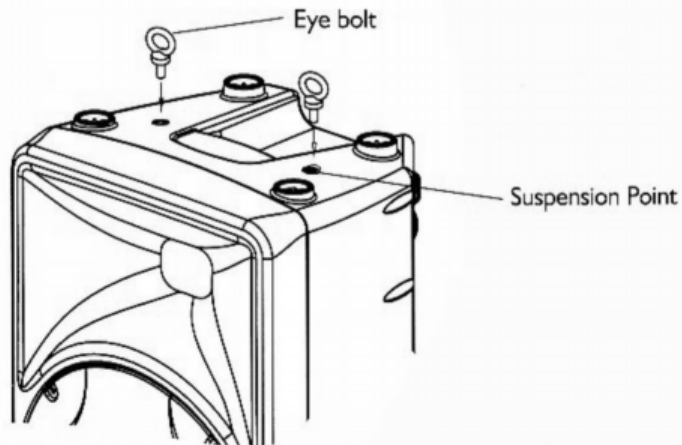

The floor use is as a function of a monitor when the angle is 45°

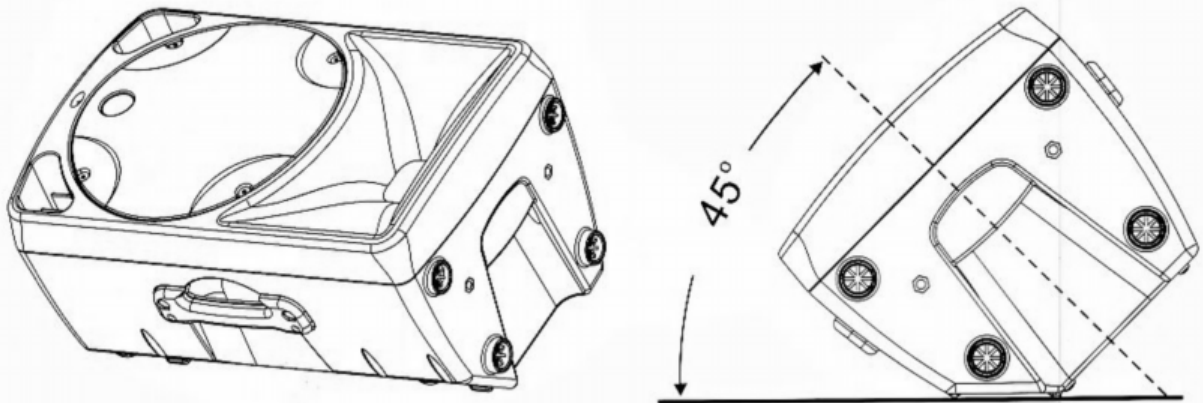

FREQUENCY RESPONSE DIAGRAM

IPS 10LA

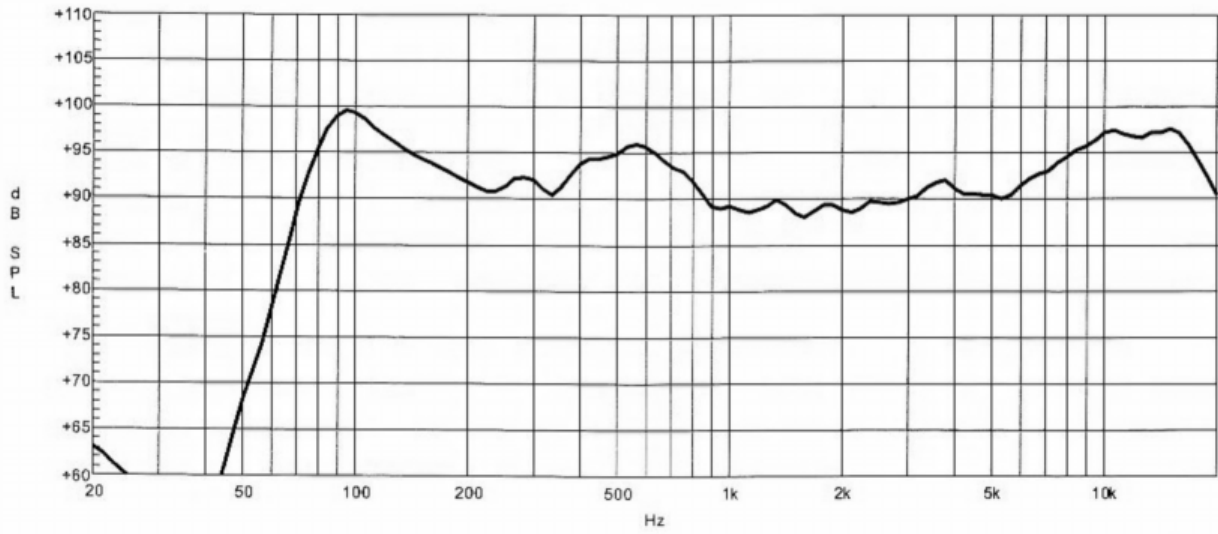

IPS 12LA

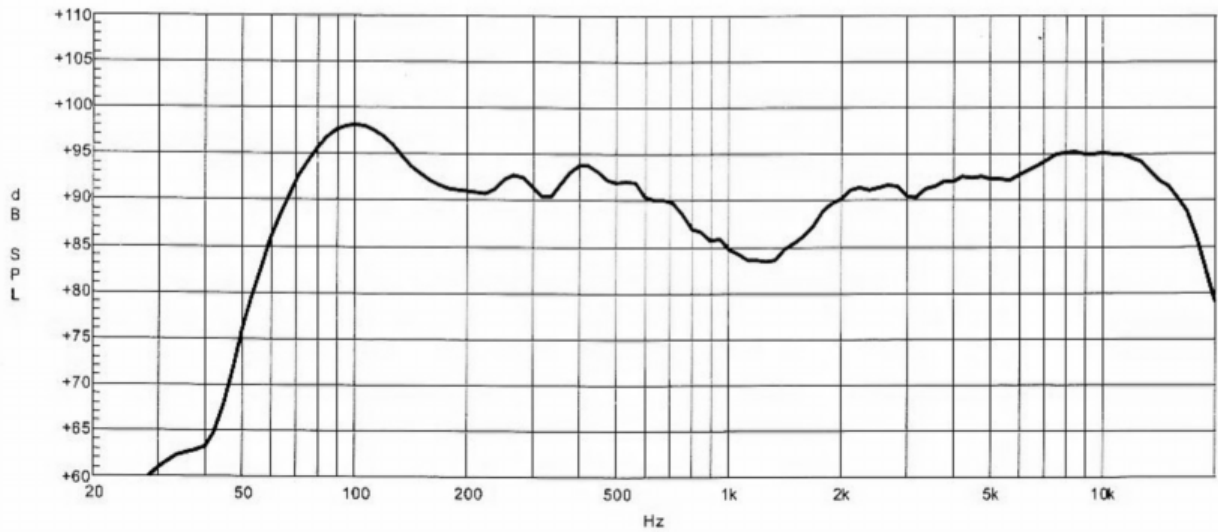

IPS 15LA

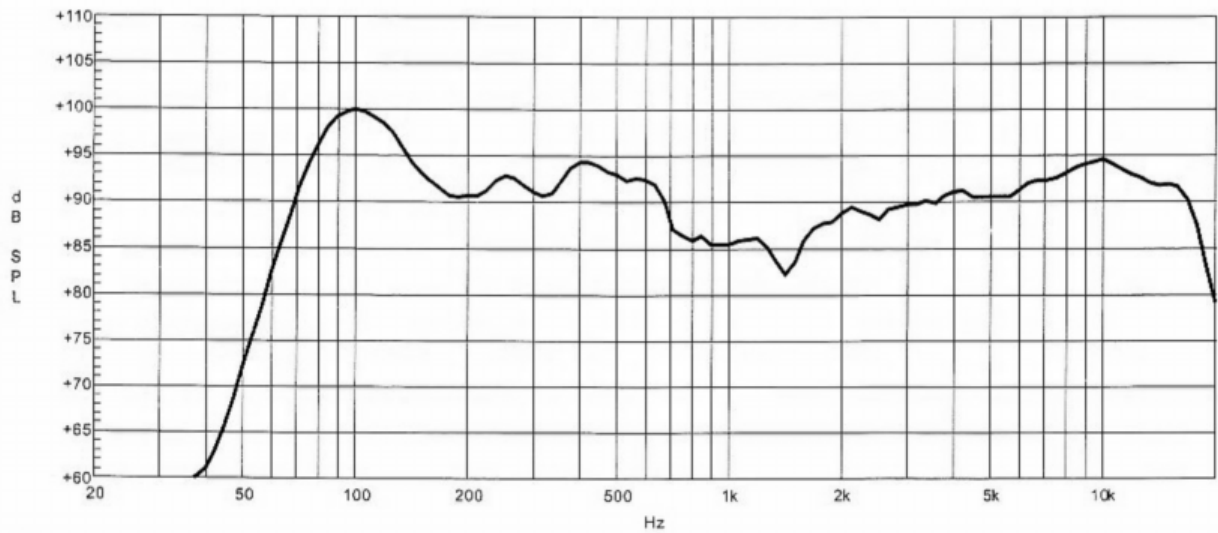

WIRE CONNECTIONS

Both connectors, 1/4" XLR or TRS, can be wired in balanced or unbalanced way, depending on the work necessity. The following ones are examples of how these connectors can be wired:

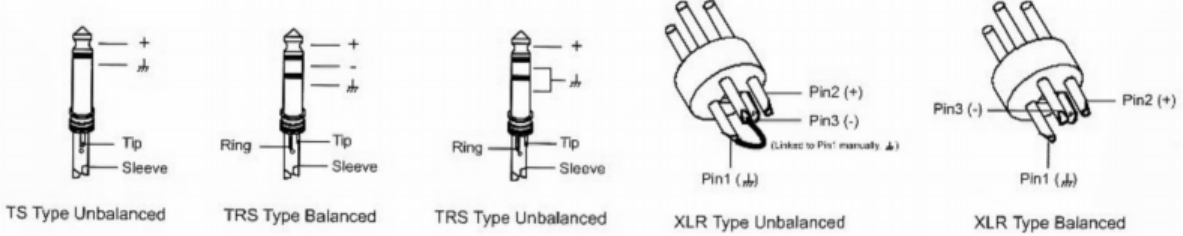

For Active Speaker Cabinets

As to these circumstances, audio connections is mostly intended for the signal flow, so, determine the wire configuration according to your real application system and its connecting facility. Normally, you have the following choices:

• Balanced

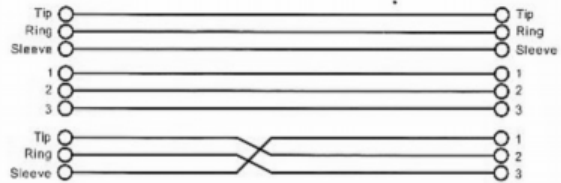
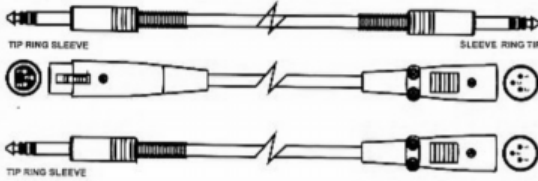

• Unbalanced

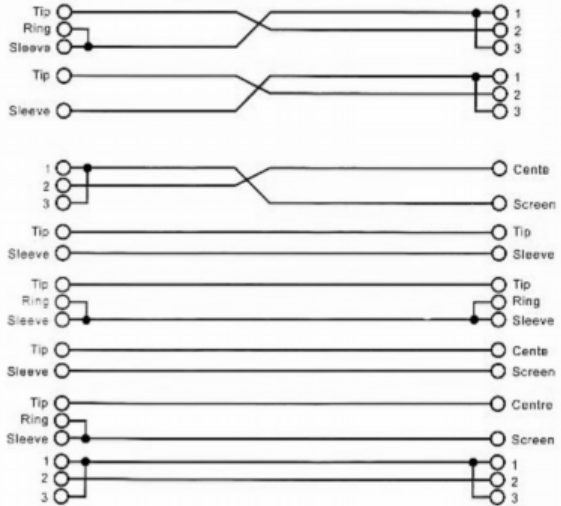
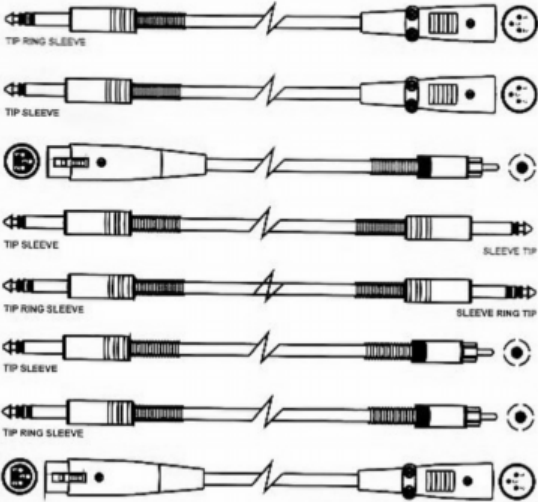

TECHNICAL SPECIFICATIONS

Model Active	IPS 10LA
System Type	2-Way Active Vented Speaker
Transducer Low	10" Woofer, 1.5"voice coil
Transducer High	1" Ferrite Driver, 1" Voice Coil
Horn Coverage H°XV°	90°H x 45°V
Frequency Response	65Hz-20KHz (-6dB)
Crossover Frequency	2800Hz
Max SPL(1M)	116dB Max.
Power system	Class D SMPS (Bi-AMP , LF 90W/RMS + HF 30W/RMS), 480W Peak
Connector	Line In&Link With XLR
External Controls	Volume Control/Power ON with Green LED//Clip Limiter with Red LED
Electronic Protections	Thermal/Overload/Analog limiter/Compressor
Power Supply	100V-240V ~50/60Hz
Enclosure Construction	Plastic cabinet,Trapezoidal & Monitor shape,Metal grille,1*Handle-On Top
Mounting	36mm standard pole-mount
Dimensions (HxWxD)	460*285*265mm
Net Weight	6.92 (kg)/15.26lbs

TECHNICAL SPECIFICATIONS

Model Active	IPS 12LA
System Type	2-Way Active Vented Speaker
Transducer Low	12" Woofer, 2" Voice Coil
Transducer High	1" Neodymium Driver, 1" Voice Coil
Horn Coverage H°XV°	90°H x 45°V
Frequency Response	55Hz-20KHz (-6dB)
Crossover Frequency	3500Hz
Max SPL(1M)	119dB Max.
Power system	200W Continuous Bi-Amp Analog Processor(Low: 150W / High:50W),PEAK 800W
Connector	Line/Mic Input with Combo &Link with XLR
External Controls	Volume Control/Line&Mic Switch/Contour on/Power on with Green LED/ Clip Limiter with Red LED/Ground Lift.
Electronic Protections	Thermal/Overload/Analog Limiter/Compressor
Power Supply	110-120V~50/60Hz or 220-240V~50/60Hz Switchable
Enclosure Construction	Plastic Cabinet, Trapezoidal & Monitor Shape, Metal Grille, Rubber feet,3* Handles (Top and both sides)
Mounting	36mm standard pole-mount
Dimensions (HxWxD)	607*380*337mm
Net Weight	13.75kg/30.31 lbs

Model Active	IPS 15LA
System Type	2-Way Active Vented Speaker
Transducer Low	15" Woofer, 2" Voice Coil
Transducer High	1" Neodymium Driver, 1" Voice Coil
Horn Coverage H°XV°	90°H x 45°V
Frequency Response	50Hz-20KHz(-6dB)
Crossover Frequency	3500Hz
Max SPL(1M)	121dB Max.
Power system	200W Continuous,Bi-Amp Analog Processor(Low: 150W / High:50W), PEAK 800W
Connector	Line/Mic Input With Combo &Link With XLR
Enclosure Controls	Volume Control/Line&Mic Switch/Contour on/Power on with Green LED/ Clip Limiter with Red LED/Ground Lift.
Electronic Protections	Thermal/Overload/Analog Limiter/Compressor
Power Supply	110-120V~50/60Hz or 220-240V~50/60Hz Switchable
Enclosure Construction	Plastic Cabinet, Trapezoidal & Monitor Shape, Metal Grille, Rubber feet,3* Handles (Top and both sides)
Mounting	36mm standard pole-mount
Dimensions (HxWxD)	625*386*366mm
Net Weight	14.86kg/32.80 lbs