

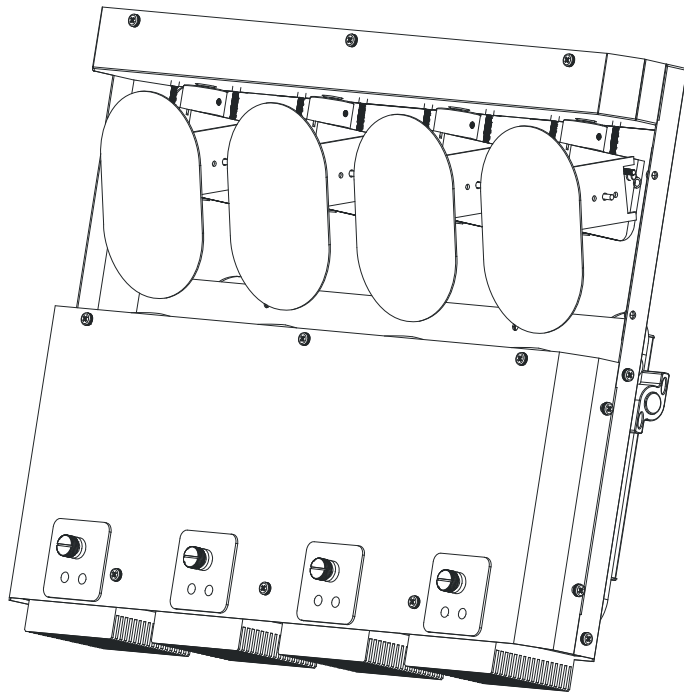

# QUAD SCAN PRO



## User Instructions

©2013 ADJ Products, LLC all rights reserved. Information, specifications, diagrams, images, and instructions herein are subject to change without notice. ADJ Products, LLC logo and identifying product names and numbers herein are trademarks of ADJ Products, LLC. Copyright protection claimed includes all forms and matters of copyrightable materials and information now allowed by statutory or judicial law or hereinafter granted. Product names used in this document may be trademarks or registered trademarks of their respective companies and are hereby acknowledged. All non-ADJ Products, LLC brands and product names are trademarks or registered trademarks of their respective companies.

**ADJ Products, LLC** and all affiliated companies hereby disclaim any and all liabilities for property, equipment, building, and electrical damages, injuries to any persons, and direct or indirect economic loss associated with the use or reliance of any information contained within this document, and/or as a result of the improper, unsafe, insufficient and negligent assembly, installation, rigging, and operation of this product.

## Quad Scan Pro

## General Information

**Unpacking:** Thank you for purchasing the Quad Scan Pro by ADJ Products, LLC®. Every Quad Scan Pro has been thoroughly tested and has been shipped in perfect operating condition. Carefully check the shipping carton for damage that may have occurred during shipping. If the carton appears to be damaged, carefully inspect your fixture for any damage and be sure all equipment necessary to operate the unit has arrived intact. In the event damage has been found or parts are missing, please contact our toll free customer support number for further instructions. Please do not return this unit to your dealer without contacting customer support first.

**Introduction:** The Quad Scan Pro is a DMX intelligent, RGBW “Quad Color” LED scanner. The Quad Scan Pro can operate as a stand alone fixture or in a Master/Slave configuration. The Quad Scan Pro has three operating modes; sound active mode, show mode, and DMX control. This fixture is suitable for theaters, studios, retail stores, and other similar locations. *For best results use fog or special effects smoke to enhance the beams projections.*

**Customer Support:** ADJ Products, LLC provides a toll free customer support line, to provide help and to answer any question should you encounter problems during your set up or initial operation. You may also visit us on the web at [www.adj.com](http://www.adj.com) for any comments or suggestions. Service Hours are Monday through Friday 8:00 a.m. to 4:30 p.m. Pacific Standard Time.

Voice: (800) 322-6337  
Fax: (323) 582-2941  
E-mail: [support@americandj.com](mailto:support@americandj.com)

**Warning!** To prevent or reduce the risk of electrical shock or fire, do not expose this unit to rain or moisture.

**Warning!** *This may cause severe eye damage. Avoid looking directly into the light source at all times!*

## Quad Scan Pro

## General Instructions

To optimize the performance of this product, please read these operating instructions carefully to familiarize yourself with the basic operations of this unit. These instructions contain important safety information regarding the use and maintenance of this unit. Please keep this manual with the unit, for future reference.

## Quad Scan Pro

## Features

- DMX-512 Protocol Compatible (1, 5, or 32 DMX Channels)
- X/Y Mirror Control
- 3 Operating Modes - Sound Active, Show Mode, and DMX Control
- Internal Microphone
- Digital Display for Address and Function Setting
- UC3 Controller (Not Included)
- Power Cord Daisy Chaining (See page 22)

## Quad Scan Pro

## Warranty Registration

The Quad Scan Pro carries a 3 year (1095 days) limited warranty. Please fill out the enclosed warranty card to validate your purchase and warranty. You may also register your product online at [www.americandj.com](http://www.americandj.com). All returned service items whether under warranty or not, must be freight pre-paid and accompany a return authorization (R.A.) number. If the unit is under warranty you must provide a copy of your proof of purchase invoice. Please contact ADJ customer support for a R.A. number.

## Quad Scan Pro

## Handling Precautions

**Caution!** There are no user serviceable parts inside this unit. Do not attempt any repairs yourself, doing so will void your manufactures warranty. In the unlikely event your unit may require service please contact ADJ.

*ADJ Products, LLC will not accept any liability for any resulting damages caused by the non-observance of this manual or any unauthorized modification to this unit.*

***For Your Own Personal Safety, Please Read and Understand This Manual Completely Before You Attempt To Install Or Operate This Unit!***

- To reduce the risk of electrical shock or fire, do not expose this unit rain or moisture
- Do not spill water or other liquids into or on to your unit.
- Do not attempt to operate this unit if the power cord has been frayed or broken.
- Do not attempt to remove or break off the ground prong from the electrical cord. This prong is used to reduce the risk of electrical shock and fire in case of an internal short.
- Disconnect from main power before making any type of connection.
- Do not remove the cover under any conditions. There are no user serviceable parts inside.
- Never operate this unit when it's cover is removed.
- Always be sure to mount this unit in an area that will allow proper ventilation. Allow about 6" (15cm) between this device and a wall.
- Do not attempt to operate this unit, if it becomes damaged.
- This unit is intended for indoor use only, use of this product outdoors voids all warranties.
- Always mount this unit in safe and stable matter.
- Power-supply cords should be routed so that they are not likely to be walked on or pinched by items placed upon or against them, paying particular attention to cords at plugs, convenience receptacles, and the point where they exit from the appliance.
- Cleaning -The fixture should be cleaned only as recommended by the manufacturer. See page 23 for cleaning details.
- Heat -This fixture should be situated away from heat sources such as radiators, heat registers, stoves, or other appliances (including amplifiers) that produce heat.
- The fixture should be serviced by qualified service personnel when:
  - A. Objects have fallen, or liquid has been spilled into the appliance.
  - B. The appliance has been exposed to rain or water.
  - C. The appliance does not appear to operate normally or exhibits a marked change in performance.

Fixture installation must always be secured with a secondary safety attachment, such as an appropriate safety cable.

Regardless of the rigging option you choose for your Quad Scan Pro always be sure to secure your fixture with a safety cable (not included). Attach a safety cable to the provided safety bolt.

**Caution:** For added protection mount the fixtures in areas outside of walking paths, seating areas, or areas where the fixture might be reached by unauthorized personal.

Before mounting the fixture to any surface, make sure that the installation area can hold a minimum point load of 10 times the device's weight.

To avoid injury, never stand directly below the device when mounting, removing, or servicing the fixture.

Always use and install a safety cable ( not included) as a safety measure to prevent accidental damage and/or injury in the event the clamp fails.

Be sure to complete all rigging and installation procedures before connecting the main power cord to the appropriate wall outlet.

**Power Supply:** The ADJ Quad Scan Pro contains a automatic voltage switch, which will auto sense the voltage when it is plugged into the power source. With this switch there is no need to worry about the correct power voltage, this unit can be plugged in anywhere.

**DMX-512:** DMX is short for Digital Multiplex. This is a universal protocol used by most lighting and controller manufactures as a form of communication between intelligent fixtures and controllers. A DMX controller sends DMX data instructions from the controller to the fixture. DMX data is sent as serial data that travels from fixture to fixture via the DATA “IN” and DATA “OUT” XLR terminals located on all DMX fixtures (most controllers only have a DATA “OUT” terminal).

**DMX Linking:** DMX is a language allowing all makes and models of different manufactures to be linked together and operate from a single controller, as long as all fixtures and the controller are DMX compliant. To ensure proper DMX data transmission, when using several DMX fixtures try to use the shortest cable path possible. The order in which fixtures are connected in a DMX line does not influence the DMX addressing. For example; a fixture assigned a DMX address of 1 may be placed anywhere in a DMX line, at the beginning, at the end, or anywhere in the middle. Therefore, the first fixture controlled by the controller could be the last fixture in the chain. When a fixture is assigned a DMX address of 1, the DMX controller knows to send DATA assigned to address 1 to that unit, no matter where it is located in the DMX chain.

**Data Cable (DMX Cable) Requirements (For DMX and Master/Slave Operation):** The Quad Scan Pro can be controlled via DMX-512 protocol. The Quad Scan Pro can be a 1, 5, or 32 channel DMX unit. The DMX address is set electronically using the controls on the bottom panel of the unit. Your unit and your DMX controller require a approved DMX-512 110 Ohm Data cable for data input and data output (Figure 1). We recommend Accu-Cable DMX cables. If you are making your own cables, be sure to use standard 110-120 Ohm shielded cable (This cable may be purchased at almost all professional sound and lighting stores). Your cables should be made with a male and female XLR connector on either end of



Figure 1

the cable. Also remember that DMX cable must be daisy chained and cannot be split.

**Notice:** Be sure to follow figures two and three when making your own cables. Do not use the ground lug on the XLR connector. Do not connect the cable’s shield conductor to the ground lug or allow the shield conductor to come in contact with the XLR’s outer casing. Grounding the shield could cause a short circuit and erratic behavior.

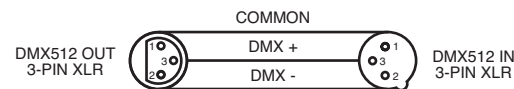

Figure 2

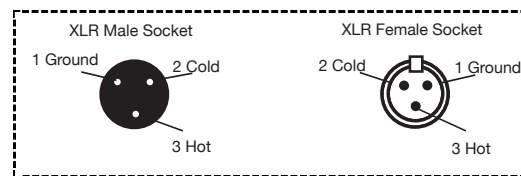

Figure 3

XLR Pin Configuration
Pin 1 = Ground
Pin 2 = Data Complement (negative)
Pin 3 = Data True (positive)

**Special Note: Line Termination.** When longer runs of cable are used, you may need to use a terminator on the last unit to avoid erratic behavior. A terminator is a 110-120 ohm 1/4 watt resistor which is connected between pins 2 and 3 of a male XLR connector (DATA + and DATA -). This unit is inserted in the female XLR connector of the last unit in your daisy chain to terminate the line. Using a cable terminator (ADJ part number Z-DMX/T) will decrease the possibilities of erratic behavior.



Termination reduces signal errors and avoids signal transmission problems and interference. It is always advisable to connect a DMX terminal, (Resistance 120 Ohm 1/4 W) between PIN 2 (DMX-) and PIN 3 (DMX +) of the last fixture.

Figure 4

**5-Pin XLR DMX Connectors.** Some manufactures use 5-pin DMX-512 data cables for DATA transmission in place of 3-pin. 5-pin DMX fixtures may be implemented in a 3-pin DMX line. When inserting standard 5-pin data cables in to a 3-pin line a cable adaptor must be used, these adaptors are readily available at most electric stores. The chart below details a proper cable conversion.

3-Pin XLR to 5-Pin XLR Conversion		
Conductor	3-Pin XLR Female (Out)	5-Pin XLR Male (In)
Ground/Shield	Pin 1	Pin 1
Data Compliment (- signal)	Pin 2	Pin 2
Data True (+ signal)	Pin 3	Pin 3
Not Used		Pin 4 - Do Not Use
Not Used		Pin 5 - Do Not Use

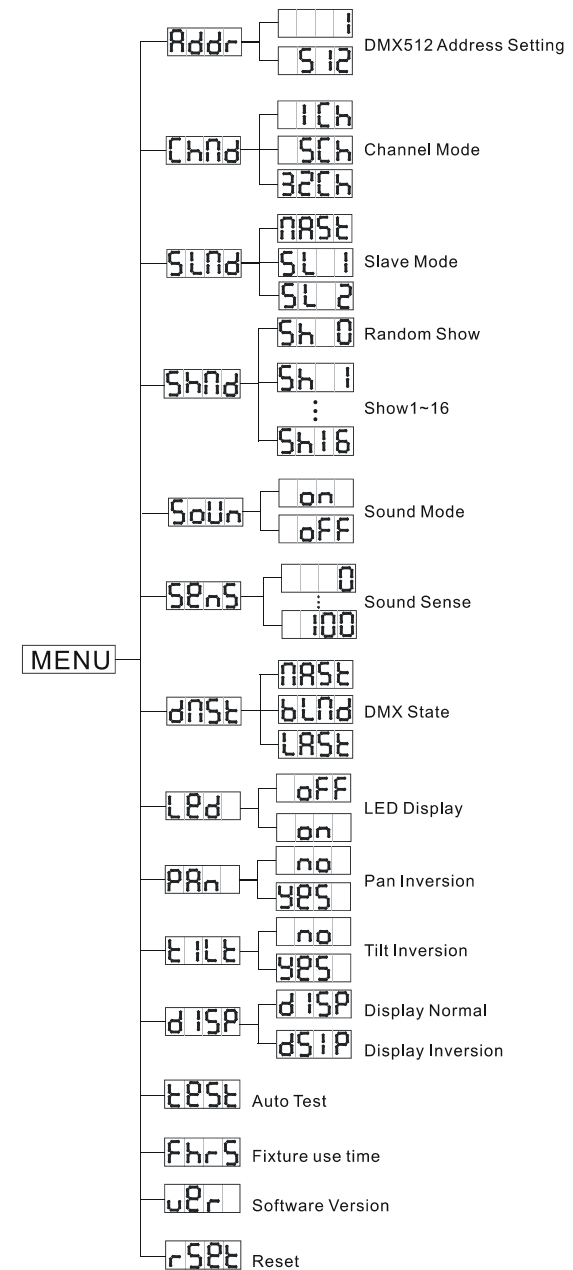

## **ADDR - DMX Address Setting.**

1. Press the either the MENU, UP, or DOWN buttons until “**ADDR**” is displayed, press ENTER.
2. The current address will now be displayed and flashing. Press the UP or DOWN buttons to find your desired address. Press ENTER to set your desired DMX address.

## **CHND - This will let select your desired DMX channel mode.**

1. Press the either the MENU button until “**CHND**” is displayed, press ENTER. Either “**1CH**”, “**5CH**” or “**32CH**” will be displayed
2. Press the UP or DOWN buttons to find your desired DMX mode and press ENTER to confirm and exit.

## **SLND - This will let you set unit as a master or slave in a master/slave configuration.**

1. Press the MENU button until “**SLND**” is displayed, press ENTER. Either “**MAST**”, “**SL 1**” or “**SL 2**” will be displayed.
2. Press the UP or DOWN buttons until your desired setting is displayed, press ENTER to confirm.

**NOTE:** In a Master/Slave configuration you can set one fixture to Master or Slave 1 (SL 1) and then set the next fixture to Slave 2 (SL 2), in doing this the fixtures will now have contrast movement to each other.

## **SHND: SH 0 - SH16 - Show modes 0-16 (Factory programs). Show mode can be run with sound activity or without. For show mode to run without sound activity turn sound activity off.**

1. Press the MENU button until “**SHND**” is displayed, press ENTER.
2. “**Sh X**” will now be displayed, “X” representing a number between

0-16. Programs 0-16 are factory programs, while Show 0 is random mode. Press the UP or DOWN buttons to find your desired show and press the ENTER, then press and hold the MENU button for at least 3 seconds to confirm.

## **SOUN - Sound Active mode. This mode will run in conjunction with show mode.**

1. Press the MENU button until “**SOUN**” is displayed, press ENTER.
2. The display will show either “**ON**” or “**OFF**”. Press the UP or DOWN buttons to select “**ON**” to activate sound active mode, or “**OFF**” to deactivate sound active mode.
3. Press the ENTER, and then press and hold the MENU button for at least 3 seconds to confirm.

## **SENS - Sound sensitivity control.**

1. Press the MENU button until “**SENS**” is displayed, press ENTER.
2. The display will show a number between 0-100. Press the UP or DOWN buttons to adjust the sound sensitivity. 0 being the least sensitive and 100 the most sensitive.
3. Press the ENTER button to confirm.

## **DNST - This mode can be used as a precaution mode, that in case the DMX signal is lost, the operating mode chosen in the setup is the running mode the fixture will go into when the DMX signal is lost. You can also set this as the operating mode you would like the unit to return to when power is applied.**

1. Press the MENU button until “**DNST**” is displayed, press ENTER.
2. Either “**MASL**”, “**BLND**”, or “**LAST**” will be displayed. Choose an operating mode you would like the unit to start up in when power is applied or the DMX signal is lost.

• **MASL** (Master Slave) - If the DMX signal is lost or power is applied, the unit will automatically go into Master Slave mode.

- **BLND** (Blackout) - If the DMX signal is lost or power is applied, the unit will automatically go into stand by mode.
  - **LAST** (Last State) - If the DMX signal is lost the fixture will stay in the last DMX set up. If power is applied and this mode is set, the unit will automatically go into the last DMX set up.
3. Press ENTER to confirm your desired set up.

### **LED - With this function you can have the LED display turn off after 10 seconds.**

1. Press the MENU button until “**LED**” is displayed, press ENTER.
2. The display will show either “**ON**” or “**OFF**”. Press the UP or DOWN buttons to select “**ON**” to keep the LED display on at all times, or “**OFF**” to switch to have the LED display switch off after 10 seconds.
3. Press the ENTER button to confirm.

### **PAN - Pan Inversion**

1. Tap the MENU button until “**PAN**” is displayed, press ENTER. Either Yes or No will be displayed.
2. To activate the Pan inversion tap the UP or DOWN buttons until YES is displayed, press ENTER to confirm. To deactivate Pan inversion, select NO and press Enter.

### **TILT - Tilt Inversion**

1. Tap the MENU button until “**TILT**” is displayed, press ENTER. Either YES or NO will be displayed.
2. To activate the Tilt inversion tap the UP or DOWN buttons until YES is displayed, press ENTER to confirm. To deactivate Tilt inversion, select NO and press Enter.

### **DISP - This will “flip” the LED display 180°.**

1. Press the MENU button until “**dISP**” is displayed, press ENTER.
2. Either “**dISP**” or “**dSIP**” will now be displayed. Press the UP or DOWN buttons to select one or the other.
3. Press the ENTER button to confirm.

### **TEST - This function will run a auto test program.**

1. Press the MENU button until “**TEST**” is displayed, press ENTER.
2. The fixture will now run a auto test.

### **FHRS - With this function you can display the running time of the fixture.**

1. Press the MENU button until “**FHRS**” is displayed, press ENTER.
2. The running time of the fixture will now be displayed. Press MENU to exit.

### **VER - With this function you can display the version software of the fixture.**

1. Press the MENU button until “**VER**” is displayed, press ENTER.
2. The software version will now be displayed. Press MENU to exit.

### **RSET - Use this function to reset the unit.**

1. Press the MENU button until “**RSET**” is displayed, press ENTER.
2. The fixture will now reset.

**Universal DMX Control:** This function allows you to use a universal DMX-512 controller to control the chases and patterns, dimmer and strobe. A DMX controller allows you to create unique programs tailored to your individual needs.

1. The Quad Scan Pro can be a 1, 5, or 32 DMX channel fixture. See pages 16-21 for detailed description of the DMX values and traits.
2. To control your fixture in DMX mode, follow the set-up procedures on pages 6-8 as well as the set-up specifications that are included with your DMX controller.
3. Use the controller's faders to control the various DMX fixture traits.
4. Follow the instructions on page 10 to set the DMX address.
5. For longer cable runs (more than a 100 feet) use a terminator on the last fixture.
6. For help operating in DMX mode consult the manual included with your DMX controller.

**Sound Active Mode:** This mode allows either single unit or several units linked together, to run to the beat of the music.

**Note: This mode runs in conjunction with show mode. You should select a show previous to activating sound active mode.**

1. Press the MENU button until "**SOUN**" is displayed, and press ENTER.
2. Press the UP or DOWN buttons so that "**ON**" is displayed, and press ENTER to confirm and then hold MENU for at least 2-3 seconds.
3. To adjust the sound sensitivity press the MENU button until "**SENS**" is displayed and press ENTER. Use the UP or DOWN buttons to adjust sensitivity.
4. The optional *UC3 Controller* (not included) may be used to control different functions including blackout. See page 16 for UC3 controls and functions.

**Show Mode:** In this mode you can select 1 of 16 shows to run. This mode can run as just an ordinary show, or with sound active mode.

1. Press the MENU button until "**SHND**" is displayed, and press ENTER.
2. Press the UP or DOWN buttons until you find your desired show, and press ENTER then press and hold MENU for 3 seconds to

confirm. See pages 10-11 for more info.

3. The optional *UC3 Controller* (not included) may be used to control different functions including blackout. See page 16 for UC3 controls and functions.

**Master-Slave Operation** This function will allow you to link up to 16 units together and operate without a controller. The units will be sound activated. In Master-Slave operation one unit will act as the controlling unit and the others will react to the controlling units programs. Any unit can act as a Master or as a Slave.

1. Using approved DMX data cables, daisy chain your units together via the XLR connector on the rear of the units. Remember the Male XLR connector is the input and the Female XLR connector is the output. The first unit in the chain (master) will use the female XLR connector only - The last unit in the chain will use the male XLR connector only. For longer cable runs we suggest a terminator at the last fixture.
2. On the Master unit find your desired show and set that show by pressing the ENTER button. After you have set your desired show, press the MENU button until "**SLND**" is displayed, and Press ENTER. Press the UP or DOWN buttons until "**MAST**" is displayed, and press ENTER to confirm.
3. On the slave units press the MENU button until "**SLND**" is displayed, and press ENTER. Press the UP or DOWN buttons until either "**SL 1**" or "**SL 2**" is displayed, choose your desired slave mode and press ENTER to confirm.
4. The slave units will now follow the Master unit.

**NOTE:** In a Master/Slave configuration you can set one fixture to Master or Slave 1 (SL 1) and then set the next fixture to Slave 2 (SL 2), in doing this the fixtures will now have contrast movement to each other.



**Quad Scan Pro 1 Channel Mode - DMX Traits**

Channel	Value	Function
1	0 - 7	SHOWS BLACKOUT
	8 - 22	SHOW 1
	23 - 37	SHOW 2
	38 - 52	SHOW 3
	53 - 67	SHOW 4
	68 - 82	SHOW 5
	83 - 97	SHOW 6
	98 - 112	SHOW 7
	113 - 127	SHOW 8
	128 - 142	SHOW 9
	143 - 157	SHOW 10
	158 - 172	SHOW 11
	173 - 187	SHOW 12
	188 - 202	SHOW 13
	203 - 217	SHOW 14
	218 - 232	SHOW 15
	233 - 247	SHOW 16
248 - 255	SOUND ACTIVE SHOWS 1-16	

**Quad Scan Pro UC3 Control**

Blackout	Blackout the unit	
Function	1. White LED Strobe 2. White LED Strobe by sound 3. Multicolor Strobe by sound	Select Show (Show 1-16)
Mode	Sound/Strobe (LED ON)	Show (LED Blinking)

**Quad Scan Pro 5 Channel Mode - DMX Traits**

Channel	Value	Function
1	0 - 7	PAN/TILT MOVEMENTS NO MOVEMENT
	8 - 22	MOVEMENT 1
	23 - 37	MOVEMENT 2
	38 - 52	MOVEMENT 3
	53 - 67	MOVEMENT 4
	68 - 82	MOVEMENT 5
	83 - 97	MOVEMENT 6
	98 - 112	MOVEMENT 7
	113 - 127	MOVEMENT 8
	128 - 142	MOVEMENT 9
	143 - 157	MOVEMENT 10
	158 - 172	MOVEMENT 11
	173 - 187	MOVEMENT 12
	188 - 202	MOVEMENT 13
	203 - 217	MOVEMENT 14
	218 - 232	MOVEMENT 15
	233 - 247	MOVEMENT 16
248 - 255	SOUND ACTIVE	
2	0 - 255	PAN/TILT SPEED MOVEMENT SLOW - FAST
3	0 - 255	MASTER DIMMER 0% - 100%
4	0 - 8	STROBING OPEN
	9 - 131	STROBING SLOW - FAST
	132 - 139	OPEN
	140 - 181	SLOW OPEN - FAST CLOSE
	182 - 189	OPEN
	190 - 231	FAST OPEN - SLOW CLOSE
	232 - 239	OPEN
	240 - 247	SOUND ACTIVE STROBING
	248 - 255	OPEN

Quad Scan Pro		5 Channel Mode - DMX Traits
Channel	Value	Function
5		STATIC COLOR SEQUENCE
	0 - 7	COLOR SEQUENCE 1
	8 - 15	COLOR SEQUENCE 2
	16 - 23	COLOR SEQUENCE 3
	24 - 31	COLOR SEQUENCE 4
	32 - 39	COLOR SEQUENCE 5
	40 - 47	COLOR SEQUENCE 6
	48 - 55	COLOR SEQUENCE 7
	56 - 63	COLOR SEQUENCE 8
	64 - 71	COLOR SEQUENCE 9
	72 - 79	COLOR SEQUENCE 10
	80 - 87	COLOR SEQUENCE 11
	88 - 95	COLOR SEQUENCE 12
	96 - 103	COLOR SEQUENCE 13
	104 - 111	COLOR SEQUENCE 14
	112 - 119	COLOR SEQUENCE 15
	120 - 127	COLOR SEQUENCE 16
	128 - 135	COLOR SEQUENCE 17
	136 - 143	COLOR SEQUENCE 18
	144 - 151	COLOR SEQUENCE 19
	152 - 159	COLOR SEQUENCE 20
	160 - 167	COLOR SEQUENCE 21
	168 - 175	COLOR SEQUENCE 22
	176 - 183	COLOR SEQUENCE 23
	184 - 191	COLOR SEQUENCE 24
	192 - 199	COLOR SEQUENCE 25
	200 - 207	COLOR SEQUENCE 26
	208 - 215	COLOR SEQUENCE 27
	216 - 223	COLOR SEQUENCE 28
	224 - 231	COLOR SEQUENCE 29
	232 - 239	COLOR SEQUENCE 30
	240 - 247	COLOR SEQUENCE 31
248 - 255	COLOR SEQUENCE 32	

Quad Scan Pro		32 Channel Mode - DMX Traits
Channel	Value	Function
1	0 - 255	MIRROR 1 PAN
2	0 - 255	MIRROR 1 TILT
3	0 - 255	RED (MIRROR 1)
		0% - 100%
4	0 - 255	GREEN (MIRROR 1)
		0% - 100%
5	0 - 255	BLUE (MIRROR 1)
		0% - 100%
6	0 - 255	WHITE (MIRROR 1)
		0% - 100%
7	0 - 255	MASTER DIMMER (MIRROR 1)
		0% - 100%
8	0 - 8	STROBING (MIRROR 1)
		OPEN
		STROBING SLOW - FAST
		OPEN
		FAST CLOSE - SLOW OPEN
		OPEN
		SLOW CLOSE - FAST OPEN
		OPEN
9	0 - 255	SOUND ACTIVE STROBING
		OPEN
		MIRROR 2 PAN
		MIRROR 2 TILT
11	0 - 255	RED (MIRROR 2)
		0% - 100%
12	0 - 255	GREEN (MIRROR 2)
		0% - 100%
13	0 - 255	BLUE (MIRROR 2)
		0% - 100%
14	0 - 255	WHITE (MIRROR 2)
		0% - 100%
15	0 - 255	MASTER DIMMER (MIRROR 2)
		0% - 100%

Quad Scan Pro		32 Channel Mode - DMX Traits
Channel	Value	Function
16	0 - 8	STROBING (MIRROR 2) OPEN
	9 - 131	STROBING SLOW - FAST
	132 - 139	OPEN
	140 - 181	FAST CLOSE - SLOW OPEN
	182 - 189	OPEN
	190 - 231	SLOW CLOSE - FAST OPEN
	232 - 239	OPEN
	240 - 247	SOUND ACTIVE STROBING
	248 - 255	OPEN
17	0 - 255	MIRROR 3 PAN
18	0 - 255	MIRROR 3 TILT
19	0 - 255	RED (MIRROR 3) 0% - 100%
	0 - 255	0% - 100%
20	0 - 255	GREEN (MIRROR 3) 0% - 100%
	0 - 255	0% - 100%
21	0 - 255	BLUE (MIRROR 3) 0% - 100%
	0 - 255	0% - 100%
22	0 - 255	WHITE (MIRROR 3) 0% - 100%
	0 - 255	0% - 100%
23 24	0 - 255	MASTER DIMMER (MIRROR 3) 0% - 100%
	0 - 8	STROBING (MIRROR 3) OPEN
	9 - 131	STROBING SLOW - FAST
	132 - 139	OPEN
	140 - 181	FAST CLOSE - SLOW OPEN
	182 - 189	OPEN
	190 - 231	SLOW CLOSE - FAST OPEN
	232 - 239	OPEN
	240 - 247	SOUND ACTIVE STROBING
248 - 255	OPEN	
25	0 - 255	MIRROR 4 PAN

Quad Scan Pro		32 Channel Mode - DMX Traits
Channel	Value	Function
26	0 - 255	MIRROR 4 TILT
27	0 - 255	RED (MIRROR 4) 0% - 100%
	0 - 255	0% - 100%
28	0 - 255	GREEN (MIRROR 4) 0% - 100%
	0 - 255	0% - 100%
29	0 - 255	BLUE (MIRROR 4) 0% - 100%
	0 - 255	0% - 100%
30	0 - 255	WHITE (MIRROR 4) 0% - 100%
	0 - 255	0% - 100%
31 32	0 - 255	MASTER DIMMER (MIRROR 4) 0% - 100%
	0 - 8	STROBING (MIRROR 4) OPEN
	9 - 131	STROBING SLOW - FAST
	132 - 139	OPEN
	140 - 181	FAST CLOSE - SLOW OPEN
	182 - 189	OPEN
	190 - 231	SLOW CLOSE - FAST OPEN
	232 - 239	OPEN
	240 - 247	SOUND ACTIVE STROBING
248 - 255	OPEN	

## Quad Scan Pro

## Gobo Replacement

The Quad Scan Pro comes with 4 replaceable gobos. This gobos can be interchanged at any time and allows you to customize your system.

To replace gobo;

1. Select the gobo you would like to replace and unscrew the thumb screw that is holding the gobo housing in place. Note: The thumb screw cannot be removed.
2. Remove the gobo housing.
3. Once the gobo housing has been removed, remove the retaining ring that holds the gobo in. This can easily be done using needle nose pliers.
4. Remove and replace the gobo with your desired replacement. Reinsert the retainer ring, and make sure the ring rests firmly against the gobo.
5. Slide the gobo housing back into place, and secure the housing by tightening the thumb screw.

## Quad Scan Pro

## Power Cord Daisy Chain

***With this feature you can connect the fixtures to one another using the IEC input and output sockets. The quantity that can be connected is 4 fixtures maximum. After 4 fixtures you will need to use a new power outlet. They must be the same fixtures. DO NOT mix fixtures.***

## Quad Scan Pro

## Fuse Replacement

Disconnect the unit from its power source. Remove the power cord from the unit. Once the cord has been removed, you will find that the fuse holder is located inside the power socket. Insert a flat-head screw driver into the power socket and gently pry out the fuse holder. Remove the bad fuse and replace with a new one. The fuse holder also has a holder for a spare fuse.

## Quad Scan Pro

## Cleaning

**Fixture Cleaning:** Due to fog residue, smoke, and dust cleaning the internal and external optical lenses and mirror should be carried out periodically to optimize light output. Cleaning frequency depends on the environment in which the fixture operates (I.e. smoke, fog residue, dust, dew). In heavy club use we recommend cleaning on a monthly basis. Periodic cleaning will ensure longevity, and crisp output.

1. Use normal glass cleaner and a soft cloth to wipe down the outside casing.
2. Use a brush to wipe down the cooling vents and fan grill.
3. Clean the external optics and mirror with glass cleaner and a soft cloth every 20 days.
4. Clean the internal optics with glass cleaner and a soft cloth every 30-60 days.
5. Always be sure to dry all parts completely before plugging the unit back in.

## Quad Scan Pro

## Trouble Shooting

**Trouble Shooting:** Listed below are a few common problems that you may encounter, with solutions.

### ***No light output from the unit;***

1. Be sure the external fuse has not blown. The fuse is located on the rear panel of the unit.
2. Be sure the fuse holder is completely and properly seated.

### ***Unit does not respond to sound;***

1. Low frequencies (bass) should cause the unit to react to sound. Tapping on the microphone, quiet or high pitched sounds may not activate the unit.

## MANUFACTURER'S LIMITED WARRANTY

- A. ADJ Products, LLC hereby warrants, to the original purchaser, ADJ Products, LLC products to be free of manufacturing defects in material and workmanship for a prescribed period from the date of purchase (see specific warranty period on reverse). This warranty shall be valid only if the product is purchased within the United States of America, including possessions and territories. It is the owner's responsibility to establish the date and place of purchase by acceptable evidence, at the time service is sought.
- B. **For warranty service you must obtain a Return Authorization number (RA#) before sending back the product—please contact ADJ Products, LLC Service Department at 800-322-6337.** Send the product only to the ADJ Products, LLC factory. All shipping charges must be pre-paid. If the requested repairs or service (including parts replacement) are within the terms of this warranty, ADJ Products, LLC will pay return shipping charges only to a designated point within the United States. If the entire instrument is sent, it must be shipped in its original package. No accessories should be shipped with the product. If any accessories are shipped with the product, ADJ Products, LLC shall have no liability whatsoever for loss of or damage to any such accessories, nor for the safe return thereof.
- C. This warranty is void if the serial number has been altered or removed; if the product is modified in any manner which ADJ Products, LLC concludes, after inspection, affects the reliability of the product; if the product has been repaired or serviced by anyone other than the ADJ Products, LLC factory unless prior written authorization was issued to purchaser by ADJ Products, LLC; if the product is damaged because not properly maintained as set forth in the instruction manual.
- D. This is not a service contract, and this warranty does not include maintenance, cleaning or periodic check up. During the period specified above, ADJ Products, LLC will replace defective parts at its expense with new or refurbished parts, and will absorb all expenses for warranty service and repair labor by reason of defects in material or workmanship. The sole responsibility of ADJ Products, LLC under this warranty shall be limited to the repair of the product, or replacement thereof, including parts, at the sole discretion of ADJ Products, LLC. All products covered by this warranty were manufactured after August 15, 2012, and bear indentifying marks to that effect.
- E. ADJ Products, LLC reserves the right to make changes in design and/or improvements upon its products without any obligation to include these changes in any products theretofore manufactured.

No warranty, whether expressed or implied, is given or made with respect to any accessory supplied with products described above. Except to the extent prohibited by applicable law, all implied warranties made by ADJ Products, LLC in connection with this product, including warranties of merchantability or fitness, are limited in duration to the warranty period set forth above. And no warranties, whether expressed or implied, including warranties of merchantability or fitness, shall apply to this product after said period has expired. The consumer's and/or Dealer's sole remedy shall be such repair or replacement as is expressly provided above; and under no circumstances shall ADJ Products, LLC be liable for any loss or damage, direct or consequential, arising out of the use of, or inability to use, this product.

This warranty is the only written warranty applicable to ADJ Products, LLC Products and supersedes all prior warranties and written descriptions of warranty terms and conditions heretofore published.

## MANUFACTURER'S LIMITED WARRANTY PERIODS:

- **Lighting Products = 1-year (365 days) Limited Warranty** (Such as: Special Effect Lighting, Intelligent Lighting, UV lighting, Strobes, Fog Machines, Bubble Machines, Mirror Balls, Par Cans, Trussing, Lighting Stands etc. excluding LED and lamps)
- **Laser Products = 90-Day Limited Warranty**
- **L.E.D. Products = 3-year (1095 days) Limited Warranty** (excluding motors, PCB boards, and power supplies, which have a 1-year (365 day Limited Warranty) and batteries which have a 180 day limited warranty). Only the L.E.D.s carry a 3-year warranty

<b>Model:</b>	<b>Quad Scan Pro</b>
<b>Voltage:</b>	100~240V 50Hz/60Hz
<b>LEDs:</b>	4 X 10 Watt 4-in-1 RGBW LEDs
<b>Power Cord Daisy Chain:</b>	4 Fixtures Max.
<b>Power Consumption:</b>	88W
<b>Dimensions:</b>	17.25"(L) x 14.25"(W) x 5.25"(H) 438mm x 356mm x 133mm
<b>Colors:</b>	RGBW
<b>Gobos:</b>	4
<b>Gobo Size:</b>	20.5mm 12mm (Viewable)
<b>Weight:</b>	17 Lbs. / 7.5 kgs.
<b>Fuse:</b>	7 Amp
<b>Duty Cycle:</b>	None
<b>DMX:</b>	1, 5, & 32 DMX Channel Modes
<b>Sound Active:</b>	Yes
<b>Working Position:</b>	Any Safe, Secure Position
<b>Warranty:</b>	3 Year (1095 days)

**Auto Sensing Voltage:** This fixture contains a automatic voltage switch, which will auto sense the voltage when it is plugged into the power source.

**Please Note:** Specifications and improvements in the design of this unit and this manual are subject to change without any prior written notice.

ADJ Products, LLC  
6122 S. Eastern Ave. Los Angeles, CA 90040 USA  
Tel: 323-582-2650 / Fax: 323-725-6100  
Web: [www.adj.com](http://www.adj.com) / E-mail: [info@adj.com](mailto:info@adj.com)

A.D.J. Supply Europe B.V.  
Junostraat 2  
6468 EW Kerkrade  
Netherlands

Follow Us On:



[facebook.com/americandj](https://facebook.com/americandj)  
[twitter.com/americandj](https://twitter.com/americandj)  
[youtube.com/adjlighting](https://youtube.com/adjlighting)

[service@adj.eu](mailto:service@adj.eu) / [www.adj.eu](http://www.adj.eu)  
Tel: +31 45 546 85 00 / Fax: +31 45 546 85 99